

Smart Series[®]

CIM-10-G

CIM-10-GS

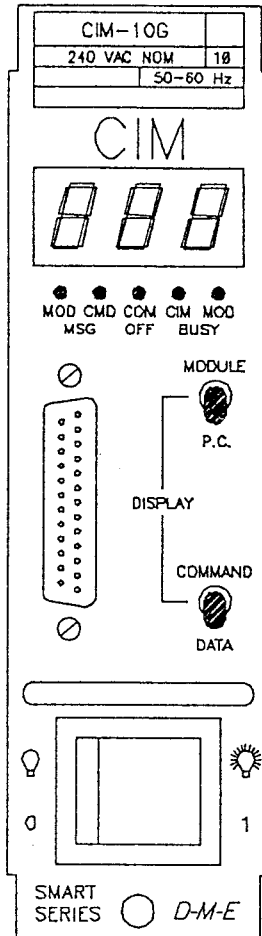

Microprocessor-Based Computer Interface Module

User's Manual

D-M-E Company

D-M-E Standard Smart Series[®] Microprocessor-Based Computer Interface Module

CIM-10-GS (For SPI 3.01)

CIM-10-G (For Personal Computers)

GENERAL DESCRIPTION

The CIM Computer Interface Module represents an impressive breakthrough in automated process management and information gathering. Used in conjunction with D-M-E[®] CSS[®] modules and main frames with communications capability, the CIM module was developed to connect a D-M-E Temperature Control System to a computer or molding machine. The CIM module provides a method to collect vital information that was once difficult to obtain and analyze. Equally important is the CIM's ability to control alarms, standby heat settings, setpoint and process temperatures directly from a computer. This all adds up to greater control and accuracy as management can virtually control all temperature related operations from one remote location computer. The CIM module and the CSS[®] module are part of a temperature control system specifically designed for runnerless injection molding of plastic parts.

MONITORS AND TRACKS OPERATING CONDITIONS

In conjunction with all the above functions, the CIM interface module also permits selection or monitoring of the following conditions: Over and under temperature; open, shorted or reversed thermocouple; Smart Start[®] Mode; manual mode; power to load and ground fault. Printed reports of all these conditions can be generated automatically with the supplied computer software for any time interval needed. A standby temperature control setting is available for preventing overnight and weekend condensation in the heaters. The standby heat setting can be set up so that the temperature stays low all night and then automatically switches to the setpoint temperatures entered on the modules for a designated time before the shift begins.

FEATURES

CIM-10-GS

- SPI 3.01 Compatible - will connect and operate from machine control consoles equipped with SPI 3.01 Standard Communications Protocol (DEV. ID 26).

CIM-10-G

- D-M-E CIM 5-1/4" diskette included for IBM[®]-PC[™] computers. 3-1/2" diskettes are available on request.
- Industry Standard Interfaces: EIA232, EIA485 multidrop, EIA422.

- Simple to use—requires no special training.
- 63 zone communications capability (with D-M-E software).
- Compatible with both Smart Series[®] and G-Series[®] communications style (MFCP) Main Frames.*
*For use with CSS[®] modules only. Not compatible with previous CMP or present SSM or DSS modules.

NOTE: Non-communications style Main Frames (MFP) must be upgraded to communications style (MFCP) with and easy-to-install Communications Interface Kit (CIK) available from D-M-E. Contact D-M-E for details.

COMPATIBLE INTERFACES

(jumper select on module)

RS232(EIA232)DUPLEX.....50ft.max.

RS485 (EIA485) DIFFERENTIAL.....4000ft. max. multidrop

RS422(EIA422)DIFFERENTIAL.....4000ft.max.

NOTE: Cables for RS232 interface are available from D-M-E. See page Q-39 of D-M-E catalog.

INSTALLATION

CIM module is connected to a computer or molding machine. The CIM module simply slides into any unused zone position in the mainframe to provide communications to all zones. The system is immediately operational after the computer is plugged into the CIM Module. The CIM requires a computer with a serial EIA232, EIA485, or EIA422 port and D-M-E[®] supplied software or molding machine running SPI compatible software. See software specifications below for additional details.

SOFTWARE

User friendly software, with simple menus for operating mode selection, is supplied with each CIM module. It is supplied on a 5-1/4 diskette for use with an IBM[®] PC[™]* or compatibles.

*Registered trademark and trademark of International Business Machines, Inc.

D-M-E® CIM SOFTWARE SPECIFICATIONS

Maximum Number of Zones: 63

Maximum Number of Machines: 8, using one CIM module for each mainframe group, connected to one cpu.

Baud Rate: 9600. Other baud rates under development.

CPU and CIM Serial Port Used: COM2, IRQ3 or COM1, IRQ4 selectable.

CIM-10-GS

Molding Machine Requirements: SPI 3.01 runnerless temp control software compatible. Contact your molding machine manufactures.

CIM-10-G

Computer Requirements: 640K bytes of RAM, MS or PC DOS based system.

The host molding machine or computer must be outfitted with on EIA 232, 422 or 485 communications.

FRONT PANEL CONTROLS AND INDICATORS: (See Figure 1)

1. **DIGITAL LED DISPLAY:** Multi-Function Display Indicates the Transmitted Data or Commands.
2. **COMMUNICATIONS CONNECTOR:** DB-25 style input/output connector. A duplicate of this connector is included at rear of module for those who prefer to route the computer interface wirings internally.
3. **HANDLE:** Assists in insertion or removal of module from main frame.
4. **POWER ON/OFF SWITCH:** Controls AC power to the module.
5. **PUSH-PULL FASTENER:** Quickly locks modules into main frame. No tools required.
6. **IDENTIFICATION LABEL:** Provides module catalog number and power ratings for quick reference.

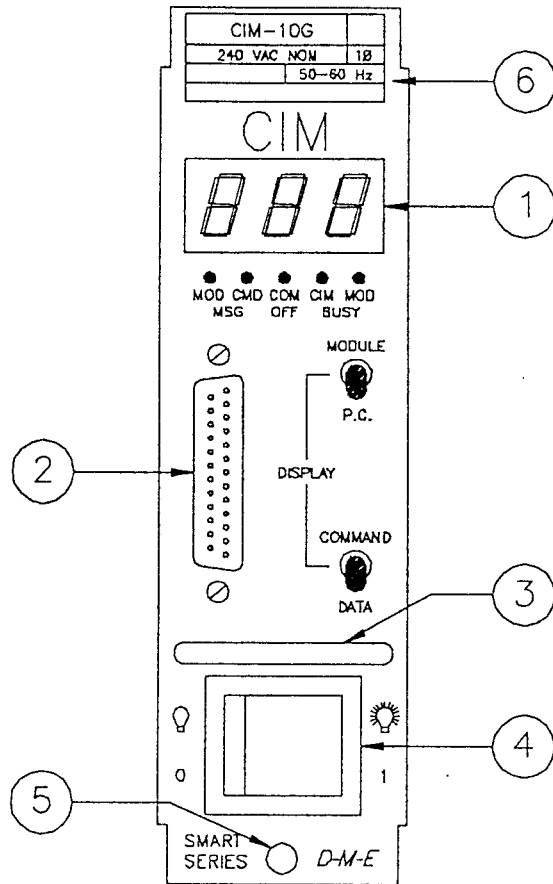

Figure 1 - CIM-10-G Module

CABLES

10 and 50 foot cables for RS232 interface are available as standard. Cables for RS485 and RS422 available on special order.

CIM-10-G

SCREENS (See Figures 2 & 3)

Shown on page 4 and 5 are examples of selected screens and CIM program main menu (page 5). These screens permit the monitoring of various heater zone conditions, along with the set-ups and termination of specific control functions. Printouts of this information can be generated for any desired time interval. Remote control of each zone can be set-up and run sequentially over designated time periods. The last 8 alarm conditions encountered by the system can be viewed on "problem alert" screen L.

Screen A shows user heater information for 8 zones at a time (for each machine). This information consists of heater conditions including all alarms. All information is continually updated to show changes.

Screen C shows the user 24 zones of information at one time. Zone name set point and degrees of deviation (from the setpoint) are the categories of information displayed.

Screen D shows the user 24 zones of information at one time. Zone name, percent power and actual temperature are displayed.

Screen E displays information that a user may select to generate on a printer. The "A" Screen can be set up to print over various time intervals.

Screen F allows the user to control all zone setpoints independently. The setup may be saved or run at any time. Program number, machine number, mold description, setpoint temperature and zone name can be entered.

CIM-10-G ONLY

SCREEN A

A.....MONITOR ALL ZONES - HEATER CONDITIONS PAGE: 01

MACHINE NUMBER	1	HOLD DESCRIPTION	TEST HOLD #	DATE	01/01/91					
ZONE	ZONE	SET-	ACTUAL	SMART	HEATER	ALARM	OF1	TC	TC	COMM
#	NAME	POINT	TEMP	START	ON	BREAK	REV	REV	ERR	ERR
01	CAV1	313	REX	E44	PWR	LDV				
02	CAV2	314	REX	E84	PWR	LDV				
03	CAV3	315	REX	E28	PWR	LDV				
04	CAV4	316	REX	E91	PWR	LDV				
05	CAV5	317	REX	E94	PWR	LDV				
06	B1ST	322	REX	E93	PWR	LDV				
07	SEC	321	REX	E85	PWR	LDV				
08	N/A									

H-MENU F-FORWARD B-BACKWARD H-HELP

SCREEN C

C.....MONITOR ALL MACHINES - TEMPERATURE DEVIATION FROM SETPOINT

Machine No. 1	Machine No. 2	Machine No. 3			
Z	Z	Z			
#	#	#			
NAME	NAME	NAME			
POINT	POINT	POINT			
DEVI.	DEVI.	DEVI.			
01	CAV1	E13	-E		
02	CAV2	E14	-1		
03	CAV3	E15	-2		
04	CAV4	E16	-E		
05	CAV5	E17	-1		
06	B1ST	E22	E		
07	SEC	E21	-E		
08	N/A				

H-MENU F-FORWARD B-BACKWARD H-HELP

SCREEN B

B.....MONITOR ALL MACHINES - PERCENT POWER LEVELS

Machine No. 1	Machine No. 2	Machine No. 3			
Z	Z	Z			
#	#	#			
NAME	NAME	NAME			
POWER	POWER	POWER			
TEMP.	TEMP.	TEMP.			
01	CAV1	722	E13		
02	CAV2	482	E14		
03	CAV3	812	E15		
04	CAV4	682	E16		
05	CAV5	562	E17		
06	B1ST	682	E22		
07	SEC	572	E21		
08	N/A				

H-MENU F-FORWARD B-BACKWARD H-HELP

SCREEN D

D.....PRINT REPORTS FOR ALL ZONES

THIS FUNCTION WILL ALLOW THE USER TO PRINT REPORTS ON HEATER CONDITIONS FOR ALL ZONES. YOU MAY ASK FOR A SINGLE PRINTOUT BY ENTERING 00.00 IN THE 'TIME INTERVAL' BOX.

MACHINE NUMBER 1

TIME INTERVAL 01.00 HRS:MIN
00:00:00

H-MENU E-EXIT B-RUN T-TERMINATE H-HELP

SCREEN F

F.....ENTER FOR EACH ZONE - A SETPOINT DATE 01/01/91

SETUP NUMBER	005	MACHINE NUMBER	1	HOLD DESCRIPTION	TEST HOLD #	02
ZONE	SETPOINT	ZONE	SETPOINT	ZONE	SETPOINT	ZONE
#	NAME	#	NAME	#	NAME	#
01	313	CAV1	09	500	CAV6	
02	314	CAV2	10	500	CAV7	
03	315	CAV3	11	500	CAV8	
04	316	CAV4	12	500	CAV9	
05	317	CAV5	13	500	CAV11	
06	322	B1ST	14	500	CAV11	
07	321	SEC	15	500	CAV12	
08	321	SEC	16	500	CAV13	

H-MENU E-EDIT F-FORWARD B-BACKWARD S-SAVE B-RUN H-HELP

SCREEN E

E.....ENTER FOR EACH MACHINE - A PROGRAMMED SETUP

THIS FUNCTION WILL ALLOW THE USER TO RUN VARIOUS SAVED SETUP PROGRAM NUMBERS OVER VARIOUS DURATIONS. (99 HRS:MIN + 1MIN:00)

MACHINE NUMBER 1

PROGRAM NUMBER	SEQUENCE 1	SEQUENCE 2	SEQUENCE 3
	111	123	555
TIME DURATION	04.00	02.00	18.00
	49:52:02		HRS:MIN

H-MENU E-EDIT T-TERMINATE B-RUN H-HELP

SCREEN I

I.....ENTER FOR ALL ZONES - A STANDBY TEMPERATURE SETPOINT

THIS FUNCTION WILL SET A SINGLE SETPOINT TEMPERATURE FOR ALL ZONES. ALL ZONES MUST HAVE A COMMUNICATIONS TYPE CONTROL MODULE ACTIVE. THIS SETPOINT CAN BE HELD OVER ANY DURATION. ALL ACTIVE ZONES WILL RETURN TO INDIVIDUAL FACEPLATE SETPOINTS UPON THE EXPIRATION OF THE TIME INTERVAL.

MACHINE NUMBER 1

STANDBY SETPOINT TEMPERATURE 204

TIME DURATION COUNTDOWN 16:01 HRS:MIN
00:00:00

H-MENU E-EXIT T-TERMINATE B-RUN H-HELP

SCREEN L

L.....PROBLEM ALERT PAGE: 01

MACHINE NUMBER	1	HOLD DESCRIPTION	TEST HOLD #	DATE	01/01/91					
ZONE	ZONE	SET-	ACTUAL	SMART	HEATER	ALARM	OF1	TC	TC	COMM
#	NAME	POINT	TEMP	START	ON	BREAK	REV	REV	ERR	ERR
02	CAV2									ERR
03	CAV3	308	E29	PWR	LDV					
05	CAV5	E4	68	HGR						
07	SEC	314	E66	PWR	LDV					

H-MENU F-FORWARD H-HELP

Figure 2. Screens A,C,D,E,F,G,I,L

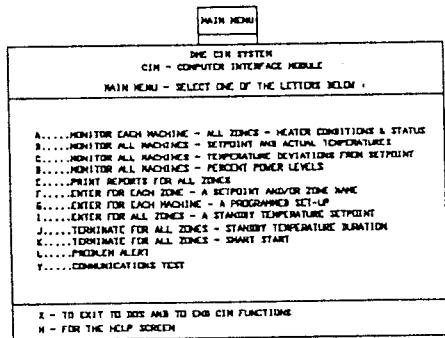

Figure 3. Main Menu (CIM-10-G ONLY)

Screen G allows the user to sequence multiple allowing for automatic setpoint changes at predetermined times.

Screen I allows the user to set up single standby setpoint temperature for all zones on any machine over any time period.

Screen L allows the user to view the screen "A" information for the last 8 alarm conditions that occurred.

ELECTRICAL POWER SPECIFICATIONS:

Input Voltage: 240/120 VAC +10% -20%, 240 VAC Standard, 120VAC Available

Frequency: 50/60 Hz

DC Power Supplies: Internally generated, regulated and compensated

Module power usage: Less than 5 watts

Dimensions:
2"W x 7"H x 7 1/2"D (5.08 x 17.78 x 19.05cm)

NOTE: Modules are compatible with main frames wired with communications kit

ELECTRICAL CONNECTIONS

When connecting the CIM module to a personal computer or other input device the following communications protocol must be followed: The CIM module is supplied with a twenty-five pin DB-25 D-subminiature connector mounted to the faceplate and another mounted to the backside of the heat sink near the rear of the module. The two connectors are wired the same so that either one may be used. Mating connectors, male DB-25-P plugs, can be purchased at any electronics supply or computer store. The wire type required is as follows: 24 AWG shielded twisted-pair cable with a shunt capacitance of less than 52.5 pF/M. A standard "off-the-shelf" cable that meets this specification is the Belden part number 9730. Custom cables can be ordered as specials through D-M-E.

NOTE: A rotary switch has been provided on the component side of the circuit board near the rear of the module. This switch, used as the "machine selector", must remain in the "1" position unless you are using RS-485 wiring for multiple machines. In this case, the switch must be set to indicate "1" for the first machine, "2" for the second machine,upto "8"

for the eighth machine. This is used to identify the different mainframe systems to the personal computer.

WIRING THE CIM TO A PERSONAL COMPUTER

Typical Wiring RS-232 (EIA-232) 50 feet or less. (Not advised for noisy environments.)

	Pin No.		Pin No.	
CIM	2	—RECEIVE—	3	Personal
Module	3	—TRANSMIT—	2	Computer
Connector	7	—COMMON—	7	Connector

(Typical)

The above can be accomplished with a standard pin-to-pin serial communications connector and a "null modem" adaptor which switches pins 2 and 3.

(SPI3.01 Interface)

Typical Wiring RS-485 (EIA-485) 1200 meters (4000 feet) or less.

See Figures 7 & 8.

This interconnection scheme must be used for applications of more than one machine (CIM module) per computer or molding machine. Wiring must be connected in a daisy-chain configuration.

(Daisy chain CIM units if more than one CIM is used. See figure 5.)

NOTE: The RS-485 standard should be wired in a daisy-chain arrangement with the computer at one end of the chain. A termination resistor of 120 ohms has been soldered on a connector installed on the rear of the heat sink plate for each CIM module. RS-485 requires that a termination resistor be installed on the last unit of the daisy-chain configuration. Therefore, the termination resistor plug should be removed from all units located between the computer and the last CIM module. Also, RS-485 requires that a 120 ohm termination resistor be installed at the computer end of the daisy-chain cable connector.

Typical Wiring RS-422 (EIA-422) 1200 meters (4000 feet) or less.

	Pin No.		Pin No.	
CIM	14	—RECV. (+)—	2	Personal
Module	15	—RECV. (-)—	7	Computer
Connector	16	—XMIT (-)—	8	Connector
	17	—XMIT (+)—	4	(Typical)
	7	—COMMON—	3	

Some minor printed circuit board modifications to the CIM module must be made to adapt to the RS-422 standard.

OTHER THINGS YOU NEED TO KNOW

We operate the CIM module at 9600 BAUD, no parity, 8 data bits. Any further information required regarding the

method of data transmission can be obtained through the D-M-E Engineering Department.

TROUBLESHOOTING CABLES

Cables must be wired correctly to match the communications configuration in order to function properly. Each connection must be made with the highest quality termination available. If you are using a crimp tool and crimp tight connectors, the crimp must be as specified by the connector manufacturer. Also, if solder POT (cup) connectors are used, solder joints must be checked to ensure that they are not cold soldered joints, or have frayed wires. All cables should be checked with an ohm meter to ensure that all terminations have a resistance of less than 2 ohms. Also, check for crossed (short circuited) wires.

CONTROLLER MODULES

Controller modules can cause problems with communications and yet still work well at controlling temperature. This is due to a separate set of electronic components used on the controller for communications. Sometimes a controller can cause communications problems with neighboring modules. This problem can be best detected by testing communications with only using one module inserted into the main frame along with a CIM module. If the problem can be narrowed down to a particular module, that module will need to be repaired. However, if all modules exhibit the same problem, it is probably not a controller problem.

COMPUTER HARDWARE

Computer hardware or circuit boards used inside a computer can also cause problems with communications. These boards must be installed and used as recommended by the manufacturer. Check to see if the manufacturer's connector wiring pin out is the same as our sample diagrams. If not, change the cable wiring (at the personal computer end only) to match. If problems develop after additional boards have been installed, there is probably a conflict between those boards and the communications boards used for this application. Please check your technical manuals for further information on conflicts with serial ports.

COMPUTER SOFTWARE

Computer software can be a cause of many problems, especially when the software supports a new application in which it changes system configurations. These problems are sometimes difficult to detect and might require additional help from the software supplier.

MAIN FRAME ENCLOSURES

Most common of all problems with the main frame enclosures is that the modules are not inserted all the way into the slot. This is critical due to the number of connections made at the communications strip which is located in the rear connector panel of the main frame. Many times the push latch has been damaged and one of its segments has been bent against the faceplate. This restricts the module from being inserted fully into the main frame. It is best to trim this segment off. This will allow the latch to work correctly.

Another common problem is an unaddressed or misaddressed communications strip in the mainframe, or no communications strip installed at all. Refer to the D-M-E Technical Manual for the Smart Series Temperature Controls System, to determine if the communications strip is present and addressed properly.

CIM MODULE

Although it is rare, the CIM may be causing a problem with communications. Typically, this is due to setup jumpers not installed correctly. (See figure 4.)

HOW TO USE THE D-M-E[®] CIM SOFTWARE PROGRAM (CIM-10-G)

A CIM program is supplied with the CIM module. This program allows the user to communicate with up to eight molding machines, sixty-three zones on each molding machine. This program is supplied on one 5-1/4 inch diskette. The program will run on any MS-DOS™ or PC-DOS™ based systems with 640K of RAM installed. The diskette is formatted to 360K bytes. To run the program, type: *Z1* or *Z1COMX*, where X is the chosen communications port, (1 or 2 are the allowable choices), and hit RETURN or ENTER. When the screen comes up it will ask for a password. The initial password has been set to "DME." The password can be changed using the program entitled password. To do this, type in: *PASSWORD* and hit the RETURN or ENTER key.

After the password has been accepted, the program will go through a check of which modules are active. Therefore, the CIM and temperature control modules must be powered-up before the CIM program is initiated. Any modules or main frames powered-up after the CIM program has been started will not be seen by the CIM program until they are added by using Menu Selection *N.* The rest of the program can be operated by following the instructional prompts within the program.

Any further questions regarding this or any other portion of the CIM implementation, should be referred to the D-M-E Electronics Engineering Department.

RETURN POLICY:

The D-M-E[®] CIM-10-G & CIM-10-GS modules are warranted for 1 year parts and labor, excluding fuses.

Contact D-M-E Customer Service for return authorization for repairs or warranties. Replacement parts are also available through the Customer Service Department.

D-M-E Customer Service

In U.S., West Coast:	1-213-263-9261
Elsewhere in U.S.:	1-800-626-6653
In Canada:	1-416-677-6370

SERVICE CENTER U.S.A.

D-M-E WORLD HEADQUARTERS
29111 STEPHENSON HIGHWAY
MADISON HEIGHTS, MICHIGAN 48071
TELEFAX(313)398-6174

REPLACEMENT PARTS LIST

To meet warranty requirements, use only DME[®] parts.

S1, Power Rocker Switch, 16 Amp, 250 VAC RPM0008

G-Series[®], Smart Series[®], Smart Start[®], and D-M-E[®] are all registered trademarks of D-M-E Company.

MS-DOS - Trademark of Microsoft Corporation

PC-DOS - Trademark of the IBM Corporation

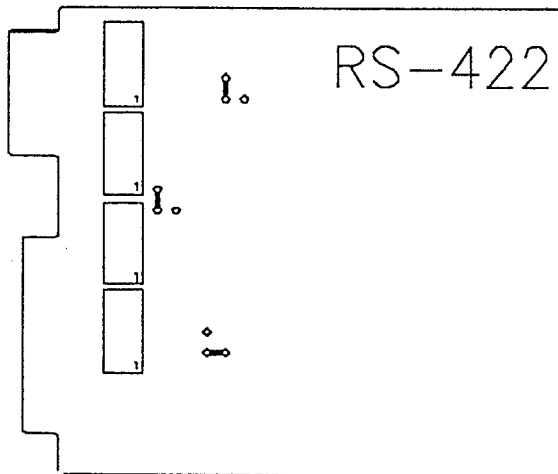
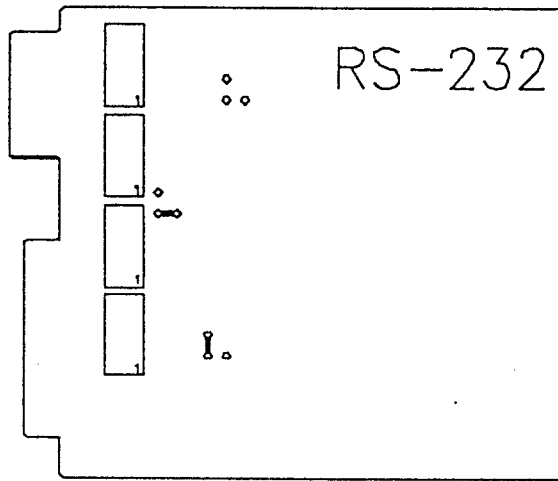
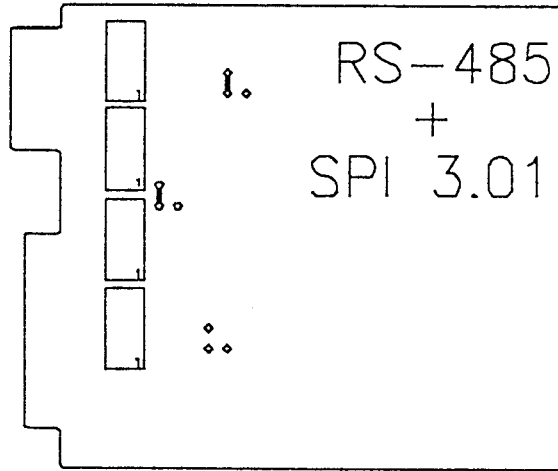

Figure 4. CIM Communications Jumper Selection

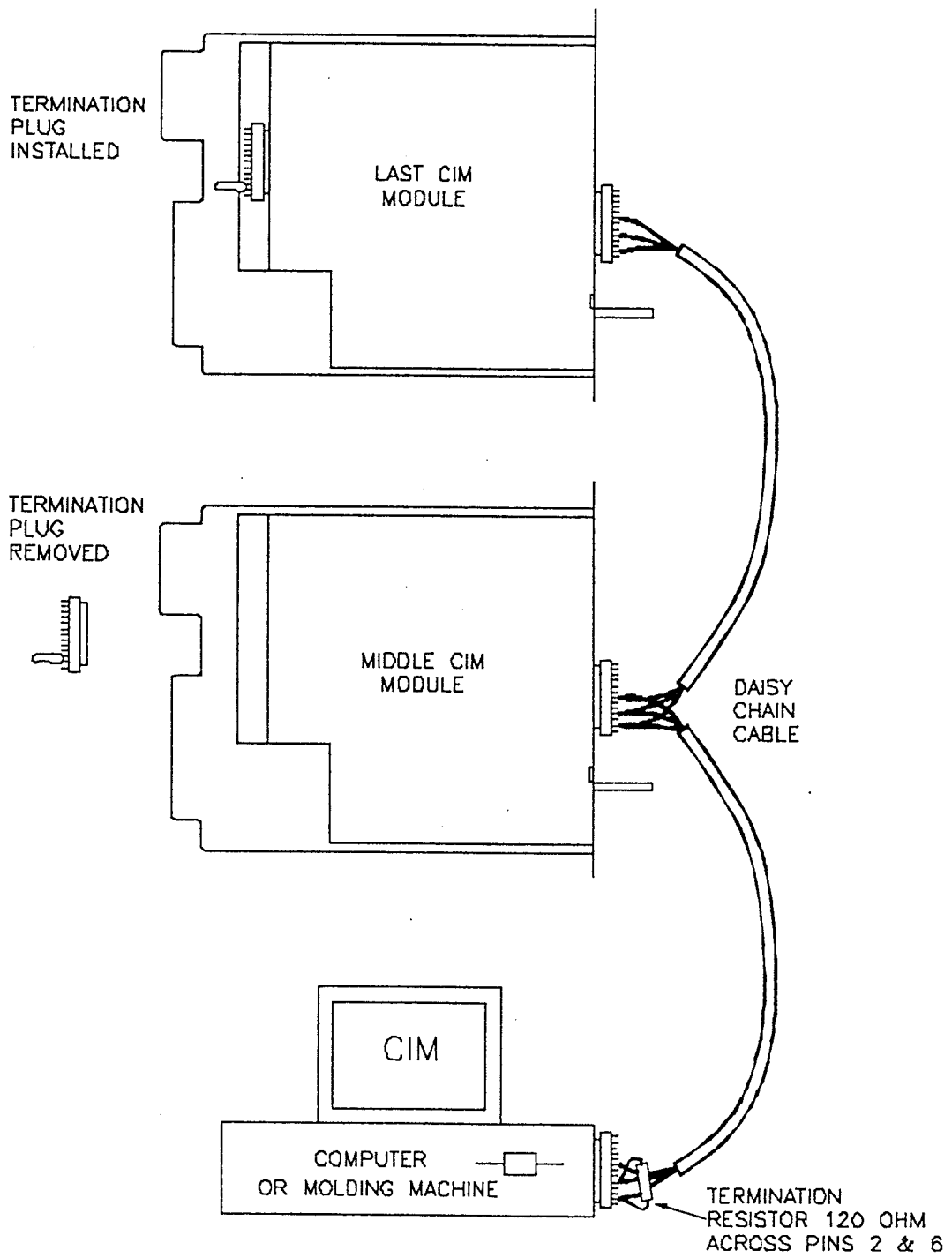
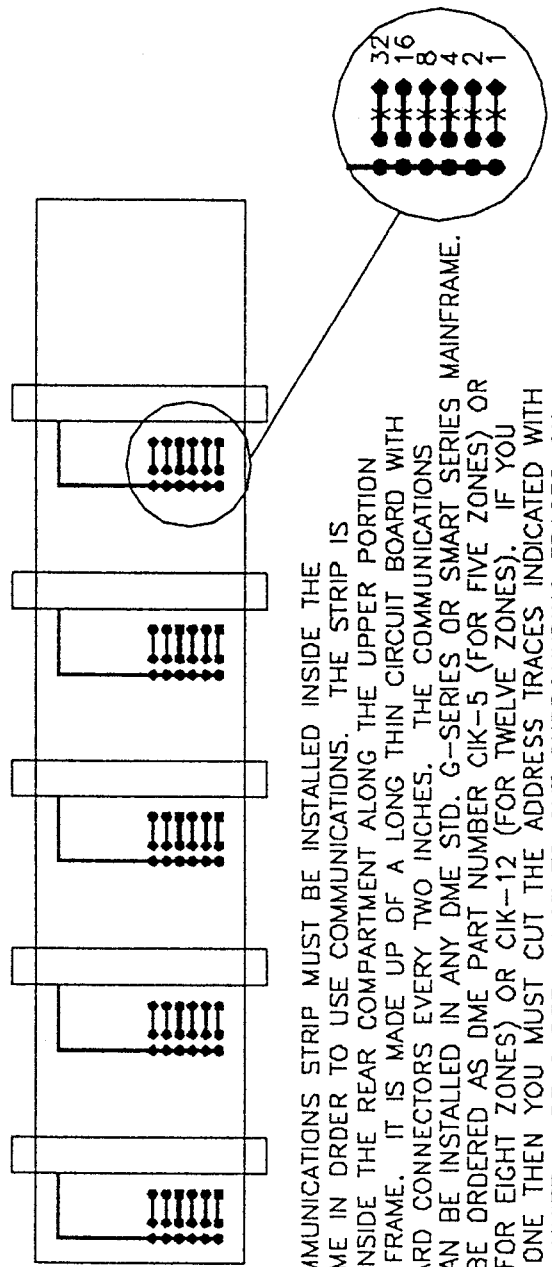

Figure 5. Termination Resistor Configuration for EIA-485

CUT TRACES INDICATED BY AN X						
ZONE NO.	32	16	8	4	2	1
1						X
2					X	X
3					X	X
4				X	X	X
5				X	X	X
6				X	X	X
7				X	X	X
8				X	X	X
9				X	X	X
10				X	X	X
11				X	X	X
12				X	X	X
13				X	X	X
14				X	X	X
15				X	X	X
16		X	X	X	X	X
17		X	X	X	X	X
18		X	X	X	X	X
19		X	X	X	X	X
20		X	X	X	X	X
21		X	X	X	X	X
22		X	X	X	X	X
23		X	X	X	X	X
24		X	X	X	X	X
25		X	X	X	X	X
26		X	X	X	X	X
27		X	X	X	X	X
28		X	X	X	X	X
29		X	X	X	X	X
30		X	X	X	X	X
31		X	X	X	X	X
32	X	X	X	X	X	X
33	X	X	X	X	X	X
34	X	X	X	X	X	X
35	X	X	X	X	X	X
36	X	X	X	X	X	X
37	X	X	X	X	X	X
38	X	X	X	X	X	X
39	X	X	X	X	X	X
40	X	X	X	X	X	X
41	X	X	X	X	X	X
42	X	X	X	X	X	X
43	X	X	X	X	X	X
44	X	X	X	X	X	X
45	X	X	X	X	X	X
46	X	X	X	X	X	X
47	X	X	X	X	X	X



THE COMMUNICATIONS STRIP MUST BE INSTALLED INSIDE THE MAINFRAME IN ORDER TO USE COMMUNICATIONS. THE STRIP IS FOUND INSIDE THE REAR COMPARTMENT ALONG THE UPPER PORTION OF THE FRAME. IT IS MADE UP OF A LONG THIN CIRCUIT BOARD WITH EDGE CARD CONNECTORS EVERY TWO INCHES. THE COMMUNICATIONS STRIP CAN BE INSTALLED IN ANY DME STD. G-SERIES OR SMART SERIES MAINFRAME. IT CAN BE ORDERED AS DME PART NUMBER CIK-5 (FOR FIVE ZONES) OR CIK-8 (FOR EIGHT ZONES) OR CIK-12 (FOR TWELVE ZONES). IF YOU INSTALL ONE THEN YOU MUST CUT THE ADDRESS TRACES INDICATED WITH A SHARP KNIFE - BE CAREFUL NOT TO CUT SURROUNDING TRACES ON THE CIRCUIT BOARD.

Figure 6. Communications Strip - Address Chart

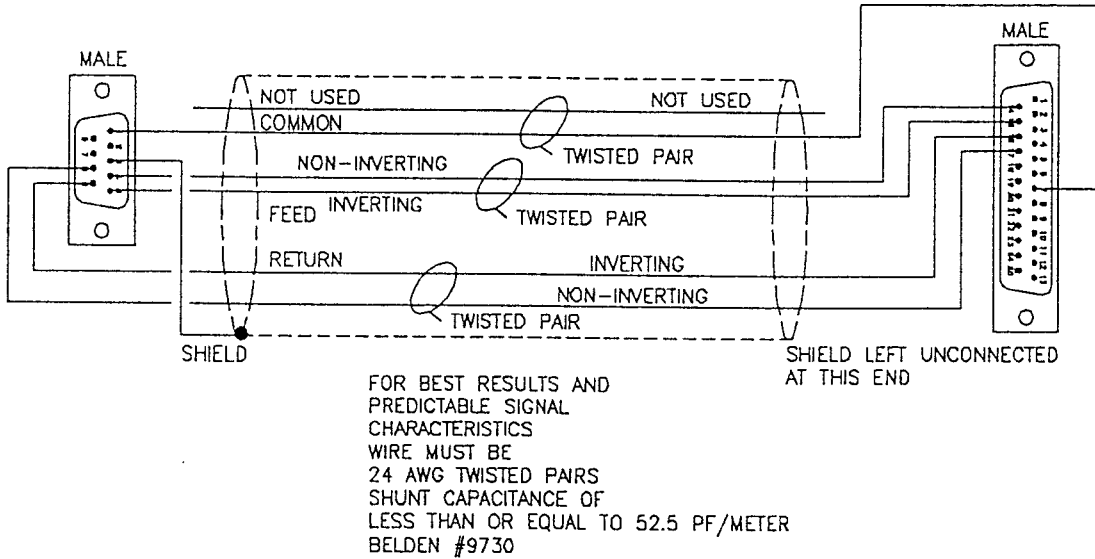

Figure 7. Standard CIM Communications Cable
For SPI3.01 and RS 485 (EIA 485)

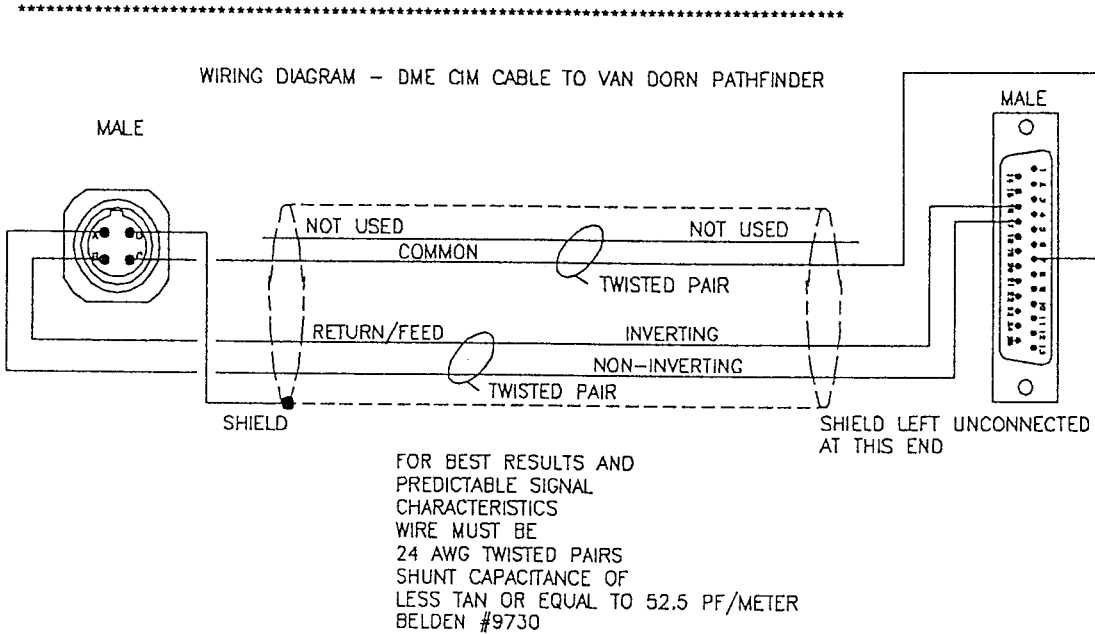

Figure 8. Van Dorn Pathfinder CIM Communications cable