

# D-M-E Collapsible Core and Collapsible Mini-Core



# TABLE OF CONTENTS

## D-M-E Collapsible Core & Collapsible Mini-Core

This data is designed to assist you in using the D-M-E Collapsible Core and Collapsible Mini-Core. Included are core, mini-core and mold base machining dimensions and data. Provided as well are design checklists, mold starting procedures, and core, mini-core and center pin grinding instructions. Drawings are also included for an early ejector return for reference when one is required.

Should you require further assistance, contact your D-M-E Customer Service Representative (see phone numbers below) to put you in touch with the D-M-E Applications Engineering Department or your local D-M-E Field Representative.

### Collapsible Core

<b>D-M-E Collapsible Core</b> .....	<b>.3-65</b>
Description of Components and Basic Operation .....	.3-5
Sequence Description .....	.6
Design Procedure .....	.7-8
Part Design – Detail Requirements .....	.9
Table of Dimensions and Drawing Figures .....	.10-11
Design Check List and Mold Start-up Procedures .....	.12-13
Grinding Recommendations .....	.14
Grinding Instructions – Center Pin, D-6 Steel .....	.15
Alterations to Collapsible Cores .....	.16
CC 200 P.C. Dimensions .....	.17-21
CC 250 P.C. Dimensions .....	.22-26
CC 202 P.C. Dimensions .....	.27-31
CC 252 P.C. Dimensions .....	.32-36
CC 302 P.C. Dimensions .....	.37-41
CC 352 P.C. Dimensions .....	.42-46
CC 402 P.C. Dimensions .....	.47-51
CC 502 P.C. Dimensions .....	.52-56
CC 602 P.C. Dimensions .....	.57-61
Collapsible Core Mold Base Ordering Guide .....	.62
Collapsible Core Ordering Guide Drawings .....	.63
Early Ejector Plate Return – Plate Machining Dimensions .....	.64
Early Ejector Plate Return – Operating Sequence .....	.65

### Collapsible Mini-Core

<b>D-M-E Collapsible Mini-Core</b> .....	<b>.66-99</b>
Description of Components and Basic Operation .....	.66-69
Sequence Description .....	.70
Design Procedure .....	.71-72
Part Design – Detail Requirements .....	.73
Table of Dimensions and Drawing Figures .....	.74-75
Design Check List and Mold Start-up Procedures .....	.76-77
Mini-Core O.D., as well as Collapsing Segment Thread and Undercut Grinding Recommendations .....	.78-79
Center Pin Cut-off and Grinding Instructions .....	.80
Alterations to Collapsible Mini-Cores .....	.81
Mini-Core Grinding Set-up Information .....	.82
CCM-0001 Dimensions .....	.83-87
CCM-0002 Dimensions .....	.88-92
CCM-0003 Dimensions .....	.93-97
Collapsible Mini-Core Stripper Plate Mold Base Ordering Guide .....	.98
Collapsible Mini-Core Ordering Guide Drawings .....	.99

**Questions? Call D-M-E at 1-800-626-6653 (U.S.) • 1-800-387-6600 (Canada) • 32-15-215011 (Europe)**

# D-M-E COLLAPSIBLE CORE

## D-M-E Collapsible Core: Description of Components and Basic Operation

The D-M-E Collapsible Core is a three-unit assembly designed for simplicity of installation, reliability in operation and long life. The three units are a Collapsible Core, center pin, and a positive collapse sleeve.

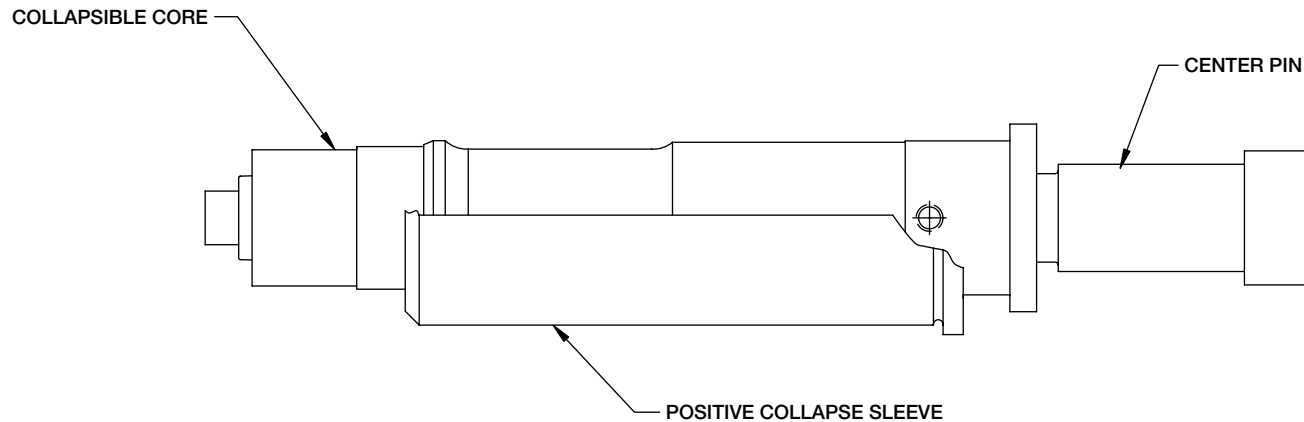

### Center Pin

The Center Pin serves to expand the segments of the Collapsible Core to their molding position and holds them at this diameter. A hole is provided inside the pin for cooling. The center pin is manufactured of a high alloy Type D-6 steel hardened to 60 to 65 Rockwell C. Refer to the pin grinding instructions for machining directions. In use the pin must incorporate two design features. The pin must protrude beyond the face of the collapsing core segments by certain amounts (refer to Dimension F, Table 1-1). This protrusion keeps material from flowing under the face of the collapsing segments and preventing their collapse. A radius must be applied to the outside corner at the front of the center pin. The sharp edge resulting from cutting the pin to length will gall and subsequently destroy the inside surfaces of the collapsing core segments (refer to Dimension R, Table 1-1).

The standard plate machining dimensions provided in the Technical Data and Drawings assume a maximum pin protrusion of .075 inches. *When greater protrusion is needed, certain dimensions in the mold base must be altered; consult D-M-E. Center pins are fitted to a specific core and cannot be interchanged.* Always verify serial numbers prior to grinding or assembly. Replacement pins to fit a Collapsible Core are available.

## D-M-E COLLAPSIBLE CORE

### D-M-E Collapsible Core: Description of Components and Basic Operation (cont.)

#### Collapsible Core

The Collapsible Core is manufactured from A.I.S.I. Type A-2 steel hardened to 51 to 57 Rockwell C. It is designed to collapse independently when the center pin is withdrawn. The fit between segments is controlled to permit flash free molding. The location of the core on its pin is critical. *The distance between the back of the core flange and the front of the center pin flange (Head Space) is critical and must be maintained.* If the Head Space ( $1.938 \pm .005$  on a CC 202 PC) is not maintained, unsatisfactory operation will result, or the core may be permanently damaged. The unit is designed to operate without benefit of lubrication. Treating the Collapsible Core with an alloying process for wear reduction or corrosion resistance is possible; contact D-M-E. Plating the Collapsible Core is not recommended.

The individual segments have a “self-cleaning” action and will tend to carry any dirt or deposits to the outer surface of the collapsing core. The first 50 to 100 shots in operation may show foreign matter deposits on the inside of the molded part. Prior to final assembly of the mold, the Collapsible Core should be thoroughly degreased and cleaned. It is recommended a light wipe of grease or PTFE lubricant, can be given to the tapered end of the center pin for break-in purposes.

It is recommended that the collapsing core be free to turn when installed in the ejector plate. This slight play will permit the core flange to “float” slightly therefore helping it find its own center, and equalizing wear on the center pin.

To completely collapse the core, the center pin must be withdrawn a specified amount. This distance between the back of the rear support plate and the front of the ejector retainer plate is  $2.187 \pm .005$  for the Type CC-202-PC. It varies for different models of the core. This dimension and the .207 deep counterbore must be held to permit full collapse of the core and to permit correct operation of the positive collapse sleeve. If necessary to deviate from this dimension, consult D-M-E.

Stripper plate actuation must be so sequenced that the cylinders have returned the stripper plate before the ejector plate has returned. This will avoid interference of the stripper ring with the core and possible core damage (see Sequence Description).

Collapsible cores are individually fitted to a matching numbered pin, and cannot be interchanged.

The Collapsible Core has twelve collapsing segments. The molding diameter may indicate an out-of-round or stepped condition after grinding. This may have been due to an over-tight grinding ring or improper headspace. Stepping and/or witness lines on the core O.D. or core face can result from excessive injection pressure.

## D-M-E Collapsible Core: Description of Components and Basic Operation (cont.)

### Positive Collapse Sleeve

The Positive Collapse Sleeve (PC sleeve) is designed to function when the Collapsible Core fails to collapse independently upon withdrawal of the center pin. In normal operation, the PC sleeve is not functioning. It is essential to have such a unit for maximum safety and reliability in automatic and semi-automatic operation. Under no circumstances should a mold be placed into automatic operation without the use of the PC sleeve.

The PC sleeve is uncomplicated in operation. An angular surface on the inside of the front edge of the PC sleeve will engage a matching angular surface on the outside of the Collapsible Core should the un-collapsed core be moved forward in the PC sleeve. This interference action is achieved by restricting the travel of the PC sleeve to an amount less than the forward travel of the Collapsible Core.

It is essential that no variation be permitted from the dimension given between the rear of the back support plate and the front of the ejector retainer plate. The .207 +.003-.002 deep counterbore must also be maintained. *Do not deviate from these dimensions without prior approval of D-M-E.* Any variation from these dimensions will adversely affect the operation of the PC sleeve and may cause destruction of the core.

PC sleeves are interchangeable between different serial numbers of the same catalog number (size) core.

## D-M-E COLLAPSIBLE CORE

### Desired Sequence of Operation of Collapsible Core for Automatic Mold Operation

As seen on each “Mold Base Machining Dimension” sheet in the D-M-E Collapsible Core Technical Data Book, the cross section depicts a typical collapsible core mold design. The collapsible core is mounted in the ejector retainer plate; the center pin is mounted in a bottom clamp plate. An extended stripper plate has been incorporated for proper ejection and cylinders are shown installed for the last stage of the required two-stage ejection. Also, vital to the design is the usage of guided ejection.

The molding sequence can easily be followed by starting with the opening of the press: the press opens and the mold parts at the main parting line. When sufficient mold open is achieved, the ejector plate assembly is moved forward by mechanical or hydraulic knockouts of the press. The ejector plate assembly with the collapsing core is moving forward the necessary stroke required to move the core off of the center pin and collapse the core (this is the first stage of ejection).

If the segments of the core fail to collapse for any reason during this stage, the positive collapse sleeve will come into play and ensure the start of the collapse. In addition, the stripper plate and ejector plate assembly move together because of the return pins located directly under the stripper plate. This simultaneous movement continues until the ejector plate assembly is full forward. At this point, a limit switch is actuated. This in turn actuates the cylinders to take over and to continue to move the stripper plate with the stripper insert, moving the part away from the collapsed core (second stage).

When automatic part stripping is required, means must be provided for carrying the molded part off of the collapsed core at the completion of the ejector stroke. This is commonly done by providing a ring projection (.010 x .010 min.) on the face of the stripper insert. Shock dislodges the part from this ring and permits it to drop out of the mold at the end of the stripper stroke. The part must not drag over the core. When removing the part manually, the stripper ring and the cylinders are not required.

Please note that the stripper plate actuation must be sequenced so that the cylinders have returned the stripper plate before the ejector plates are returned. This applies to all parts whether through molded or not. The stripper plate must always be returned to its original position before re-expanding the core. This will avoid interference of the stripper insert with the core and possible core damage.

When the top face of the collapsible core shuts off against the cavity, all cores must be ground to the same overall length. In addition, whenever this condition exists, an early ejector return must be employed. The early ejector return will ensure that the core is expanded before the mold closes at the parting line.

## Design Procedure – Plastic Parts to be Molded on Collapsible Cores

### General Considerations

All commonly used thermoplastic molding resins, including filled materials, have been successfully molded on Collapsible Cores. Vinyl resins have been tried. Certain injectable thermosets have also been tried. However, cores must be treated with corrosion resistant process, such as a dense nodular chrome (contact D-M-E). (However, in general, we cannot recommend thermosets due to extreme ease of flashing and the very abrasive nature of many of these materials.) For high temperature applications over 650°F, contact D-M-E.

Good plastic design practice should be observed to avoid such conditions as distortion, sink marks, etc. These problems and their solutions are identical to those found in conventional molding. Adequate venting is important. Gases must always be vented to the outside of the part away from the core and center pin.

The illustrations contained in this document show only the very simplest type of part which can be molded on Collapsible Cores. Molded parts need not be closed at one end. They may be partially open or even completely sleeve shaped. Undercuts need not be continuous. Openings may be formed in the sidewall of molded parts by extending projections on the surface of the Collapsible Core to shut off against the cavity wall. *However, please contact D-M-E Applications Engineering Department concerning these types of shut-offs and for specific requirements concerning unusual applications and for special requirements and questions concerning the Collapsible Core.*

### Part Design – Molding Feasibility

The following steps are used to determine if a part can be molded on the Collapsible Core (refer to figures and tables on the following pages):

#### Undercut

- ◆ Determine that undercuts C required by the part design do not exceed the collapse available in the Collapsible Core. Identify all actual undercuts on the part drawing, and define the effective location of L for each one, as follows (see Table 1-1 and Figure 1-1).
- ◆ An undercut is defined as “one-half of the difference between any larger diameter and all smaller diameters located at a greater distance from the end of the Collapsible Core”  $[.5 \times (B-A)]$ .
- ◆ Determine that the part major diameter B (the largest interior diameter) is not greater than the B maximum value in Table 1-1 and Figure 1-1.
- ◆ Determine that the part minor diameter A (the smaller interior diameter) is not less than the A minimum value in Table 1-1 and Figure 1-1.
- ◆ The location L of such an undercut is defined as “the distance from the face of the Collapsible Core to the largest diameter producing the undercut.”
- ◆ The amount of collapse listed is the amount that is achieved by the segments to obtain the fully collapsed dimension.



## D-M-E COLLAPSIBLE CORE

### Design Procedure – Plastic Parts to be Molded on Collapsible Cores (cont.)

#### Loss of Collapse

When collapsed, the core segments bend inward at about  $1^\circ$ . The collapse available decreases from the front of the core at the rate of .020/in. per side. In determining part design feasibility the maximum part undercut must be computed using the loss of the collapse factor (.020 x L). For example, a core collapsing .080 at the face of the segment will only have .060 collapse available 1" back: .080-(.020 x 1.000). Based on the information it is obvious that part design must allow for the decrease in collapse of the core as a factor of part depth.

#### Shrinkage

Calculate the expected actual shrinkage "S" of the part along its diameter.

**NOTE:** In actual use, less than one-half of the material shrinkage occurs in the mold. You may, based on your experience, compensate for this by using one-half of the total material shrinkage in computing S.

#### Clearance

Use .005 clearance/side on all cores.

#### Total Collapse

Undercut + Loss of Collapse + Shrinkage + Clearance = Total Collapse Per Side at Top of Core.

**NOTE:** Make sure total collapse does not exceed maximum collapse in Table 1-1 Item C.

**IMPORTANT:** Determine that part depth D does not exceed the value given in Table 1-1 and Figure 1-1. For special applications, consult the D-M-E Company Applications Engineering Department.

Verification of basic dimensions A, B, C, and D, (Table 1-1 and Figure 1-1) assure that the part does not exceed design limits of standard Collapsible Cores. Departure from standards is frequently possible with specially designed units. Consult D-M-E Company Applications Engineering Department to determine if it is possible to make a special core for your application if it should fall outside the standard core range (including longer molding lengths, special diameters, special collapse and even numbers and size of segments).

**Questions? Call D-M-E at 1-800-626-6653 (U.S.) • 1-800-387-6600 (Canada) • 32-15-215011 (Europe)**



# D-M-E COLLAPSIBLE CORE

## Part Design – Detail Requirements

The design of the part must have the following details and features for successful operation:

1. The pin must protrude beyond the core face (see Fig. 1-2) by at least the distance F given in Table 1-1. A maximum protrusion of up to .075 is permissible. For protrusions greater than .075, contact D-M-E to determine special conditions. The minimum pin tip Radius R must be used.
2. There must be no undercuts on the face of the core segments (see Fig. 1-2). This would prevent the Collapsible Core from functioning.
3. Any undercuts on the face of the pin (see Fig. 1-2) must not interfere with full radial inward movement of the Collapsible Core segments. They must either be located forward of the core face, or be confined within a diameter smaller than the collapsed inside diameter G (see Table 1-1) of the Collapsible Core. In no case should the undercuts be so deep that they come close to the cooling hole in the center pin. Special pins can be supplied for these cases (see Collapsible Core dimension drawing).
4. The core face (see Fig. 1-2) must have a draft of at least 3° starting no further than .030 from the surface of the pin.
5. All undercuts should be drafted. A minimum draft of 5° is required (see Fig. 1-2). Interrupted undercuts (see Fig. 1-3) also require a side draft of at least 5°.
6. Means must be provided for carrying the molded part off the collapsed core at the completion of the ejector stroke. This is commonly done providing a ring projection (.010 x .010 min.) on the face of the stripper bushing (see Fig. 1-2). Shock dislodges the part from this ring and permits it to drop out of the mold at the end of the stripper stroke. The part must not drag over the core.

**NOTE:** This feature may be omitted when automatic part stripping is not specified.

7. As in conventional practice, sharp interior corners must be avoided to prevent stress concentration in the steel.

# D-M-E COLLAPSIBLE CORE

## Table of Dimensions

Table 1-1

COLLAPSIBLE CORE	200/250	202/252	302/352	402	502	602
<b>A</b> Minimum Part, Minor Diameter	.910-S	1.010-S	1.270-S	1.593-S	2.060-S	2.610-S
<b>B</b> Maximum Part, Major Diameter	1.270-S	1.390-S	1.740-S	2.182-S	2.800-S	3.535
<b>C</b> Maximum Part Undercut at L (see text)	.043/.048-† (.020xL) -(1/2 x S)	.055/.064-† (.020xL) -(1/2 x S)	.068/.083-† (.020xL) -(1/2 x S)	.090/.103-† (.020xL) -(1/2 x S)	.115/.125-† (.020xL) -(1/2 x S)	.140/.148-† (.020xL) -(1/2 x S)
<b>D</b> Maximum Part Depth – Shut-off K (see text)	.975/1.150 -K	.975/1.150 -K	1.225/1.40 -K	1.535/1.700 -K	1.750/1.900 -K	2.125/2.400 -K
<b>E</b> Molding Length on Core (minimum) + Mold Shut-off	.975 or 1.150*	.975 or 1.150*	1.225 or 1.400*	1.535 or 1.700*	1.750 or 1.900*	2.125 or 2.400*
<b>F</b> Pin Protrusion, Minimum (see text)	.015	.015	.020	.030	.035	.045
<b>G</b> Inside Diameter, Collapsed Core Nominal – Fig. 1-3	.470	.470	.590	.725	.945	1.200
<b>H</b> Pin Diameter at Face – .005	.785	.885	1.105	1.388	1.750	2.175
<b>K</b> Stripper Bushing Seal-Off Length Recommended Minimum (see Fig. 1-2)	.150	.150	.150	.200	.250	.250
<b>R</b> Pin Tip Radius Minimum (see Fig. 1-2)	.008	.008	.008	.012	.015	.020
<b>S</b> Material Shrinkage (see text)	Shrinkage Factor x Part Diameter					

\*Cores with longer molding length are subject to availability. Contact D-M-E.

†Cores with larger than minimum collapse are subject to availability. Contact D-M-E.

**Questions? Call D-M-E at 1-800-626-6653 (U.S.) • 1-800-387-6600 (Canada) • 32-15-215011 (Europe)**

# D-M-E COLLAPSIBLE CORE

## Figures for Table of Dimensions

Fig. 1-1A

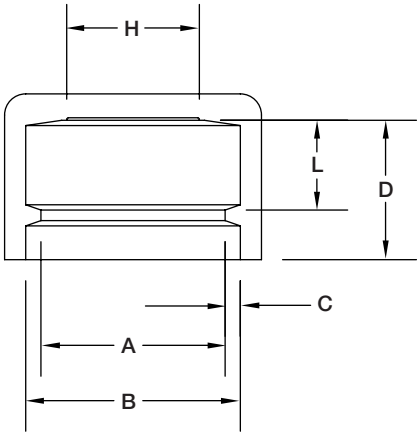

Fig. 1-1B

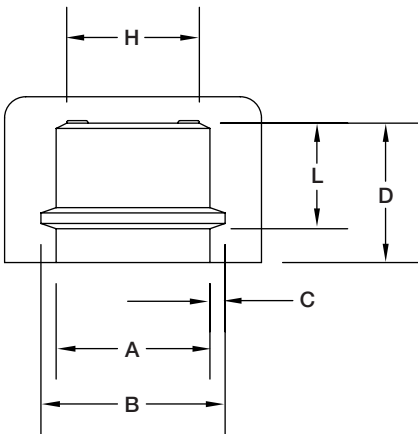

Fig. 1-2

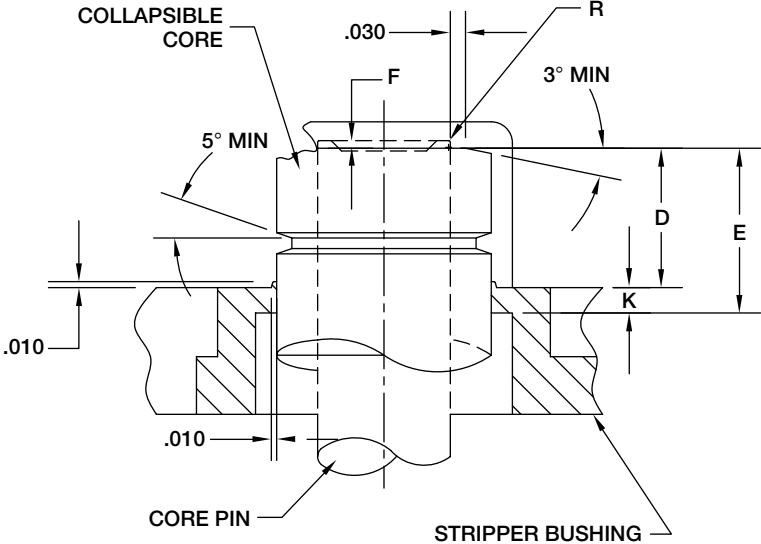
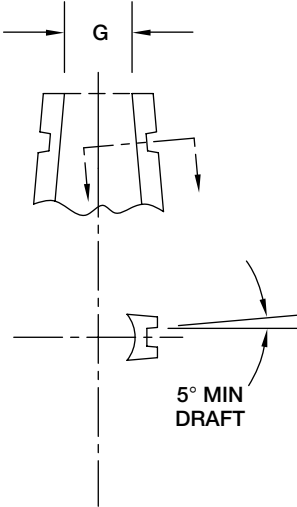

Fig. 1-3



### Design Check List and Mold Start-up Procedures

Things to look for in mold design and in checking out molds prior to operation:

1. Use guided ejector plates, and support ring around center pin between ejector plate and ejector housing or back clamp plate (doughnut around pin).
2. First break to occur at main parting line. Use springs to assure.
3. Return pins to be located under, not through, stripper plate.
4. Ejector travel to specification, stamp on edge of ejector plate.
5. Secondary stripper actuation only after full ejector plate travel. Use properly set micro-switch or other means. Stripper-plate must return fully before ejector plate begins return (see Sequence Description).
6. When top face of Collapsible Core segments shut off against cavity (for some parts with through holes), all cores must be ground to same length overall. Normal core tolerance of plus or minus .003 is inadequate. Whenever the above condition exists, an early ejector return system must be used. Clearance between end of core segments and cavity to be .0005/.001. Do not pre-load.
7. Good venting essential, preferably to outside of mold at parting line.
8. Clearance between core and stripper bushing (.0010/.0015 total) on diameter at room temperature. No tapered mold seal-off below thread or configuration. Measure O.D. of core at stripper bushing when core is installed in mold with stripper plate removed.
9. Verify for center pin protrusion and pin tip radius. Examine pins for evidence of any de-temper of pin tip due to overheating in grinding.
10. Mounted core in ejector plate assembly to be free to turn if part design allows.
11. Center pin and stripper bushing to be concentric. Water line baffle in center pin sometimes tends to throw pin off, or pin may be improperly mounted.
12. Positive collapse sleeve to travel freely, when both starting up, and when mold is at operating temperature. Grease lightly.
13. Check finish on cores:
  - ◆ Surface finish and polish.
  - ◆ Undercuts and back-hooks in direction of collapse due to improper grinding.
  - ◆ Compliance with proper design procedures.

### Design Check List and Mold Start-up Procedures (cont.)

14. Observe proper care in dry cycling:
  - ◆ Plate cocking or bounce.
  - ◆ Audible sounds or visible indications of friction, misalignment or scoring.
  - ◆ Sequence of motions (see Sequence Description).
  - ◆ Positive collapse action.
15. Threads ground into Collapsible Core should not run out to a feather/knife edge.
16. Refer to Sequence Description for desired Sequence of Automatic Mold Operation.

# D-M-E COLLAPSIBLE CORE

## Grinding Recommendations – Collapsible Core

### A – General

1. Cores and pins must be clean prior to assembly for grinding. A coating of lightweight rust preventive is recommended.
2. Assemble core to pin as specified in installation drawing, using three set screws (supplied) tightened against pin to prevent shifting during grinding. Concentricity of core pin is extremely important.

**NOTE:** Cores are assembled prior to shipment, but must be re-set by grinder because of possibility of movement in transit.

3. During grinding, do not use air blast or water jet at high pressure for cooling, since this may force grinding grit between segments.
4. Select a grinding wheel suitable for grinding A.I.S.I. type A2 Steel (air hardening tool steel) of approximately 55 Rockwell C.

### B – Procedure

1. With core assembly prepared as outlined above, rough-grind desired molding and seal-off diameters approximately .008" oversize. During rough grind place clamping ring (customer to manufacture) as far forward (toward nose of core) as possible. If necessary, the maximum distance the clamping ring may be located away from the core face is not to exceed the following dimensions:

CORE TYPE	MAX. DISTANCE OF CLAMPING RING SCREW FROM CORE FACE
CC-200 SERIES	1.250 inches
CC-300 SERIES	1.500 inches
CC-400 SERIES	1.875 inches
CC-500 SERIES	2.125 inches
CC-600 SERIES	2.375 inches

Fig. 1-4

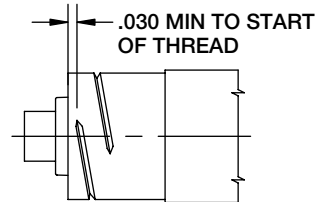

2. Remove clamping ring, disassemble core and pin, and clean components as above. Re-assemble as above for final grinding.
3. To grind final dimensions, it is recommended that the clamping ring be applied over the seal-off area during grinding of the molding area, and vice versa. Only if this is impossible should the clamping ring be applied beyond the seal off area. Do not exceed the limits specified above.
4. Polish the ground areas as required for surface finish. Whenever a buffing wheel is used, the clamping ring must be applied to prevent possible damage to the segments.
5. After completion of the grinding and polishing, the Collapsible Core should be de-magnetized. This facilitates cleaning, and reduces the chance of metallic chips adhering to the Collapsible Core.
6. Never permit a ground thread to run out through the face of the core. This leaves a knife-edge of steel that will break off in time. Instruct the grinder to lift the thread-grinding wheel out of the core before the thread breaks through the core face (see Fig. 1-4).

**Questions? Call D-M-E at 1-800-626-6653 (U.S.) • 1-800-387-6600 (Canada) • 32-15-215011 (Europe)**

## Grinding Instructions – Center Pin, D-6 Steel

### General Directions

D6 Steel is a high carbon, high chrome steel, hardened to over 60 Rockwell on the C scale. At all times grinding must be done under a coolant flood, using a coolant suitable for hardened tool steels.

**IMPORTANT:** Lack of sufficient cooling, heavy cuts, rapid plunging or in-feeding, will result in overheating and a loss of hardness, or heat checking and cracking.

The center pin has been ground on its own centers. The Collapsible Core has been ground true to the centers of the pin supplied with the unit. For set-up, refer to Grinding Recommendations – Collapsible Core.

### Step 1

Wire EDM cut-off is preferred. Cutting off the center pin can also be done with a resin cut-off wheel, in a universal grinder with the center pin rotating and heavy flood coolant. Use coolant suitable for hardened tool steels.

- ◆ When cutting off the tapered end: the flange is chucked and the long straight diameter beyond the flange is held in a steady rest, as close to the taper as possible. Indicate true before cutting off. Leave .025-.035 stock for final facing. Flood coolant must be used.
- ◆ When cutting off the flange end: the center pin can be chucked on the long straight diameter beyond the flange. Indicate true before cutting off. Leave .025-.035 stock for final facing. Flood coolant must be used.

### Step 2

Final facing of the center pin is done with an abrasive wheel in a universal grinder with the pin rotating, holding the pin in the same manner as when cutting off (see A and B, Grinding Recommendations). Flood coolant, suitable for hardened tool steels, must be used along with a slow feed. The wheel must be of soft grades (60-J, 46-J, etc.) and must be used with a sharp cutting land (important). See Fig. 1-5 at right. Surface grinding the O.A.L. is also acceptable under flood coolant.

Fig. 1-5

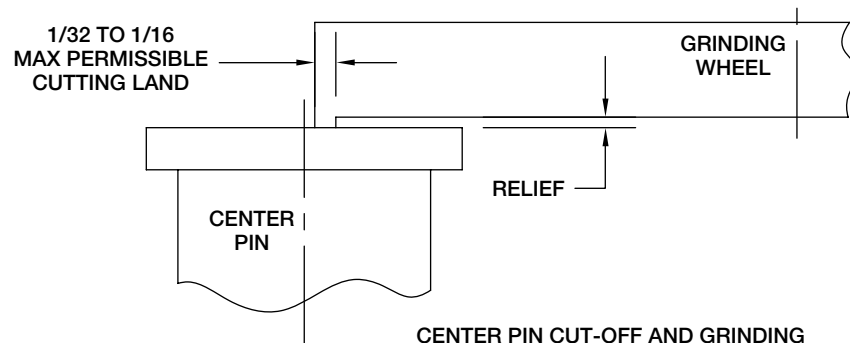



## D-M-E COLLAPSIBLE CORE

### Alterations to Collapsible Cores

Occasionally a need arises to shorten the overall length of a Collapsible Core or to do additional grinding on a Collapsible Core after it has been finish ground. In shortening the O.A.L. of a core, the following procedure should be used.

The core should be removed from its regular center pin and thoroughly cleaned. The core is then placed on a working pin for grinding. The working pin has a standard taper ground on the front end and has centers both front and rear. Insert the working pin into the Collapsible Core until the diameter of the core, when measured over the positive collapse bumps, coincides with this diameter as determined while the core is on its own pin with the head space set.

When using a working pin do not attempt to locate the core for grinding by setting its standard head space. This will almost never be the correct setting for the core since each core is individually custom fitted.

To shorten the core to a new length, a clamping ring is used and material is removed from the front of the core on a cylindrical grinder. The grinding wheel goes through the entire material of the core segments and cuts into the working pin to ensure a clean front surface. Core collapse will be decreased by .020 in./in. per side when O.A.L. is shortened.

It is obvious now why a working pin is used. If this grinding were performed on the core's regular center pin, the taper would be destroyed.

When a core has to be re-ground after its thread profiles have been finished and the centers on the regular center pin have been removed, again a working pin is used. The working pin is inserted into the core until the ground diameters of the core on the working pin coincide with the ground diameters of the core as finished. Again, the core is fixtured using the three screws at the mounting flange and the segments are held rigidly under a clamping ring. It is now possible to change the diameters on the working end of the core, or to deepen or enlarge the thread profiles.

After all finish grinding and polishing operations on the core are completed, it is important to demagnetize the core to prevent the adhesion of any metal particles which might find their way into cavities or between the segments during molding operations.



## D-M-E COLLAPSIBLE CORE

### CC 200 P.C. Core Dimensions (cont.)

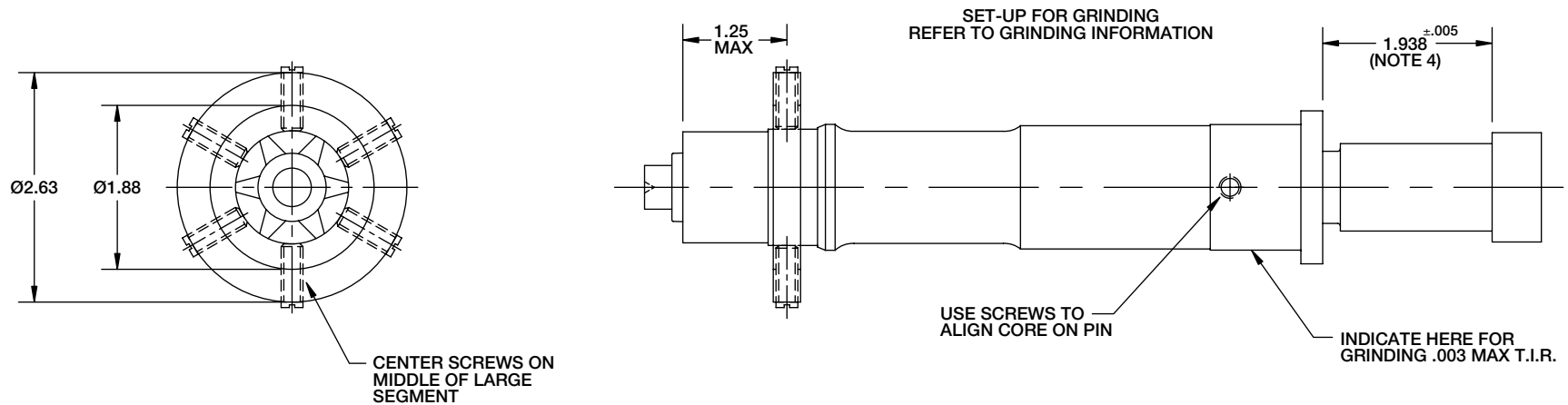

#### NOTES:

1. Center pin to project .015 minimum/.075 maximum above front face of Collapsible Core with .008 R minimum at corners. See suggested partial mold assembly view.
2. Both ends of center pin to be cut off after grinding contour on Collapsible Core before assembly in mold.
3. Minimum suggested I.D. of thread or undercut is .910-S to give minimum steel support between depth of undercut and center pin.
4. The  $1.938 \pm .005$  dimension must be held in mold assembly and core grinding.
5. Consult Grinding Instructions.
6.  $1/32$  radius essential on inside corners of stripper insert, especially where shut-off contacts Collapsible Core.
7. Thread must never be run out of face of core, leaving a knife-edge of material. For complete instructions, refer to Design Procedures.
8. Do not use center pin as a pilot into "A" half of mold.

Questions? Call D-M-E at 1-800-626-6653 (U.S.) • 1-800-387-6600 (Canada) • 32-15-215011 (Europe)

# D-M-E COLLAPSIBLE CORE

## CC 200 P.C. Mold Base Machining Dimensions

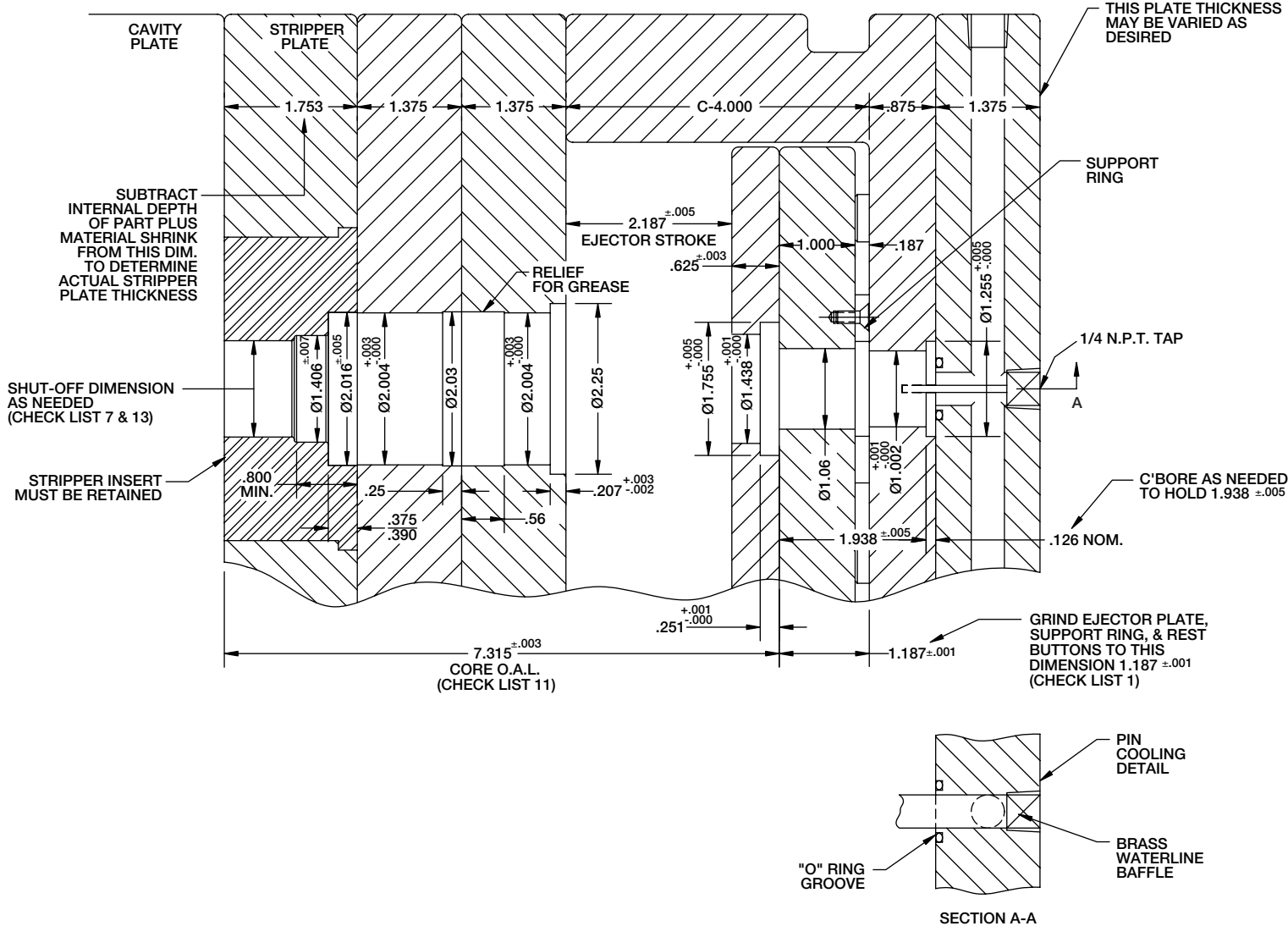

# D-M-E COLLAPSIBLE CORE

## CC 200 P.C. Mold Base Machining Dimensions (cont.)

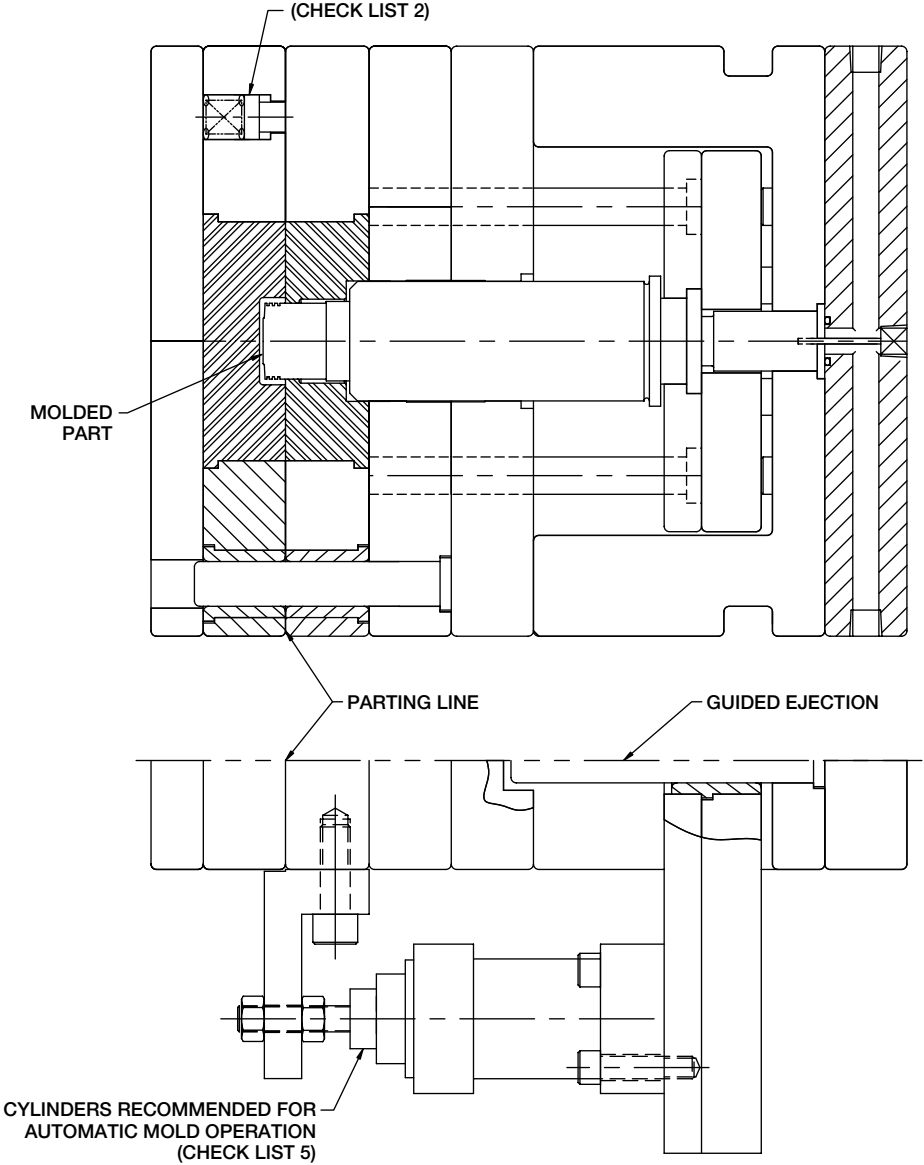

Questions? Call D-M-E at 1-800-626-6653 (U.S.) • 1-800-387-6600 (Canada) • 32-15-215011 (Europe)

### CC 200 P.C. Mold Base Machining Dimensions (cont.)

#### Mold Design Check List

1. Use guided ejector plates and a support ring around center pin. Ejector plate, support rings and rest buttons must be ground to  $1.187 \pm .001$ .
  2. Use springs to assure first break at main parting line.
  3. Return pins to end under stripper plate.
  4. Ejector plate travel to specifications. Stamp dimension on edge of plate.
  5. Secondary stripper plate actuation to begin only after full ejector plate travel. Stripper plate must return fully before ejector plate begins to return (see Sequence Description).
  6. Good venting is essential, preferable to outside of mold.
  7. Clearance between core shut-off O.D. and stripper insert I.D. to be  $.0010/.0015$  total. Measure core when installed in mold. No tapered shut-off permitted. Avoid excessive shut-off length;  $.150/.250$  is adequate.
  8. Mounted core to be free to turn when in ejector plate assembly.
  9. Center pin to be concentric with stripper bushing. Verify protrusion of pin through core and radius on tip of pin.
  10. Positive collapse sleeve to travel freely through plates. Apply grease where indicated. Check for free movement when mold is at operating temperature.
  11. When face of Collapsible Core segments shut-off against cavity (some parts with through holes), all cores must be ground to the same O.A.L. Normal tolerance of  $\pm .003$  is inadequate. Refer to Core Grinding Instructions. Clearance between end of core face and cavity to be  $.0005$  to  $.0010$ . Do not pre-load the core. Whenever the above condition exists, an early ejector plate return system must be used, or the cores will be destroyed.
- NOTE:** This applies only when the core seals off against the cavity. When the pin is seating against the cavity exercise care to avoid excessive pre-load of the pin. A  $.000$  to  $.0015$  interference is adequate.
12. Break all sharp corners.
  13. The stripper shut-off diameter must be of the same diameter or preferably a larger diameter than any other diameter on the core.

# D-M-E COLLAPSIBLE CORE

## CC 250 P.C. Core Dimensions

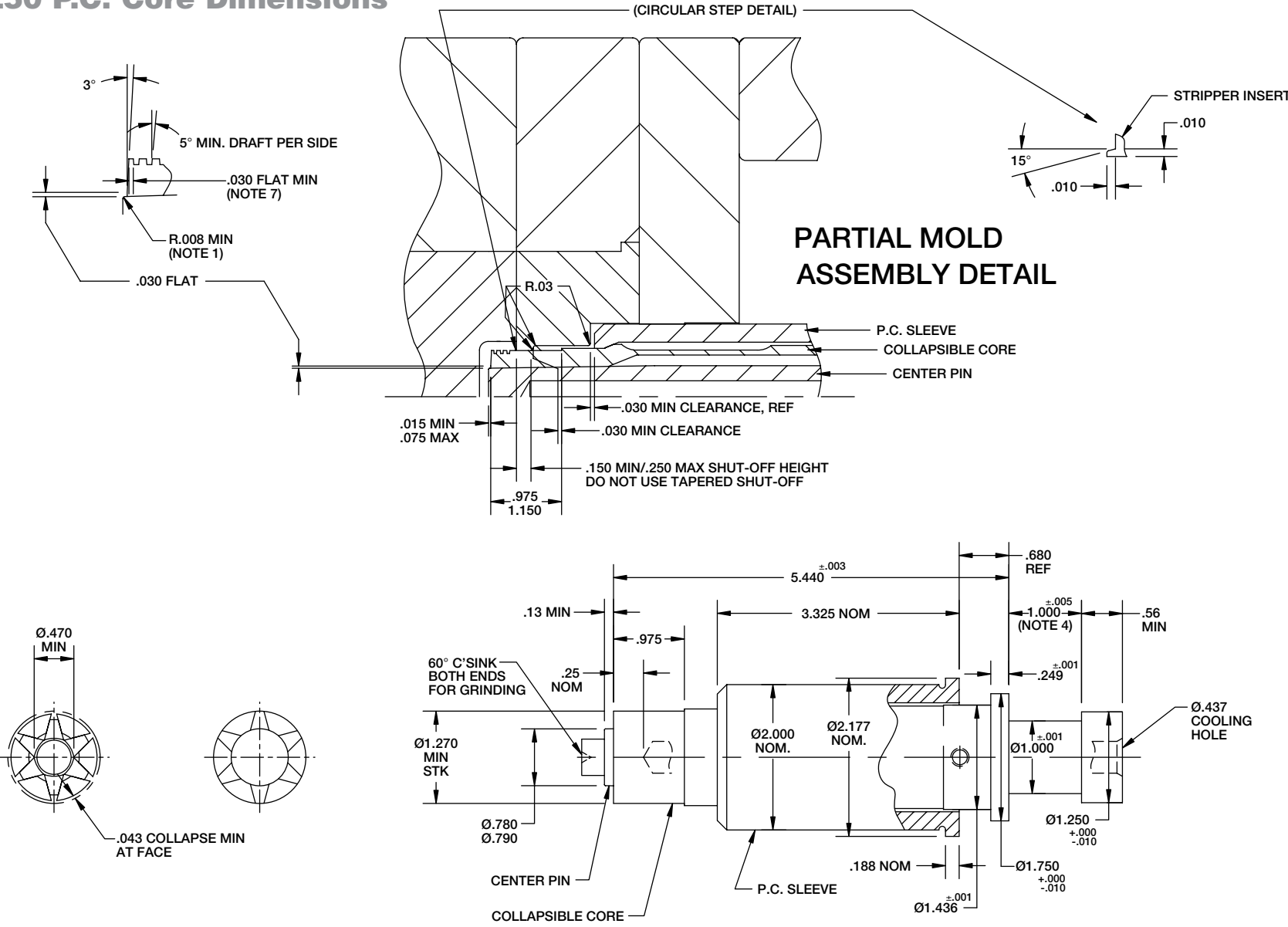

Questions? Call D-M-E at 1-800-626-6653 (U.S.) • 1-800-387-6600 (Canada) • 32-15-215011 (Europe)



## D-M-E COLLAPSIBLE CORE

### CC 250 P.C. Core Dimensions (cont.)

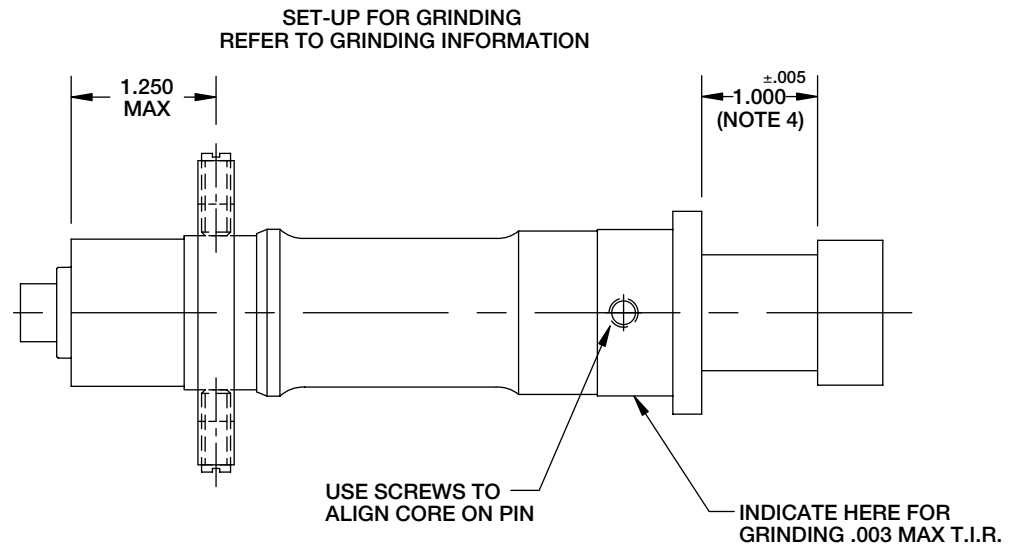
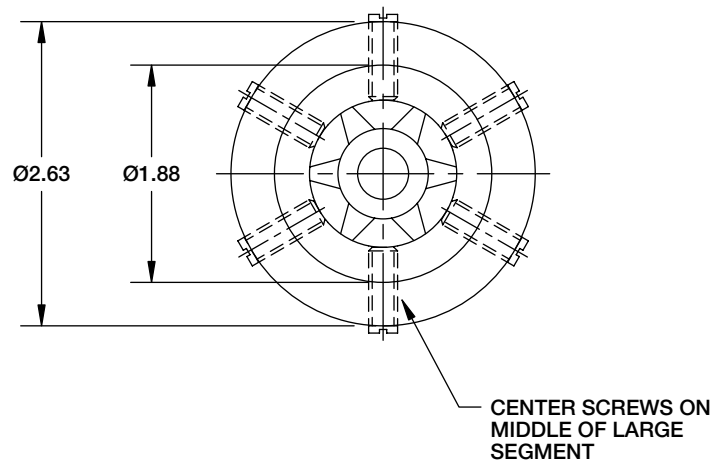

#### NOTES:

1. Center pin to project .015 minimum/.075 maximum above front face of Collapsible Core with .008 R minimum at corners. See suggested partial mold assembly view.
  2. Both ends of center pin to be cut off after grinding contour on Collapsible Core before assembly in mold.
  3. Minimum suggested I.D. of thread or undercut is .910-S to give minimum steel support between depth of undercut and center pin.
  4. The  $1.000 \pm .005$  dimension must be held in mold assembly and core grinding.
  5. Consult Grinding Instructions.
  6.  $1/32$  radius essential on inside corners of stripper insert, especially where shut-off contacts Collapsible Core.
  7. Thread must never be run out of face of core, leaving a knife-edge of material. For complete instructions, refer to Design Procedures.
  8. Do not use center pin as a pilot into "A" half of mold.
- NOTE:** Due to the reduction in mold plate thicknesses as compared to the CC-200-PC Collapsible Core, no greater than a four-cavity CC-250-PC Core mold is recommended.



# D-M-E COLLAPSIBLE CORE

## CC 250 P.C. Mold Base Machining Dimensions (cont.)

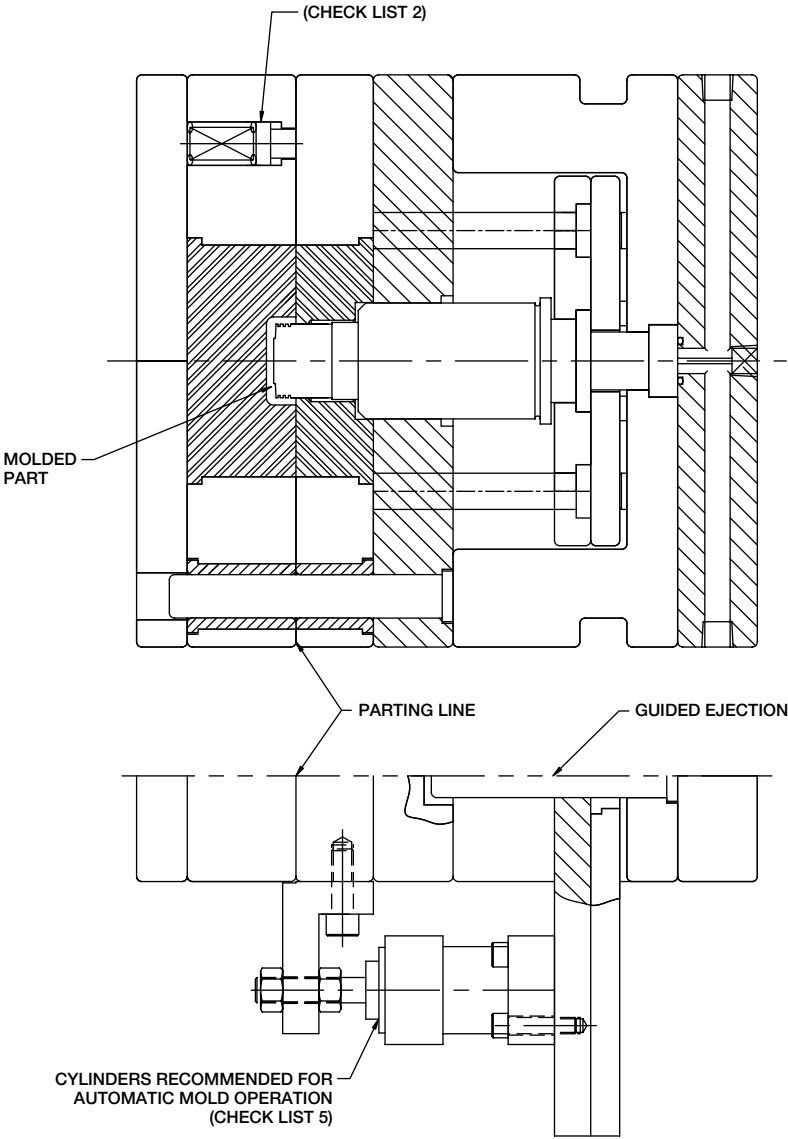

### CC 250 P.C. Mold Base Machining Dimensions (cont.)

#### Mold Design Check List

1. Use guided ejector plates and a support ring around center pin. Ejector plate, support rings and rest buttons must be ground to  $.625 \pm .001$ .
2. Use springs to assure first break at main parting line.
3. Return pins to end under stripper plate.
4. Ejector plate travel to specifications. Stamp dimension on edge of plate.
5. Secondary stripper plate actuation to begin only after full ejector plate travel. Stripper plate must return fully before ejector plate begins to return (see Sequence Description).
6. Good venting is essential, preferably to outside of mold.
7. Clearance between core shut-off O.D. and stripper insert I.D. to be  $.0010/.0015$  total. Measure core when installed in mold. No tapered shut-off permitted. Avoid excessive shut-off length;  $.150/.250$  is adequate.
8. Mounted core to be free to turn when in ejector plate assembly.
9. Center pin to be concentric with stripper bushing. Verify protrusion of pin through core and radius on tip of pin.
10. Positive collapse sleeve to travel freely through plates. Apply grease where indicated. Check for free movement when mold is at operating temperature.
11. When face of Collapsible Core segments shut-off against cavity (some parts with through holes), all cores must be ground to the same O.A.L. Normal tolerance of  $\pm .003$  is inadequate. Refer to Core Grinding Instructions. Clearance between end of core face and cavity to be  $.0005$  to  $.0010$ . Do not pre-load the core. Whenever the above condition exists, an early ejector plate return system must be used, or the cores will be destroyed.

**NOTE:** This applies only when the core seals off against the cavity. When the pin is seating against the cavity exercise care to avoid excessive pre-load of the pin. A  $.000$  to  $.0015$  interference is adequate.

12. Break all sharp corners.
13. The stripper shut-off diameter must be of the same diameter or preferably a larger diameter than any other diameter on the core.

**NOTE:** Due to the reduction in mold plate thicknesses as compared to the CC-200-PC Collapsible Core, no greater than a four-cavity CC-250-PC Core mold is recommended.

# D-M-E COLLAPSIBLE CORE

## CC 202 P.C. Core Dimensions

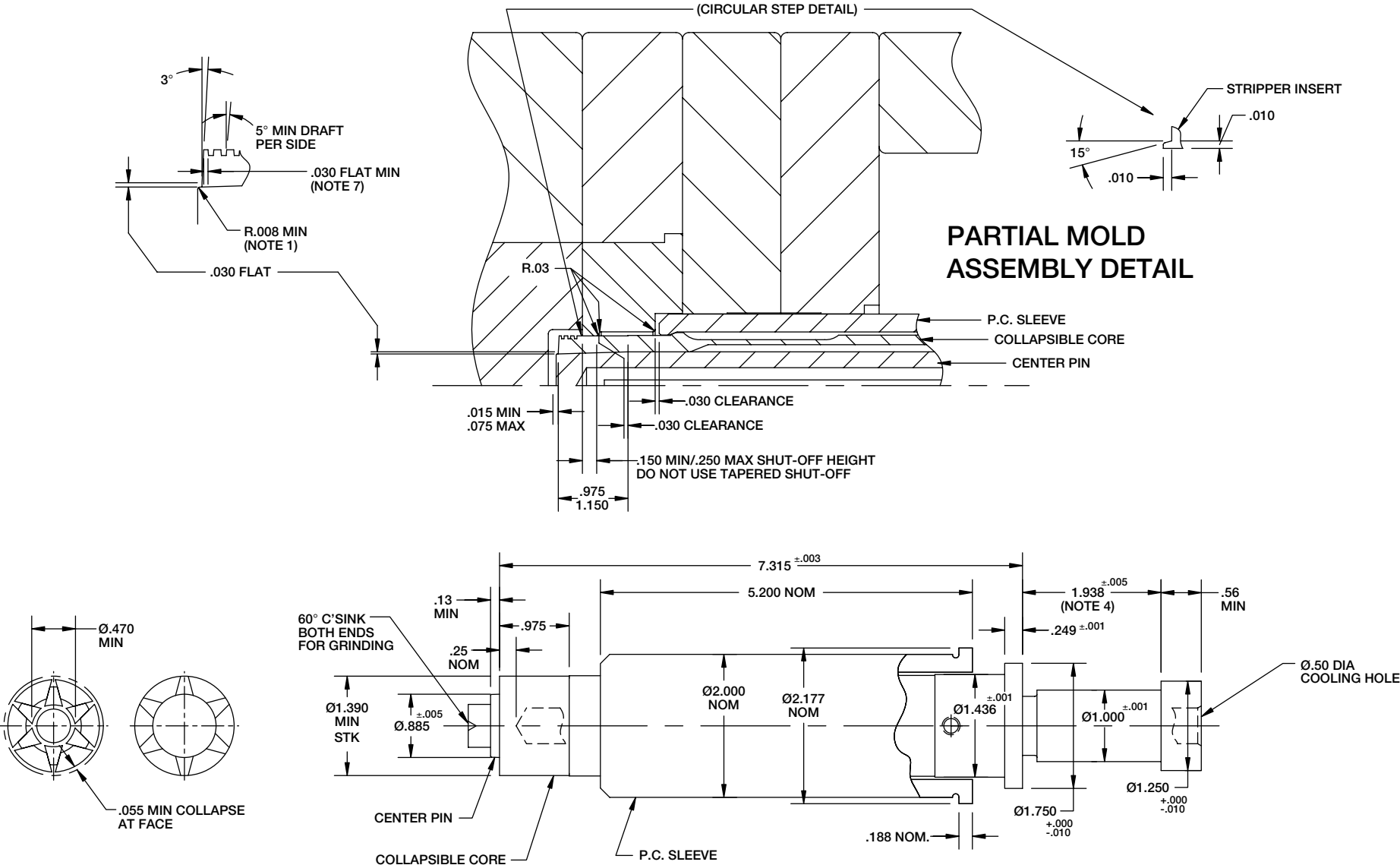

## D-M-E COLLAPSIBLE CORE

### CC 202 P.C. Core Dimensions (cont.)

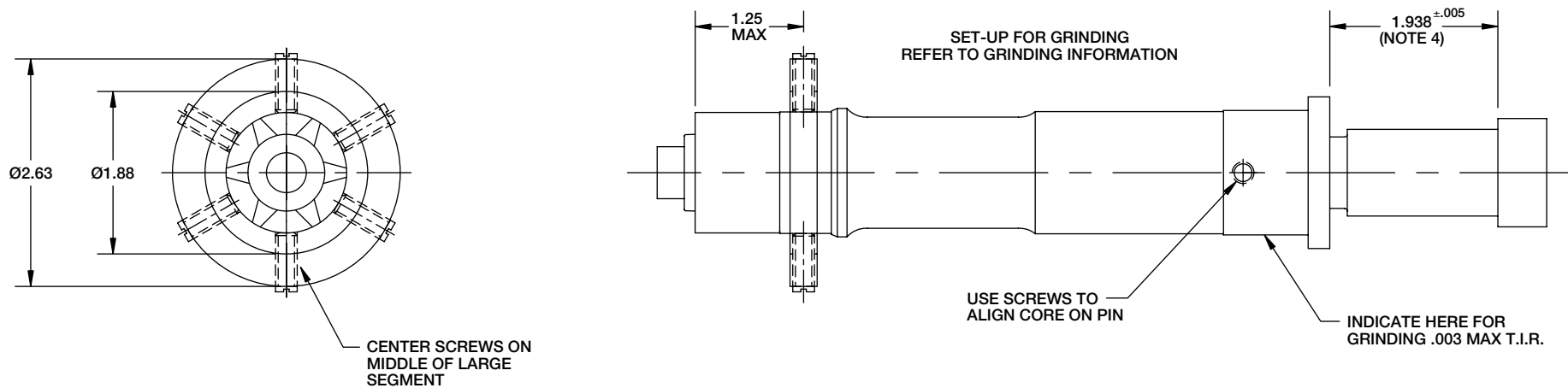

#### NOTES:

1. Center pin to project .015 minimum/.075 maximum above front face of Collapsible Core with .008 R minimum at corners. See suggested partial mold assembly view.
2. Both ends of center pin to be cut off after grinding contour on Collapsible Core before assembly in mold.
3. Minimum suggested I.D. of thread or undercut is 1.010-S to give minimum steel support between depth of undercut and center pin.
4. The  $1.938 \pm .005$  dimension must be held in mold assembly and core grinding.
5. Consult Grinding Instructions.
6.  $1/32$  radius essential on inside corners of stripper insert, especially where shut-off contacts Collapsible Core.
7. Thread must never be run out of face of core, leaving a knife-edge of material. For complete instructions, refer to Design Procedures.
8. Do not use center pin as a pilot into "A" half of mold.

Questions? Call D-M-E at 1-800-626-6653 (U.S.) • 1-800-387-6600 (Canada) • 32-15-215011 (Europe)





# D-M-E COLLAPSIBLE CORE

## CC 202 P.C. Mold Base Machining Dimensions (cont.)

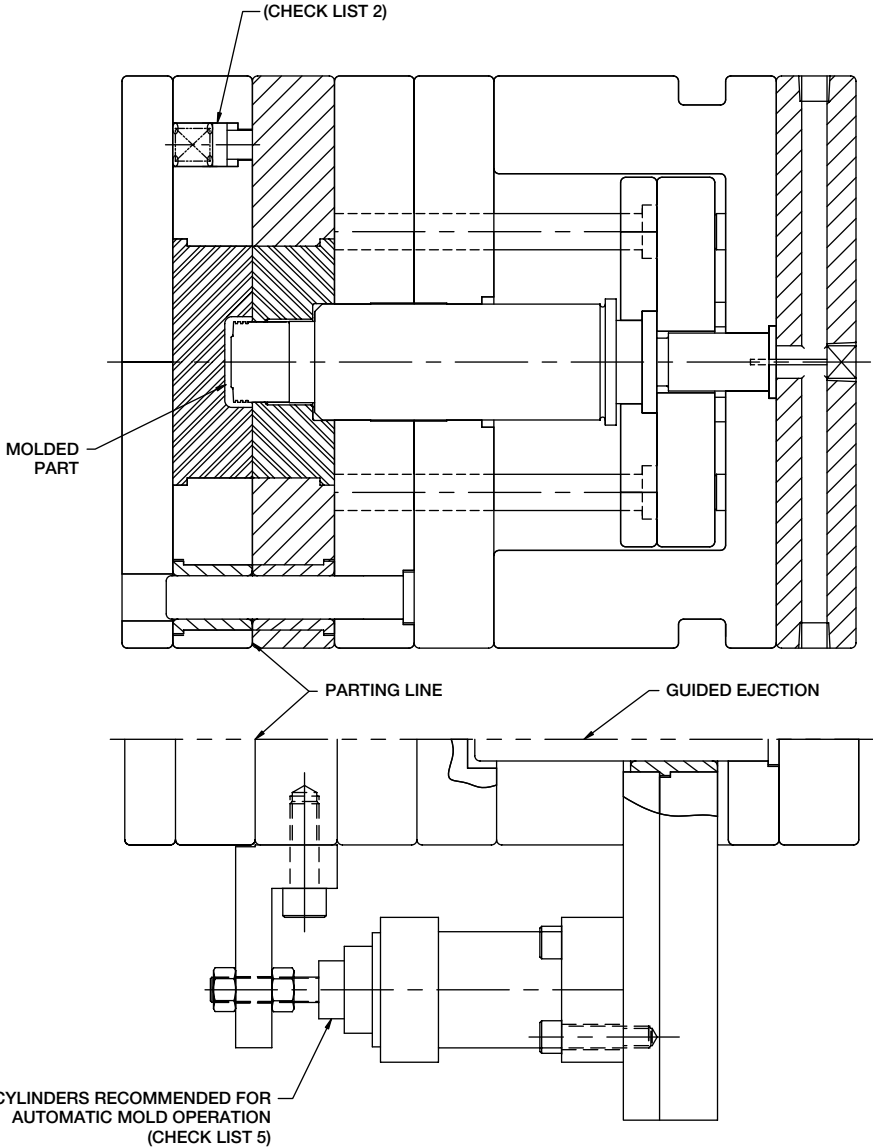

Questions? Call D-M-E at 1-800-626-6653 (U.S.) • 1-800-387-6600 (Canada) • 32-15-215011 (Europe)

## CC 202 P.C. Mold Base Machining Dimensions (cont.)

### Mold Design Check List

1. Use guided ejector plates and a support ring around center pin. Ejector plate, support rings and rest buttons must be ground to  $1.187 \pm .001$ .
  2. Use springs to assure first break at main parting line.
  3. Return pins to end under stripper plate.
  4. Ejector plate travel to specifications. Stamp dimension on edge of plate.
  5. Secondary stripper plate actuation to begin only after full ejector plate travel. Stripper plate must return fully before ejector plate begins to return (see Sequence Description).
  6. Good venting is essential, preferable to outside of mold.
  7. Clearance between core shut-off O.D. and stripper insert I.D. to be .0010/.0015 total. Measure core when installed in mold. No tapered shut-off permitted. Avoid excessive shut-off length; .150/.250 is adequate.
  8. Mounted core to be free to turn when in ejector plate assembly.
  9. Center pin to be concentric with stripper bushing. Verify protrusion of pin through core and radius on tip of pin.
  10. Positive collapse sleeve to travel freely through plates. Apply grease where indicated. Check for free movement when mold is at operating temperature.
  11. When face of Collapsible Core segments shut-off against cavity (some parts with through holes), all cores must be ground to the same O.A.L. Normal tolerance of  $\pm .003$  is inadequate. Refer to Core Grinding Instructions. Clearance between end of core face and cavity to be .0005 to .0010. Do not pre-load the core. Whenever the above condition exists, an early ejector plate return system must be used, or the cores will be destroyed.
- NOTE:** This applies only when the core seals off against the cavity. When the pin is seating against the cavity exercise care to avoid excessive pre-load of the pin. A .000 to .0015 interference is adequate.
12. Break all sharp corners.
  13. The stripper shut-off diameter must be of the same diameter or preferably a larger diameter than any other diameter on the core.

# D-M-E COLLAPSIBLE CORE

## CC 252 P.C. Core Dimensions

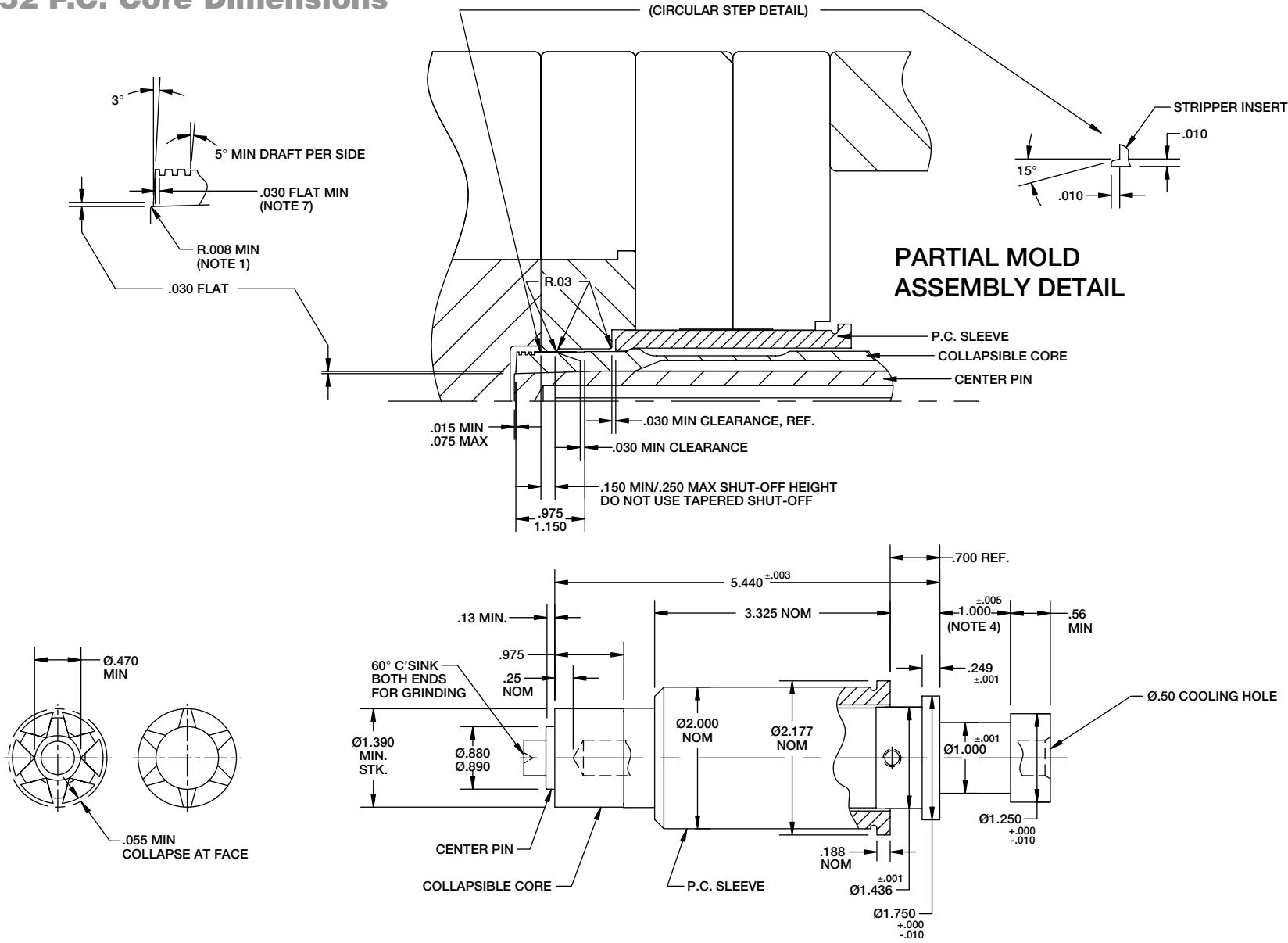

Questions? Call D-M-E at 1-800-626-6653 (U.S.) • 1-800-387-6600 (Canada) • 32-15-215011 (Europe)

## D-M-E COLLAPSIBLE CORE

### CC 252 P.C. Core Dimensions (cont.)

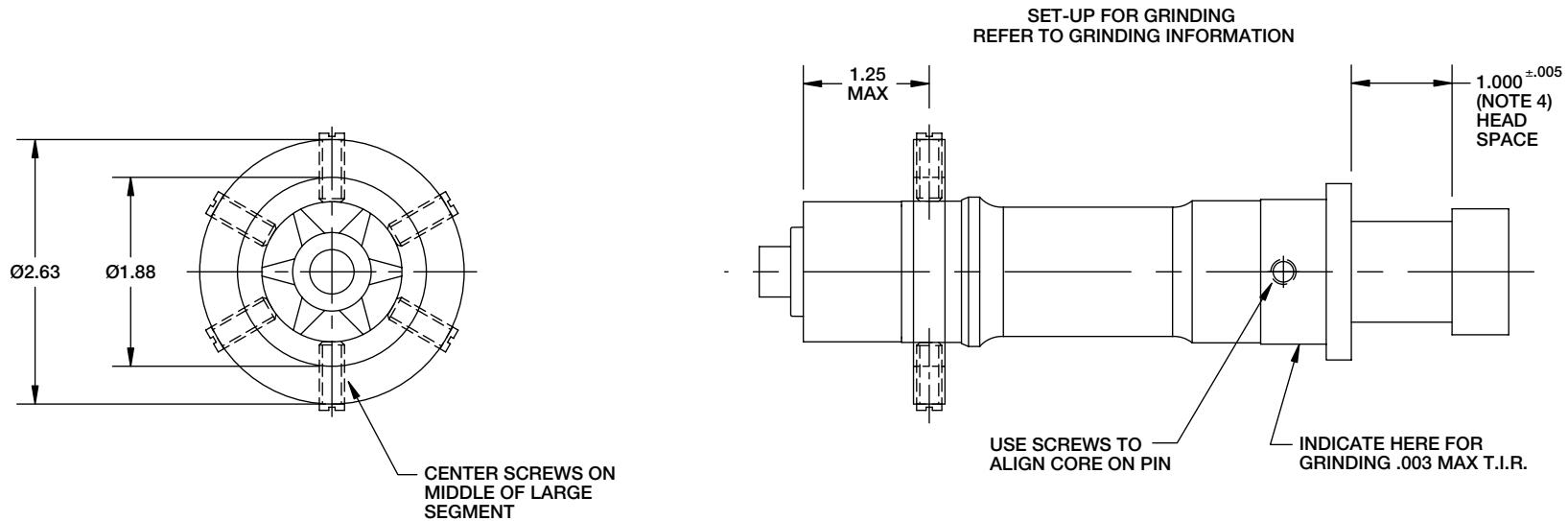

#### NOTES:

1. Center pin to project .015 minimum/.075 maximum above front face of Collapsible Core with .008 R minimum at corners. See suggested partial mold assembly view.
  2. Both ends of center pin to be cut off after grinding contour on Collapsible Core before assembly in mold.
  3. Minimum suggested I.D. of thread or undercut is .910-S to give minimum steel support between depth of undercut and center pin.
  4. The 1.000 ±.005 dimension must be held in mold assembly and core grinding.
  5. Consult Grinding Instructions.
  6. 1/32 radius essential on inside corners of stripper insert, especially where shut-off contacts Collapsible Core.
  7. Thread must never be run out of face of core, leaving a knife-edge of material. For complete instructions, refer to Design Procedures.
  8. Do not use center pin as a pilot into "A" half of mold.
- NOTE:** Due to the reduction in mold plate thicknesses as compared to the CC-202-PC Collapsible Core, no greater than a four-cavity CC-252-PC Core mold is recommended.

# D-M-E COLLAPSIBLE CORE

## CC 252 P.C. Mold Base Machining Dimensions

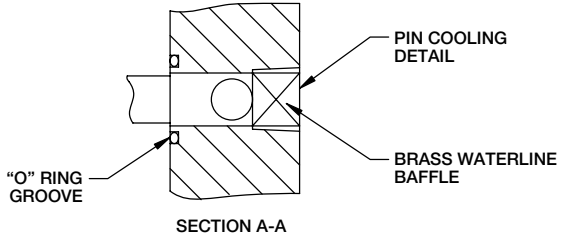
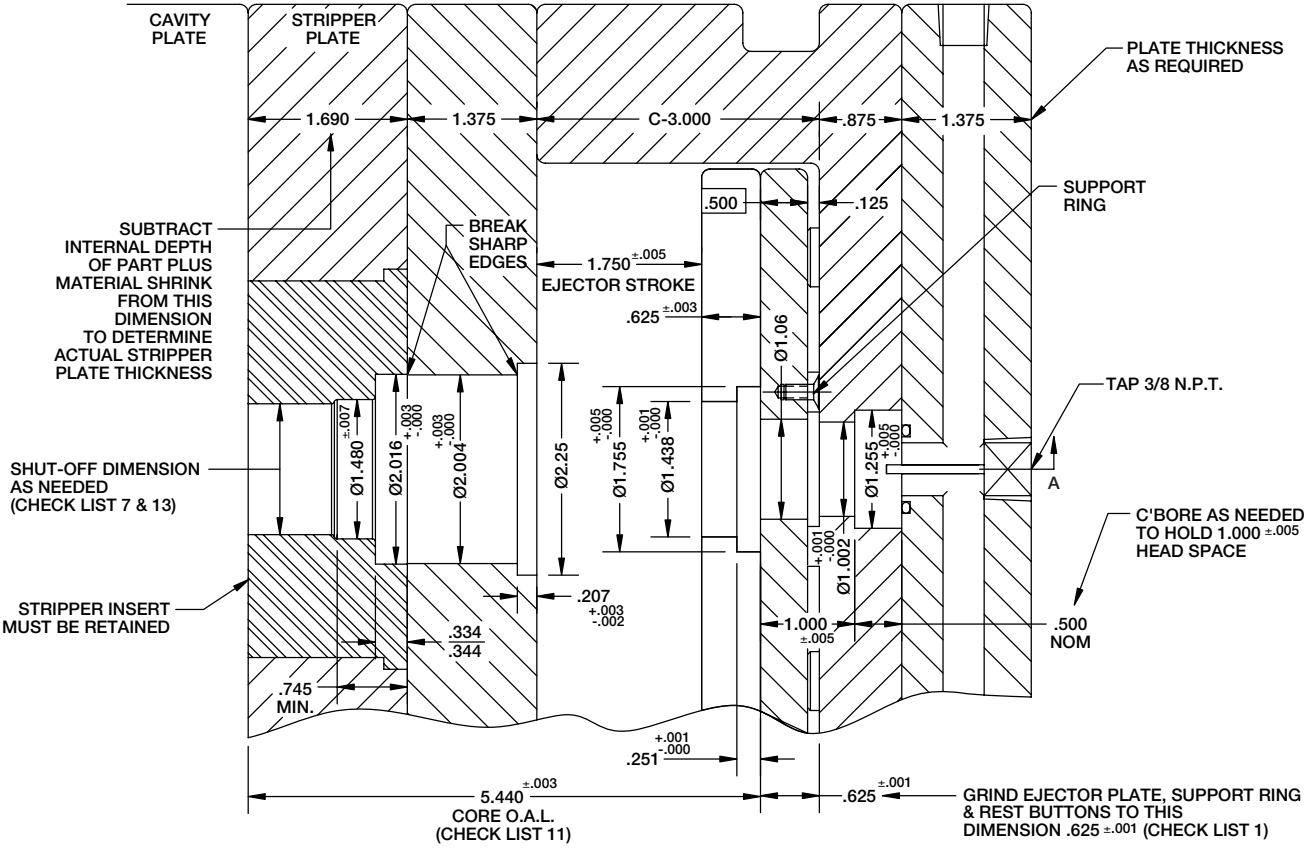

Questions? Call D-M-E at 1-800-626-6653 (U.S.) • 1-800-387-6600 (Canada) • 32-15-215011 (Europe)

# D-M-E COLLAPSIBLE CORE

## CC 252 P.C. Mold Base Machining Dimensions (cont.)

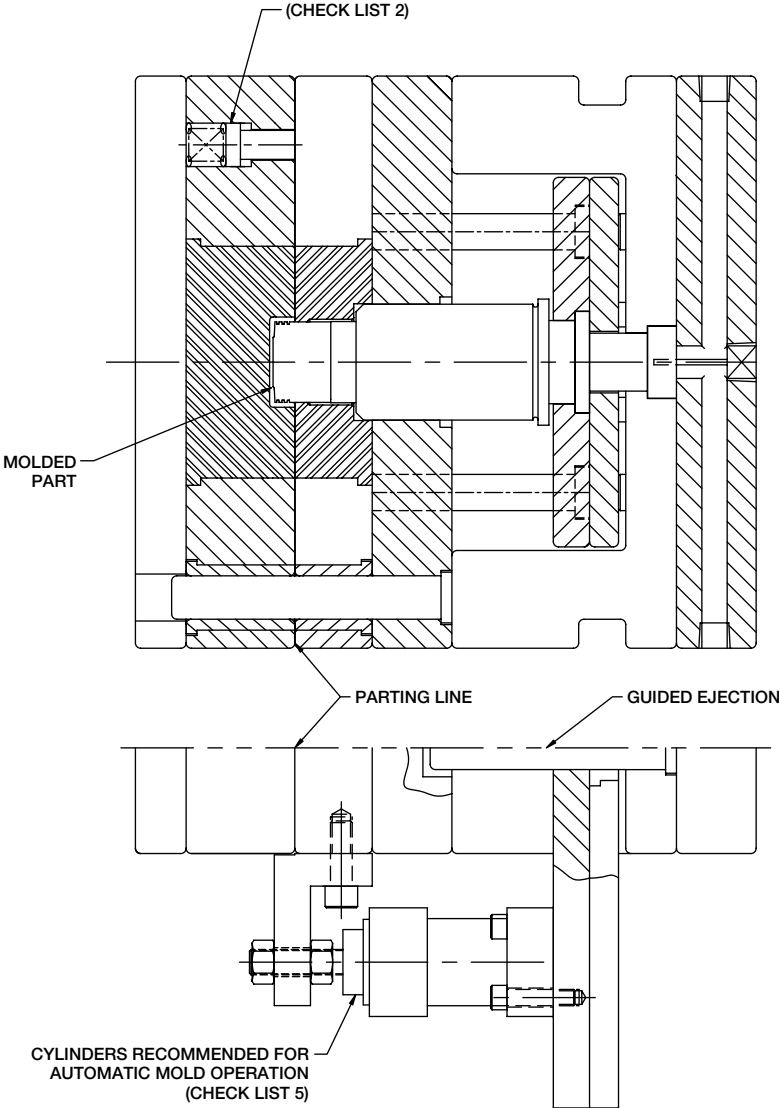

### CC 252 P.C. Mold Base Machining Dimensions (cont.)

#### Mold Design Check List

1. Use guided ejector plates and a support ring around center pin. Ejector plate, support rings and rest buttons must be ground to  $.625 \pm .001$ .
  2. Use springs to assure first break at main parting line.
  3. Return pins to end under stripper plate.
  4. Ejector plate travel to specifications. Stamp dimension on edge of plate.
  5. Secondary stripper plate actuation to begin only after full ejector plate travel. Stripper plate must return fully before ejector plate begins to return (see Sequence Description).
  6. Good venting is essential, preferable to outside of mold.
  7. Clearance between core shut-off O.D. and stripper insert I.D. to be  $.0010/.0015$  total. Measure core when installed in mold. No tapered shut-off permitted. Avoid excessive shut-off length;  $.150/.250$  is adequate.
  8. Mounted core to be free to turn when in ejector plate assembly.
  9. Center pin to be concentric with stripper bushing. Verify protrusion of pin through core and radius on tip of pin.
  10. Positive collapse sleeve to travel freely through plates. Apply grease where indicated. Check for free movement when mold is at operating temperature.
  11. When face of Collapsible Core segments shut-off against cavity (some parts with through holes), all cores must be ground to the same O.A.L. Normal tolerance of  $\pm .003$  is inadequate. Refer to Core Grinding Instructions. Clearance between end of core face and cavity to be  $.0005$  to  $.0010$ . Do not pre-load the core. Whenever the above condition exists, an early ejector plate return system must be used, or the cores will be destroyed.
- NOTE:** This applies only when the core seals off against the cavity. When the pin is seating against the cavity exercise care to avoid excessive pre-load of the pin. A  $.000$  to  $.0015$  interference is adequate.
12. Break all sharp corners.
  13. The stripper shut-off diameter must be of the same diameter or preferably a larger diameter than any other diameter on the core.
- NOTE:** Due to the reduction in mold plate thicknesses as compared to the CC-202-PC Collapsible Core, no greater than a four-cavity CC-252-PC Core mold is recommended.





## D-M-E COLLAPSIBLE CORE

### CC 302 P.C. Core Dimensions (cont.)

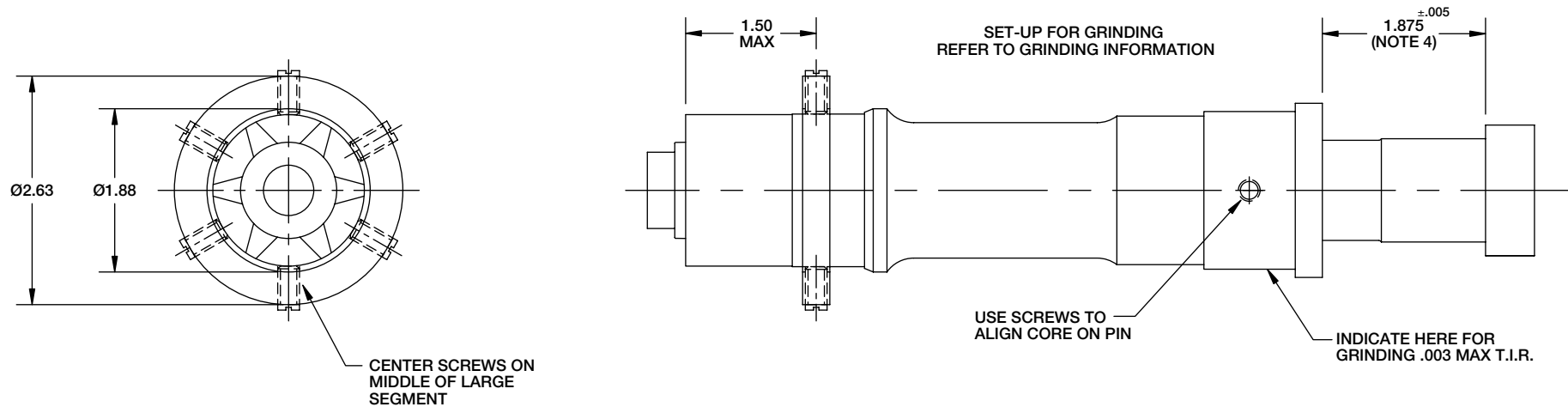

#### NOTES:

1. Center pin to project .020 minimum/.075 maximum above front face of Collapsible Core with .008 R minimum at corners. See suggested partial mold assembly view.
2. Both ends of center pin to be cut off after grinding contour on Collapsible Core before assembly in mold.
3. Minimum suggested I.D. of thread or undercut is 1.270-S to give minimum steel support between depth of undercut and center pin.
4. The  $1.875 \pm .005$  dimension must be held in mold assembly and core grinding.
5. Consult Grinding Instructions.
6.  $1/32$  radius essential on inside corners of stripper insert, especially where shut-off contacts Collapsible Core.
7. Thread must never be run out of face of core, leaving a knife-edge of material. For complete instructions, refer to Design Procedures.
8. Do not use center pin as a pilot into "A" half of mold.

Questions? Call D-M-E at 1-800-626-6653 (U.S.) • 1-800-387-6600 (Canada) • 32-15-215011 (Europe)

# D-M-E COLLAPSIBLE CORE

## CC 302 P.C. Mold Base Machining Dimensions

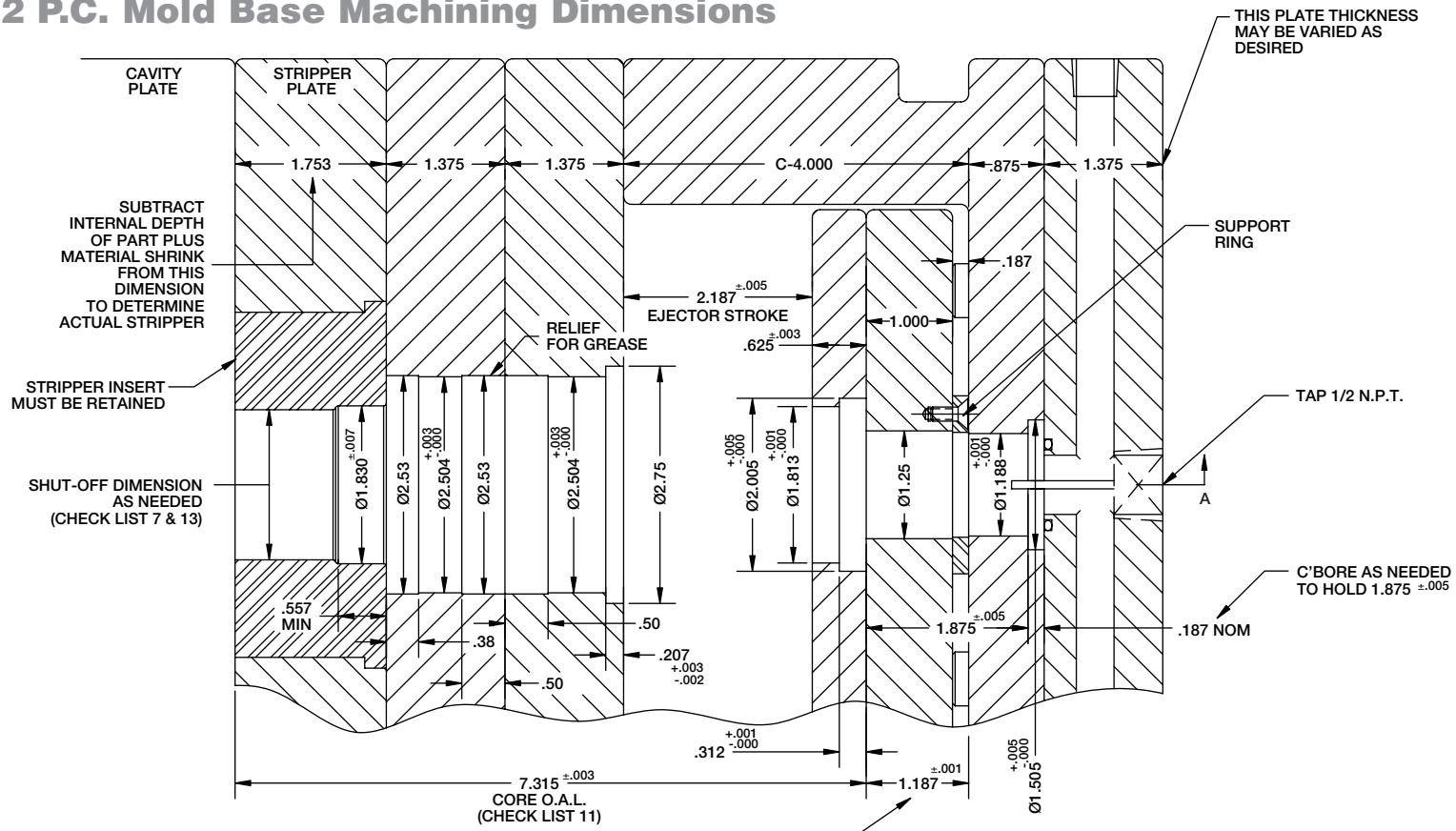

GRIND EJECTOR PLATE, SUPPORT RING, & REST BUTTONS TO THIS DIMENSION 1.187 ±.001 (CHECK LIST 1)

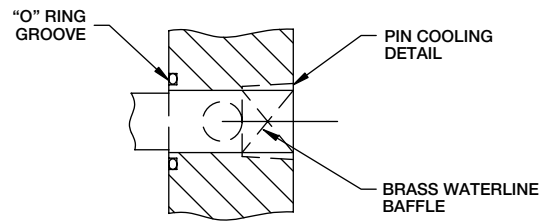

SECTION A-A

D-M-E COLLAPSIBLE CORE

CC 302 P.C. Mold Base Machining Dimensions (cont.)

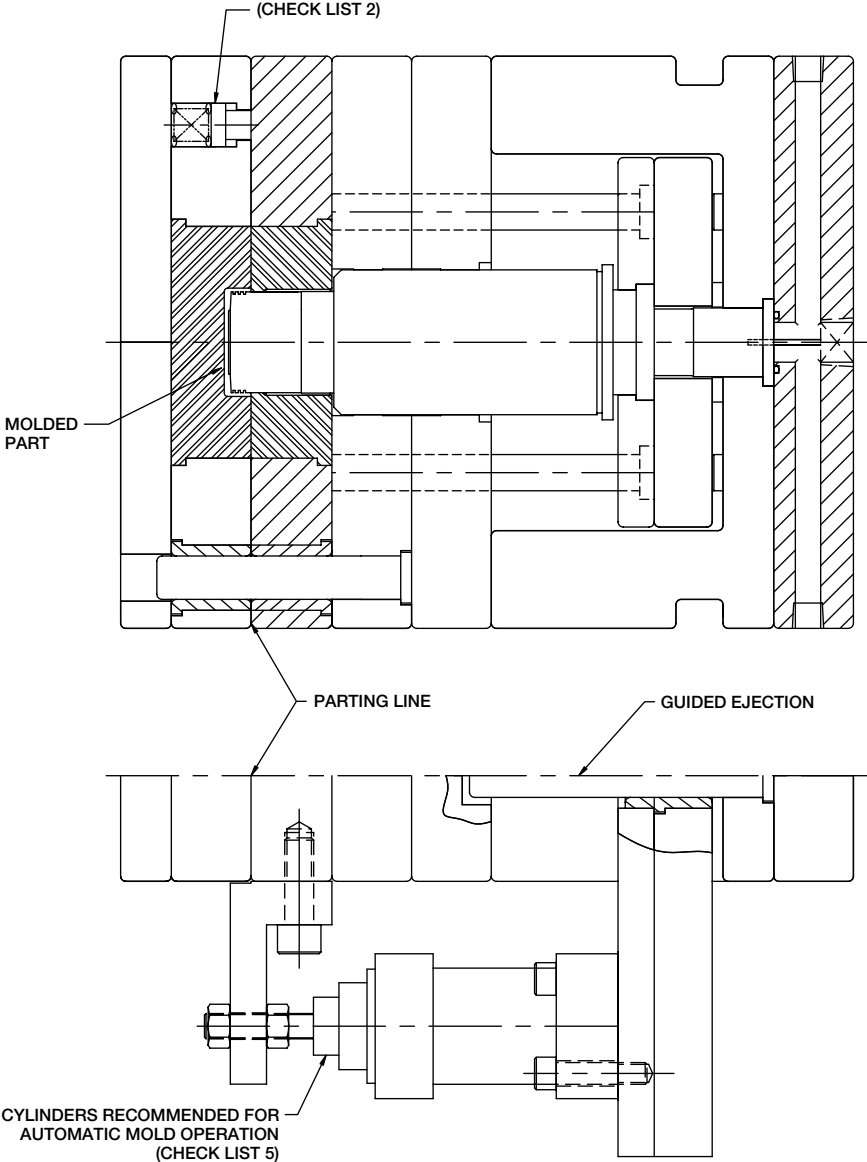

Questions? Call D-M-E at 1-800-626-6653 (U.S.) • 1-800-387-6600 (Canada) • 32-15-215011 (Europe)

### CC 302 P.C. Mold Base Machining Dimensions (cont.)

#### Mold Design Check List

1. Use guided ejector plates and a support ring around center pin. Ejector plate, support rings and rest buttons must be ground to  $1.187 \pm .001$ .
  2. Use springs to assure first break at main parting line.
  3. Return pins to end under stripper plate.
  4. Ejector plate travel to specifications. Stamp dimension on edge of plate.
  5. Secondary stripper plate actuation to begin only after full ejector plate travel. Stripper plate must return fully before ejector plate begins to return (see Sequence Description).
  6. Good venting is essential, preferable to outside of mold.
  7. Clearance between core shut-off O.D. and stripper insert I.D. to be .0010/.0015 total. Measure core when installed in mold. No tapered shut-off permitted. Avoid excessive shut-off length; .150/.250 is adequate.
  8. Mounted core to be free to turn when in ejector plate assembly.
  9. Center pin to be concentric with stripper bushing. Verify protrusion of pin through core and radius on tip of pin.
  10. Positive collapse sleeve to travel freely through plates. Apply grease where indicated. Check for free movement when mold is at operating temperature.
  11. When face of Collapsible Core segments shut-off against cavity (some parts with through holes), all cores must be ground to the same O.A.L. Normal tolerance of  $\pm .003$  is inadequate. Refer to Core Grinding Instructions. Clearance between end of core face and cavity to be .0005 to .0010. Do not pre-load the core. Whenever the above condition exists, an early ejector plate return system must be used, or the cores will be destroyed.
- NOTE:** This applies only when the core seals off against the cavity. When the pin is seating against the cavity exercise care to avoid excessive pre-load of the pin. A .000 to .0015 interference is adequate.
12. Break all sharp corners.
  13. The stripper shut-off diameter must be of the same diameter or preferably a larger diameter than any other diameter on the core.

# D-M-E COLLAPSIBLE CORE

## CC 352 P.C. Core Dimensions

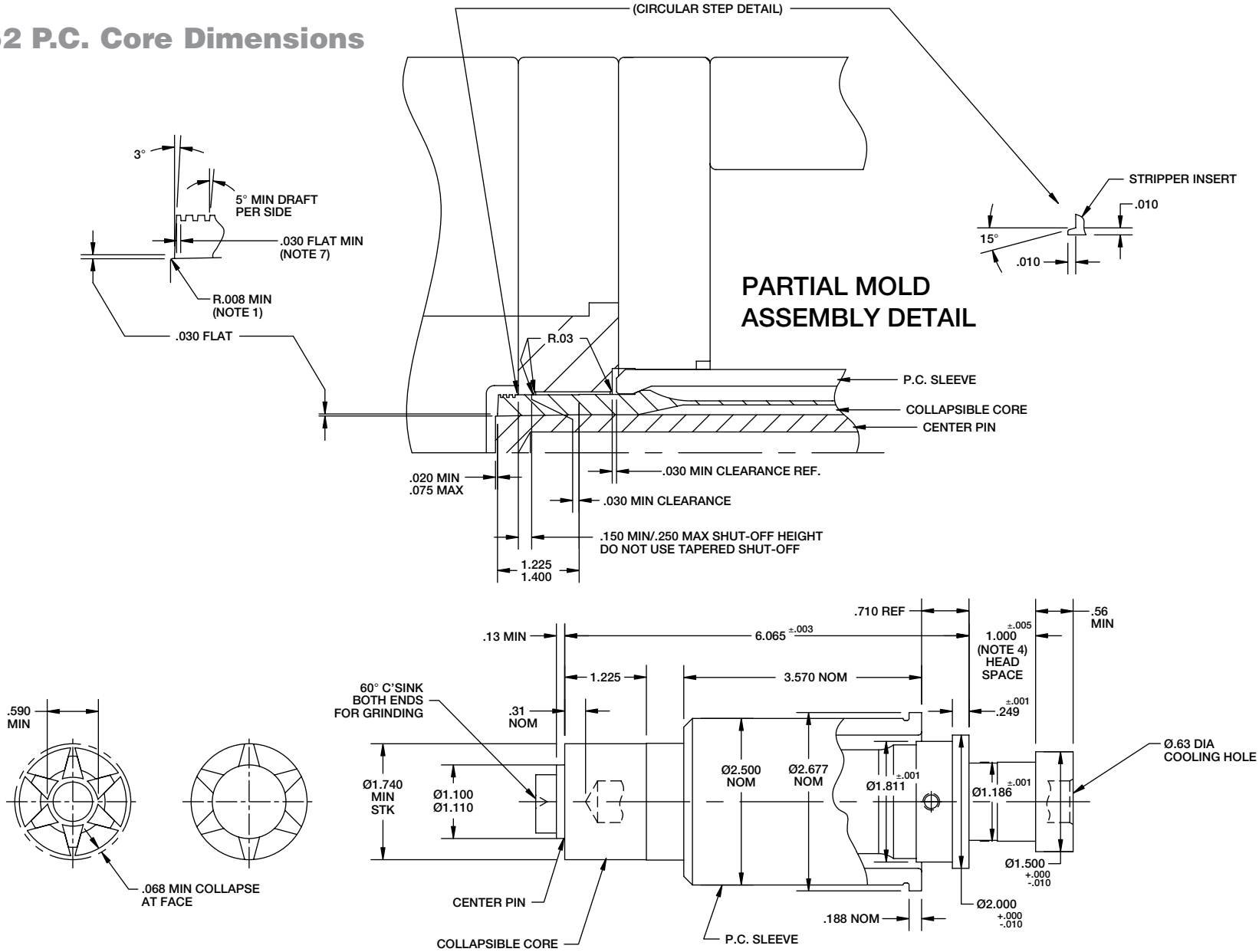

Questions? Call D-M-E at 1-800-626-6653 (U.S.) • 1-800-387-6600 (Canada) • 32-15-215011 (Europe)

# D-M-E COLLAPSIBLE CORE

## CC 352 P.C. Core Dimensions (cont.)

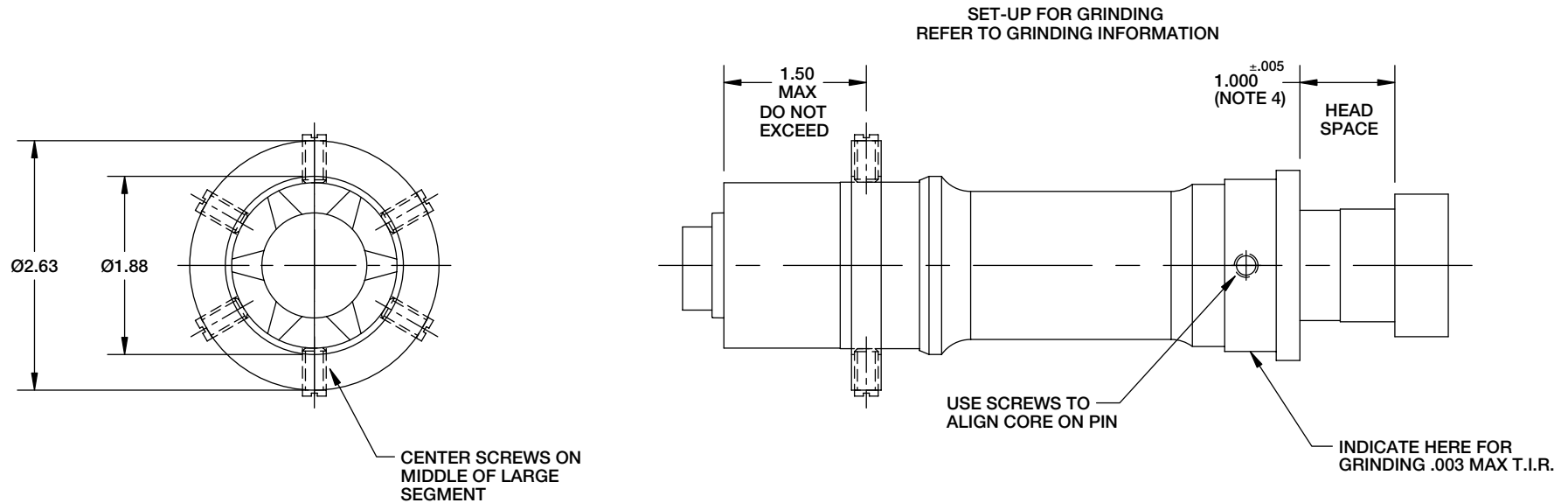

### NOTES:

1. Center pin to project .020 minimum/.075 maximum above front face of Collapsible Core with .008 R minimum at corners. See suggested partial mold assembly view.
  2. Both ends of center pin to be cut off after grinding contour on Collapsible Core before assembly in mold.
  3. Minimum suggested I.D. of thread or undercut is 1.270-S to give minimum steel support between depth of undercut and center pin.
  4. The 1.000 ±.005 dimension must be held in mold assembly and core grinding.
  5. Consult Grinding Instructions.
  6. 1/32 radius essential on inside corners of stripper insert, especially where shut-off contacts Collapsible Core.
  7. Thread must never be run out of face of core, leaving a knife-edge of material. For complete instructions, refer to Design Procedures.
  8. Do not use center pin as a pilot into "A" half of mold.
- NOTE:** Due to the reduction in mold plate thicknesses as compared to the CC-302-PC Collapsible Core, no greater than a four-cavity CC-352-PC Core mold is recommended.

# D-M-E COLLAPSIBLE CORE

## CC 352 P.C. Mold Base Machining Dimensions

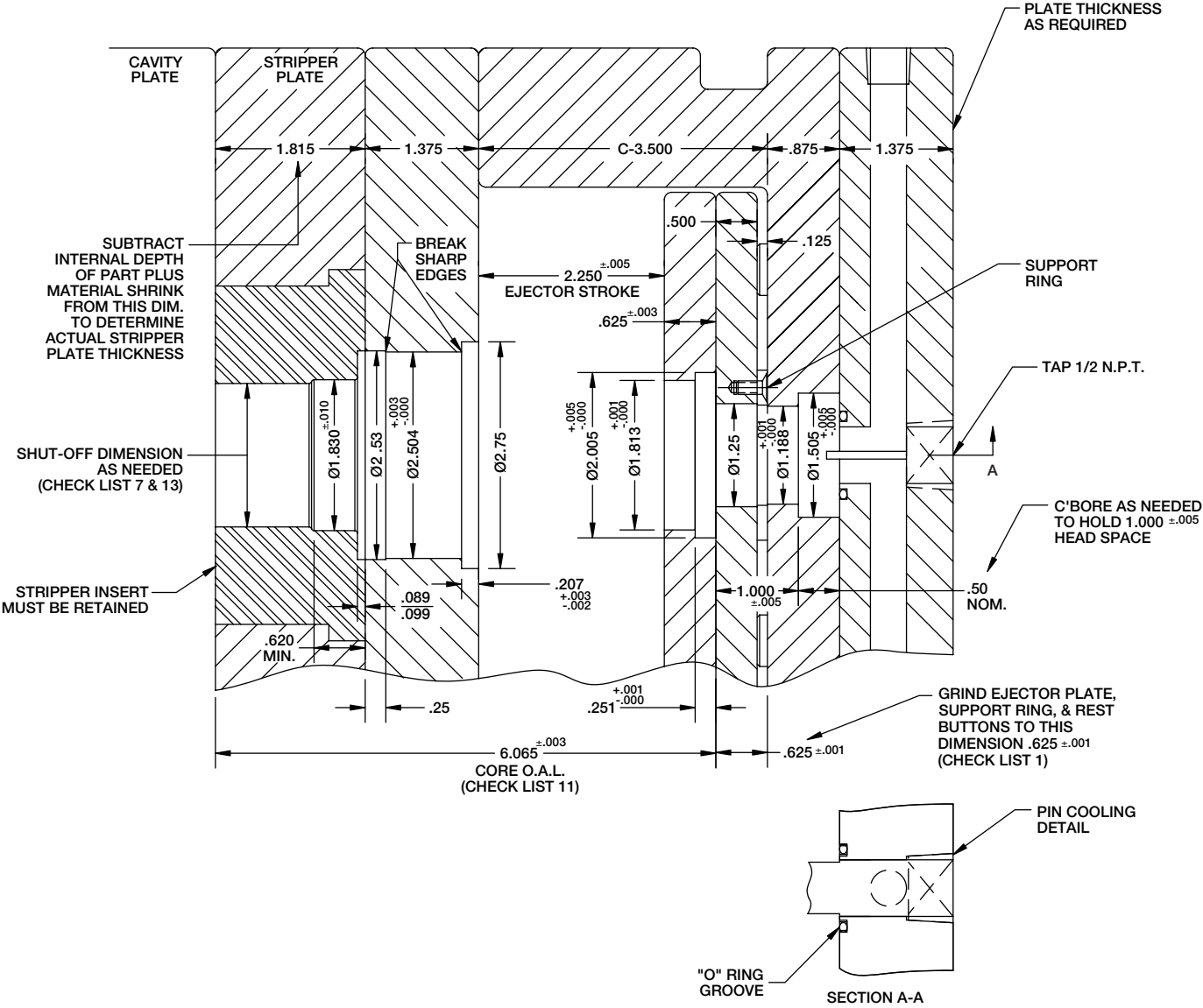

Questions? Call D-M-E at 1-800-626-6653 (U.S.) • 1-800-387-6600 (Canada) • 32-15-215011 (Europe)

# D-M-E COLLAPSIBLE CORE

## CC 352 P.C. Mold Base Machining Dimensions (cont.)

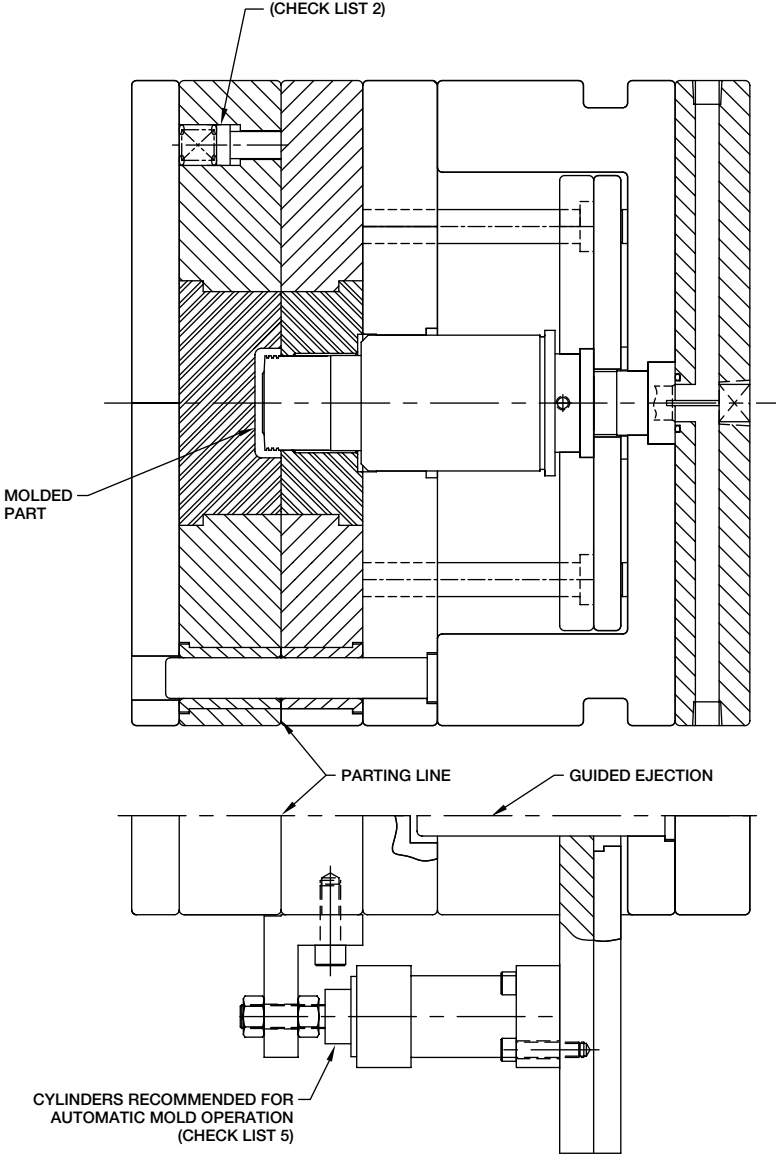



### CC 352 P.C. Mold Base Machining Dimensions (cont.)

#### Mold Design Check List

1. Use guided ejector plates and a support ring around center pin. Ejector plate, support rings and rest buttons must be ground to  $.625 \pm .001$ .
2. Use springs to assure first break at main parting line.
3. Return pins to end under stripper plate.
4. Ejector plate travel to specifications. Stamp dimension on edge of plate.
5. Secondary stripper plate actuation to begin only after full ejector plate travel. Stripper plate must return fully before ejector plate begins to return (see Sequence Description).
6. Good venting is essential, preferable to outside of mold.
7. Clearance between core shut-off O.D. and stripper insert I.D. to be  $.0010/.0015$  total. Measure core when installed in mold. No tapered shut-off permitted. Avoid excessive shut-off length;  $.150/.250$  is adequate.
8. Mounted core to be free to turn when in ejector plate assembly.
9. Center pin to be concentric with stripper bushing. Verify protrusion of pin through core and radius on tip of pin.
10. Positive collapse sleeve to travel freely through plates. Apply grease where indicated. Check for free movement when mold is at operating temperature.
11. When face of Collapsible Core segments shut-off against cavity (some parts with through holes), all cores must be ground to the same O.A.L. Normal tolerance of  $\pm .003$  is inadequate. Refer to Core Grinding Instructions. Clearance between end of core face and cavity to be  $.0005$  to  $.0010$ . Do not pre-load the core. Whenever the above condition exists, an early ejector plate return system must be used, or the cores will be destroyed.

**NOTE:** This applies only when the core seals off against the cavity. When the pin is seating against the cavity exercise care to avoid excessive pre-load of the pin. A  $.000$  to  $.0015$  interference is adequate.

12. Break all sharp corners.
13. The stripper shut-off diameter must be of the same diameter or preferably a larger diameter than any other diameter on the core.

**NOTE:** Due to the reduction in mold plate thicknesses as compared to the CC-302-PC Collapsible Core, no greater than a four-cavity CC-352-PC Core mold is recommended.

# D-M-E COLLAPSIBLE CORE

## CC 402 P.C. Core Dimensions

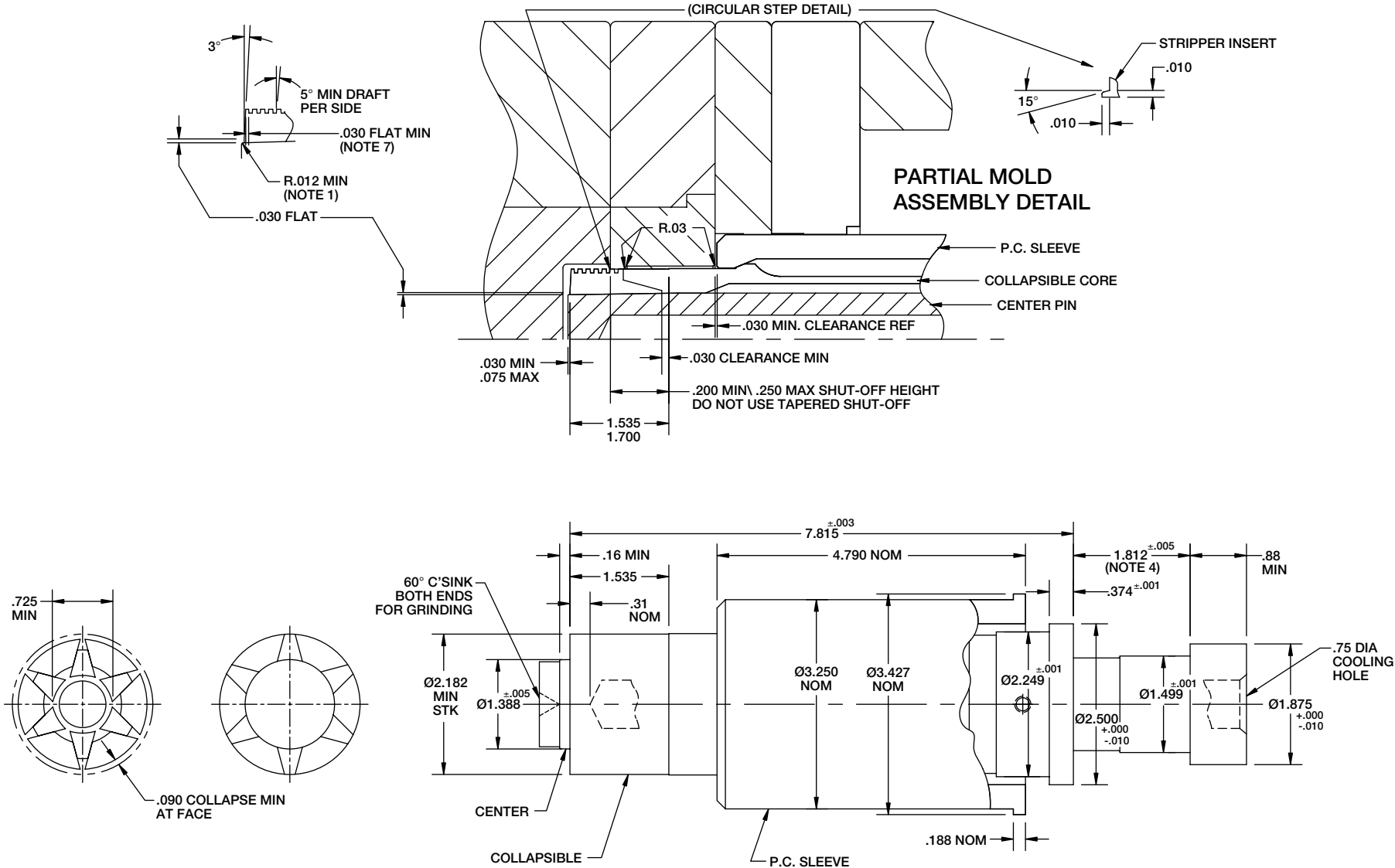

## D-M-E COLLAPSIBLE CORE

### CC 402 P.C. Core Dimensions (cont.)

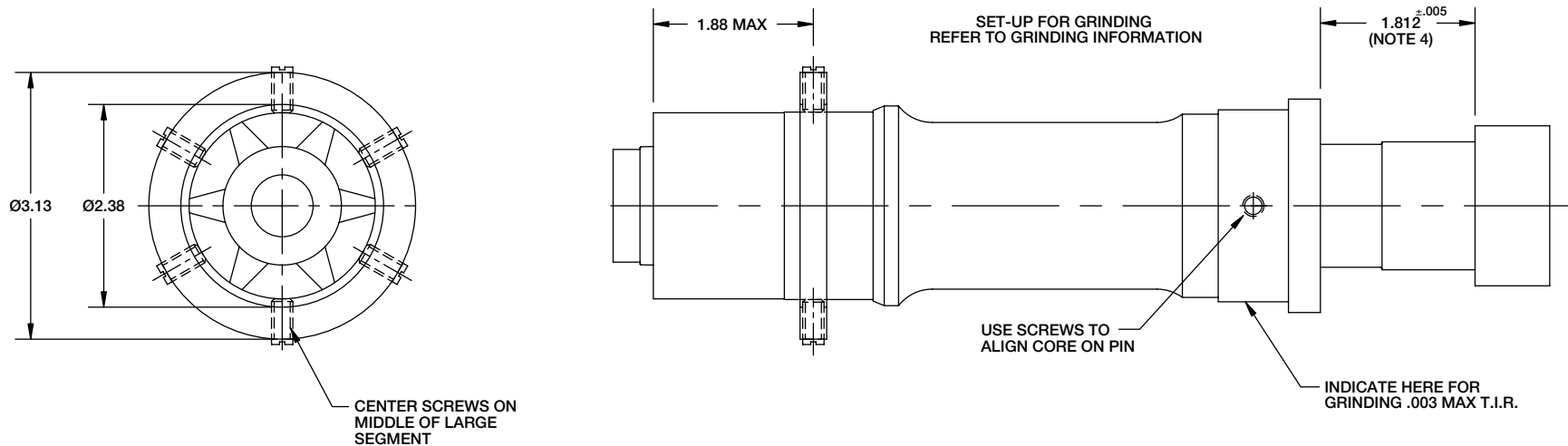

#### NOTES:

1. Center pin to project .030 minimum/.075 maximum above front face of Collapsible Core with .012 R minimum at corners. See suggested partial mold assembly view.
2. Both ends of center pin to be cut off after grinding contour on Collapsible Core before assembly in mold.
3. Minimum suggested I.D. of thread or undercut is 1.593-S to give minimum steel support between depth of undercut and center pin.
4. The 1.812 ±.005 dimension must be held in mold assembly and core grinding.
5. Consult Grinding Instructions.
6. 1/32 radius essential on inside corners of stripper insert, especially where shut-off contacts Collapsible Core.
7. Thread must never be run out of face of core, leaving a knife-edge of material. For complete instructions, refer to Design Procedures.
8. Do not use center pin as a pilot into "A" half of mold.

Questions? Call D-M-E at 1-800-626-6653 (U.S.) • 1-800-387-6600 (Canada) • 32-15-215011 (Europe)



D-M-E COLLAPSIBLE CORE

CC 402 P.C. Mold Base Machining Dimensions (cont.)

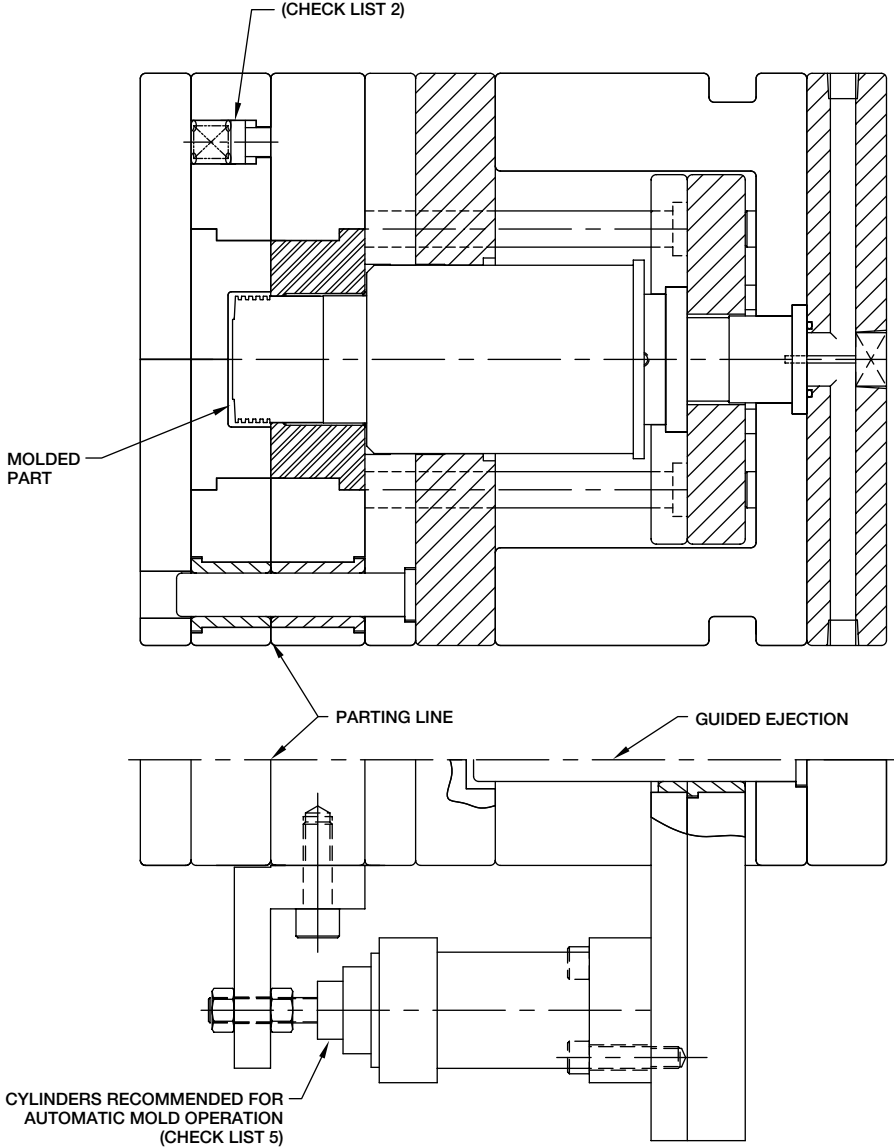

Questions? Call D-M-E at 1-800-626-6653 (U.S.) • 1-800-387-6600 (Canada) • 32-15-215011 (Europe)

### CC 402 P.C. Mold Base Machining Dimensions (cont.)

#### Mold Design Check List

1. Use guided ejector plates and a support ring around center pin. Ejector plate, support rings and rest buttons must be ground to  $1.187 \pm .001$ .
  2. Use springs to assure first break at main parting line.
  3. Return pins to end under stripper plate.
  4. Ejector plate travel to specifications. Stamp dimension on edge of plate.
  5. Secondary stripper plate actuation to begin only after full ejector plate travel. Stripper plate must return fully before ejector plate begins to return (see Sequence Description).
  6. Good venting is essential, preferable to outside of mold.
  7. Clearance between core shut-off O.D. and stripper insert I.D. to be .0010/.0015 total. Measure core when installed in mold. No tapered shut-off permitted. Avoid excessive shut-off length; .150/.250 is adequate.
  8. Mounted core to be free to turn when in ejector plate assembly.
  9. Center pin to be concentric with stripper bushing. Verify protrusion of pin through core and radius on tip of pin.
  10. Positive collapse sleeve to travel freely through plates. Apply grease where indicated. Check for free movement when mold is at operating temperature.
  11. When face of Collapsible Core segments shut-off against cavity (some parts with through holes), all cores must be ground to the same O.A.L. Normal tolerance of  $\pm .003$  is inadequate. Refer to Core Grinding Instructions. Clearance between end of core face and cavity to be .0005 to .0010. Do not pre-load the core. Whenever the above condition exists, an early ejector plate return system must be used, or the cores will be destroyed.
- NOTE:** This applies only when the core seals off against the cavity. When the pin is seating against the cavity exercise care to avoid excessive pre-load of the pin. A .000 to .0015 interference is adequate.
12. Break all sharp corners.
  13. The stripper shut-off diameter must be of the same diameter or preferably a larger diameter than any other diameter on the core.

# D-M-E COLLAPSIBLE CORE

## CC 502 P.C. Core Dimensions

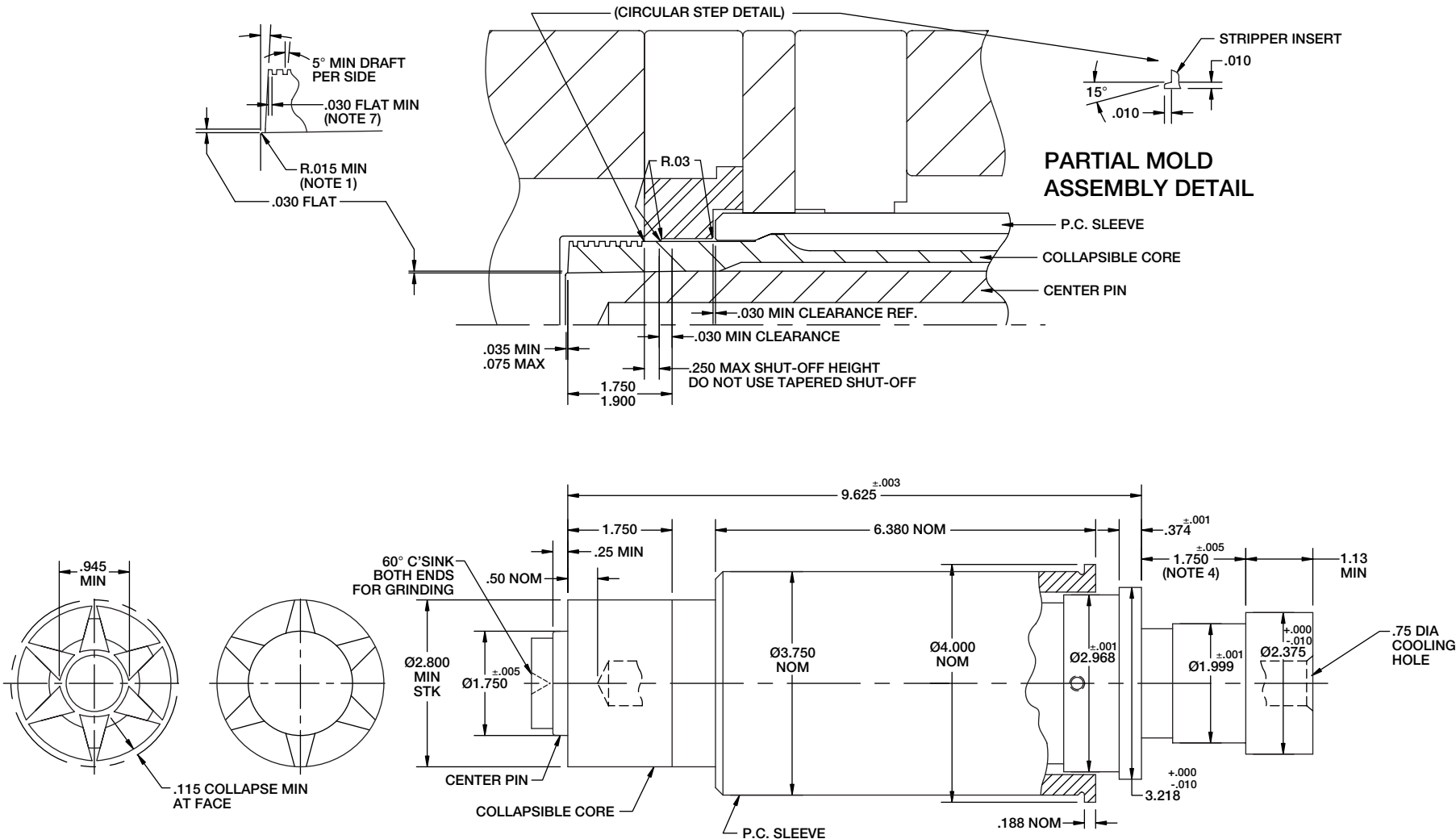

Questions? Call D-M-E at 1-800-626-6653 (U.S.) • 1-800-387-6600 (Canada) • 32-15-215011 (Europe)

# D-M-E COLLAPSIBLE CORE

## CC 502 P.C. Core Dimensions (cont.)

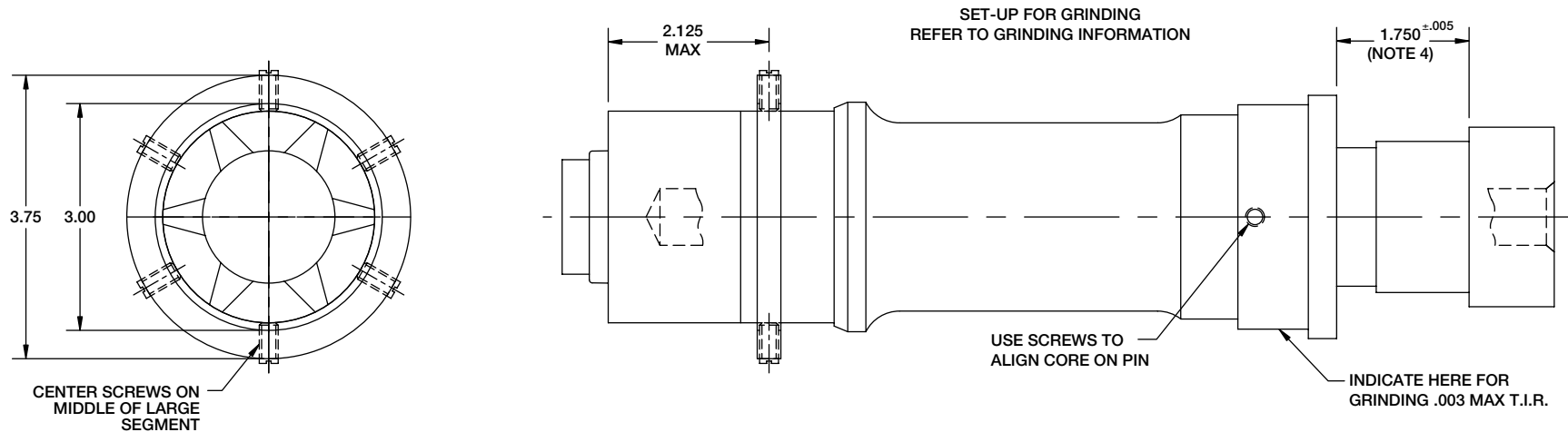

### NOTES:

1. Center pin to project .035 minimum/.075 maximum above front face of Collapsible Core with .015 R minimum at corners. See suggested partial mold assembly view.
2. Both ends of center pin to be cut off after grinding contour on Collapsible Core before assembly in mold.
3. Minimum suggested I.D. of thread or undercut is 2.060-S to give minimum steel support between depth of undercut and center pin.
4. The 1.750 ±.005 dimension must be held in mold assembly and core grinding.
5. Consult Grinding Instructions.
6. 1/32 radius essential on inside corners of stripper insert, especially where shut-off contacts Collapsible Core.
7. Thread must never be run out of face of core, leaving a knife-edge of material. For complete instructions, refer to Design Procedures.
8. Do not use center pin as a pilot into "A" half of mold.



# D-M-E COLLAPSIBLE CORE

## CC 502 P.C. Mold Base Machining Dimensions

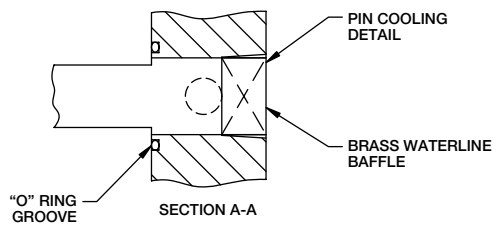
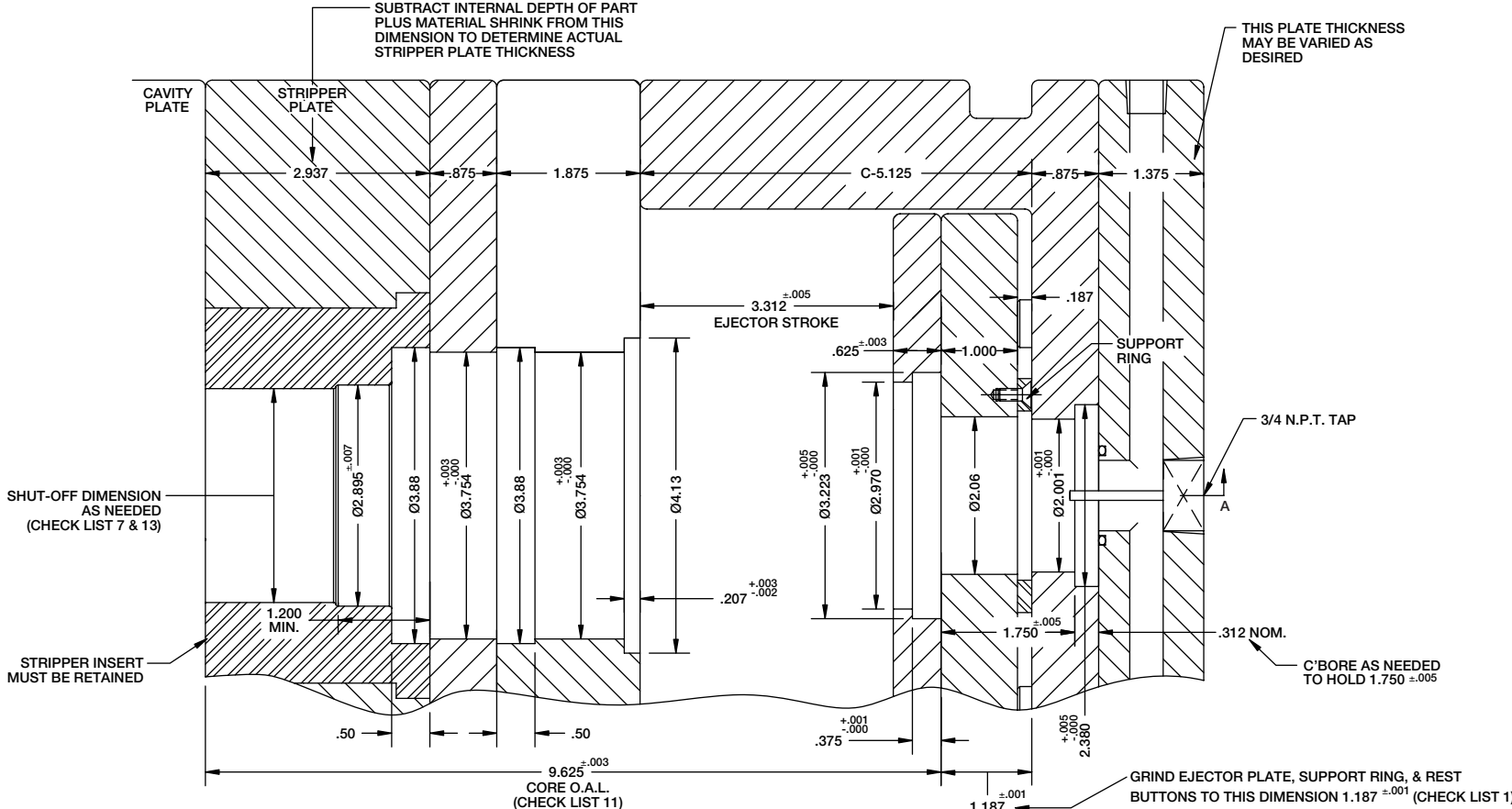

Questions? Call D-M-E at 1-800-626-6653 (U.S.) • 1-800-387-6600 (Canada) • 32-15-215011 (Europe)

# D-M-E COLLAPSIBLE CORE

## CC 502 P.C. Mold Base Machining Dimensions (cont.)

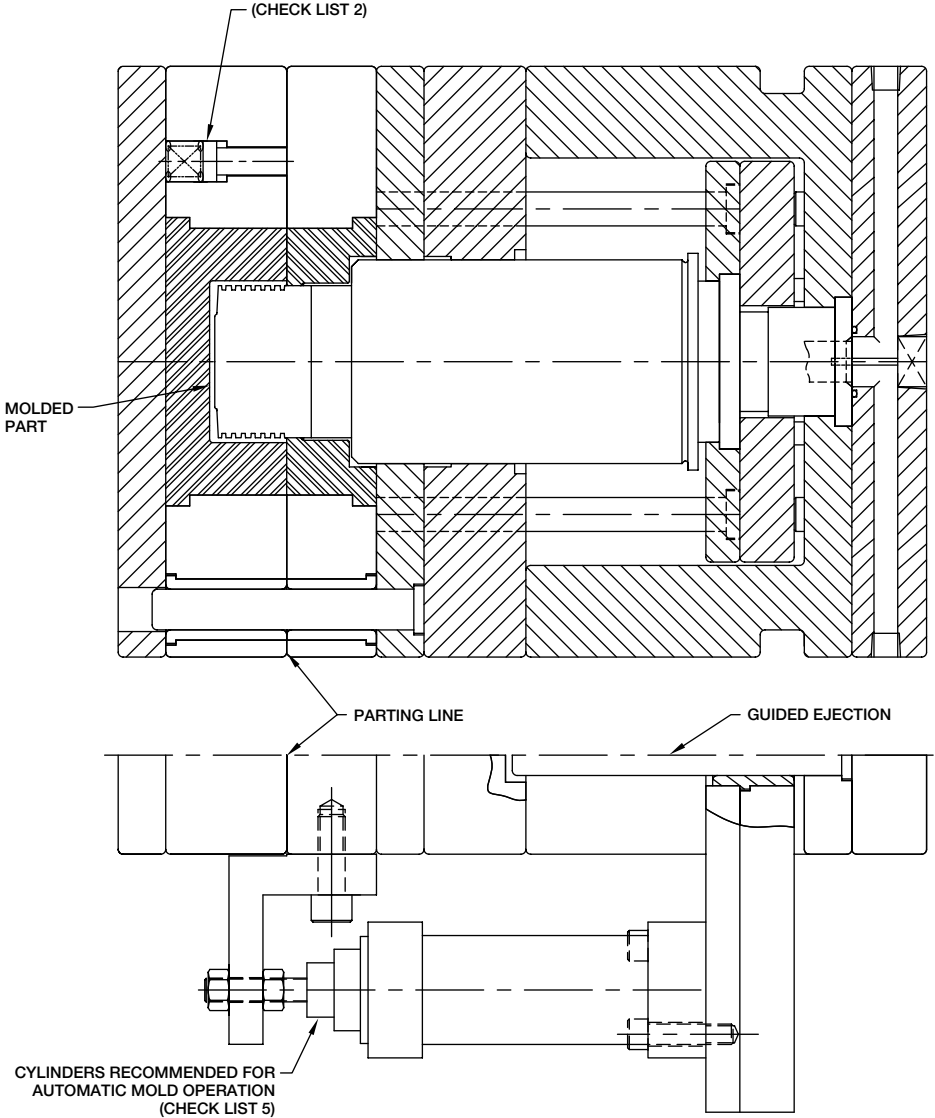

### CC 502 P.C. Mold Base Machining Dimensions (cont.)

#### Mold Design Check List

1. Use guided ejector plates and a support ring around center pin. Ejector plate, support rings and rest buttons must be ground to  $1.187 \pm .001$ .
  2. Use springs to assure first break at main parting line.
  3. Return pins to end under stripper plate.
  4. Ejector plate travel to specifications. Stamp dimension on edge of plate.
  5. Secondary stripper plate actuation to begin only after full ejector plate travel. Stripper plate must return fully before ejector plate begins to return (see Sequence Description).
  6. Good venting is essential, preferable to outside of mold.
  7. Clearance between core shut-off O.D. and stripper insert I.D. to be .0010/.0015 total. Measure core when installed in mold. No tapered shut-off permitted. Avoid excessive shut-off length; .150/.250 is adequate.
  8. Mounted core to be free to turn when in ejector plate assembly.
  9. Center pin to be concentric with stripper bushing. Verify protrusion of pin through core and radius on tip of pin.
  10. Positive collapse sleeve to travel freely through plates. Apply grease where indicated. Check for free movement when mold is at operating temperature.
  11. When face of Collapsible Core segments shut-off against cavity (some parts with through holes), all cores must be ground to the same O.A.L. Normal tolerance of  $\pm .003$  is inadequate. Refer to Core Grinding Instructions. Clearance between end of core face and cavity to be .0005 to .0010. Do not pre-load the core. Whenever the above condition exists, an early ejector plate return system must be used, or the cores will be destroyed.
- NOTE:** This applies only when the core seals off against the cavity. When the pin is seating against the cavity exercise care to avoid excessive pre-load of the pin. A .000 to .0015 interference is adequate.
12. Break all sharp corners.
  13. The stripper shut-off diameter must be of the same diameter or preferably a larger diameter than any other diameter on the core.

# D-M-E COLLAPSIBLE CORE

## CC 602 P.C. Core Dimensions

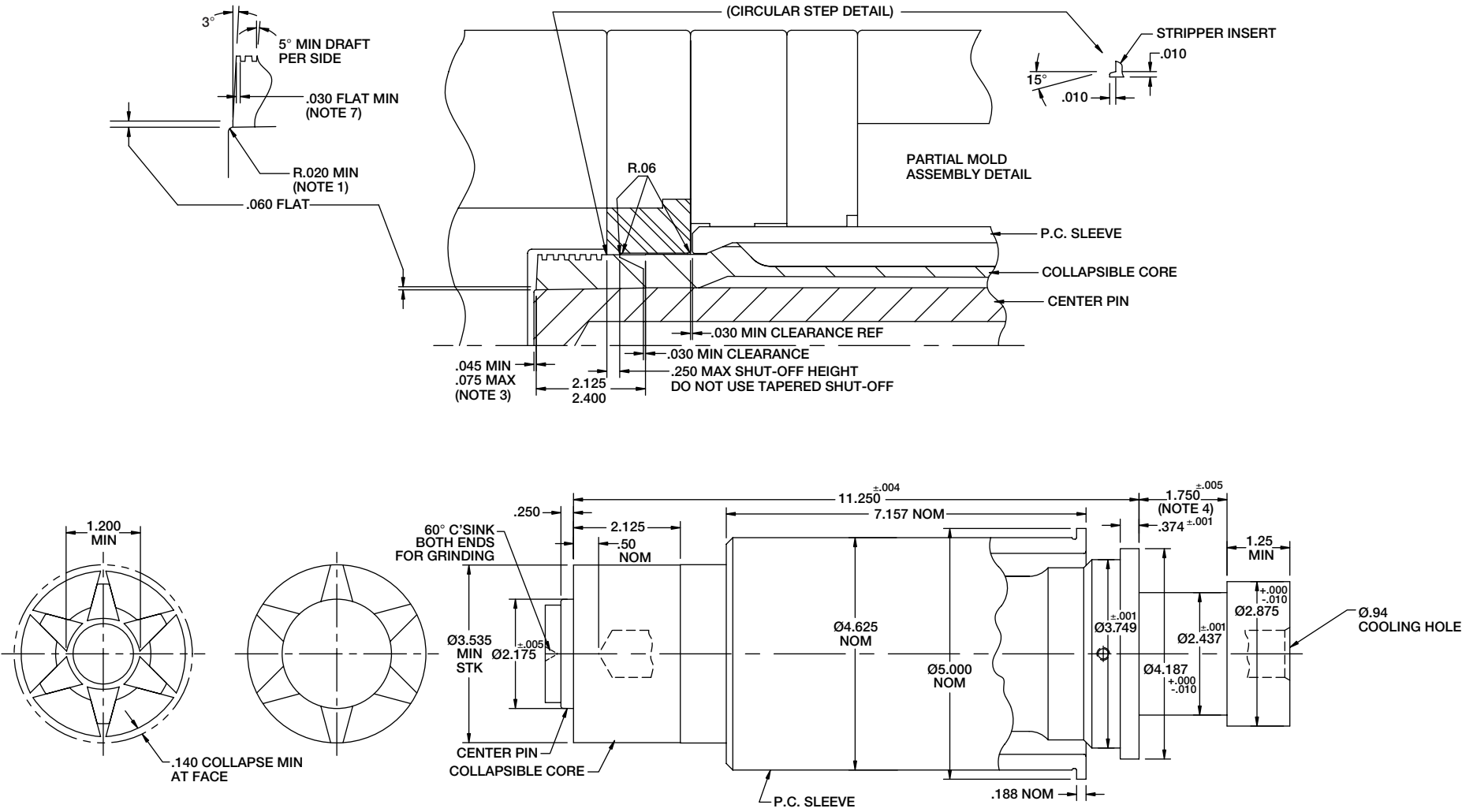

# D-M-E COLLAPSIBLE CORE

## CC 602 P.C. Core Dimensions (cont.)

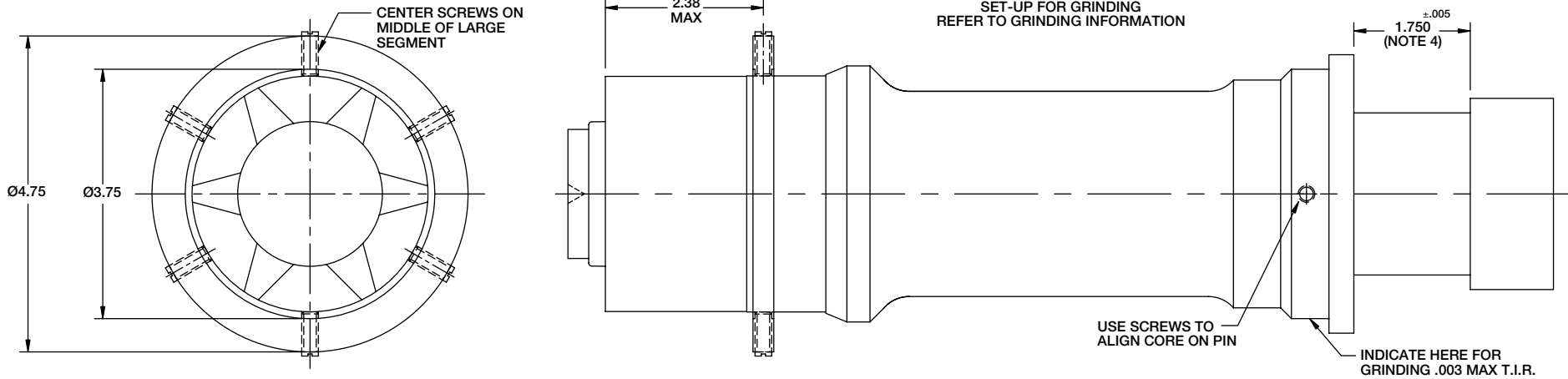

### NOTES:

1. Center pin to project .045 minimum/.075 maximum above front face of Collapsible Core with .020 R minimum at corners. See suggested partial mold assembly view.
2. Both ends of center pin to be cut off after grinding contour on Collapsible Core before assembly in mold.
3. Minimum suggested I.D. of thread or undercut is 2.610-S to give minimum steel support between depth of undercut and center pin.
4. The  $1.750 \pm .005$  dimension must be held in mold assembly and core grinding.
5. Consult Grinding Instructions.
6. 1/16 radius essential on inside corners of stripper insert, especially where shut-off contacts Collapsible Core.
7. Thread must never be run out of face of core, leaving a knife-edge of material. For complete instructions, refer to Design Procedures.
8. Do not use center pin as a pilot into "A" half of mold.

Questions? Call D-M-E at 1-800-626-6653 (U.S.) • 1-800-387-6600 (Canada) • 32-15-215011 (Europe)



# D-M-E COLLAPSIBLE CORE

## CC 602 P.C. Mold Base Machining Dimensions (cont.)

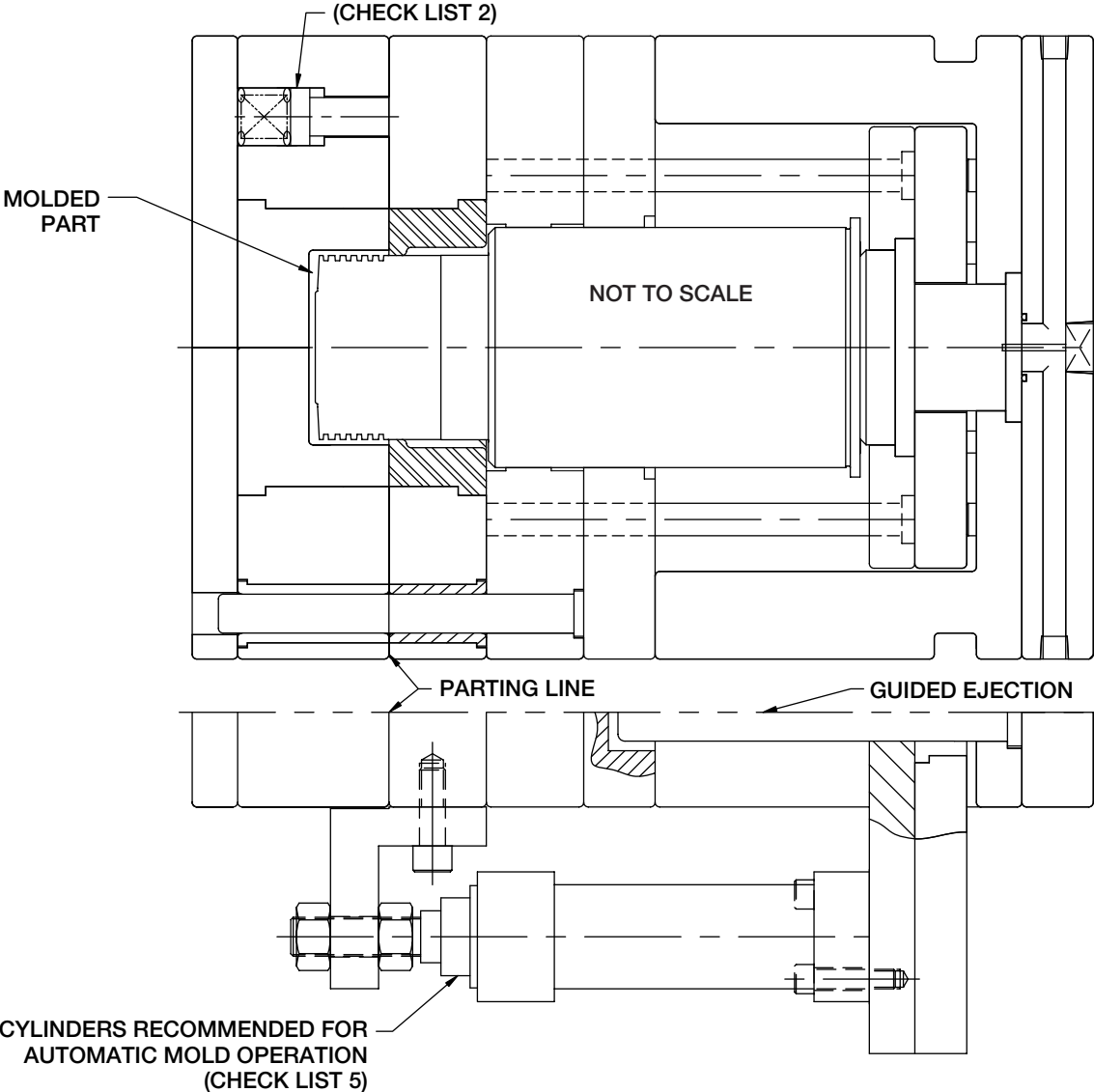

Questions? Call D-M-E at 1-800-626-6653 (U.S.) • 1-800-387-6600 (Canada) • 32-15-215011 (Europe)

### CC 602 P.C. Mold Base Machining Dimensions (cont.)

#### Mold Design Check List

1. Use guided ejector plates and a support ring around center pin. Ejector plate, support rings and rest buttons must be ground to  $1.187 \pm .001$ .
  2. Use springs to assure first break at main parting line.
  3. Return pins to end under stripper plate.
  4. Ejector plate travel to specifications. Stamp dimension on edge of plate.
  5. Secondary stripper plate actuation to begin only after full ejector plate travel. Stripper plate must return fully before ejector plate begins to return (see Sequence Description).
  6. Good venting is essential, preferable to outside of mold.
  7. Clearance between core shut-off O.D. and stripper insert I.D. to be .0013/.0018 total. Measure core when installed in mold. No tapered shut-off permitted. Avoid excessive shut-off length; .250 maximum is adequate.
  8. Mounted core to be free to turn when in ejector plate assembly.
  9. Center pin to be concentric with stripper bushing. Verify protrusion of pin through core and radius on tip of pin.
  10. Positive collapse sleeve to travel freely through plates. Apply grease where indicated. Check for free movement when mold is at operating temperature.
  11. When face of Collapsible Core segments shut-off against cavity (some parts with through holes), all cores must be ground to the same O.A.L. Normal tolerance of  $\pm .003$  is inadequate. Refer to Core Grinding Instructions. Clearance between end of core face and cavity to be .0005 to .0010. Do not pre-load the core. Whenever the above condition exists, an early ejector plate return system must be used, or the cores will be destroyed.
- NOTE:** This applies only when the core seals off against the cavity. When the pin is seating against the cavity exercise care to avoid excessive pre-load of the pin. A .000 to .0015 interference is adequate.
12. Break all sharp corners.
  13. The stripper shut-off diameter must be of the same diameter or preferably a larger diameter than any other diameter on the core.



# D-M-E COLLAPSIBLE CORE

## Collapsible Core Mold Base **ORDERING GUIDE**

For CC-200-PC, CC-202-PC, CC-302-PC, CC-402-PC, CC-502-PC, CC-602-PC

### When Ordering

1. Specify 6-plate series special stripper plate mold base.
2. Specify "AX" plate thickness as required.
3. Specify "X" plate thickness as required. Refer to technical data and drawings section for instructions to determine "X" (stripper plate) thickness.
4. Under "Special notes" request:
  - A. Ejector retainer plate  $.625 \pm .003$  (except 602, request  $.875 \pm .003$ ).
  - B. Ejector plate 1".
  - C. Cumulative height of ejector plate and reset buttons to be  $1.187 \pm .001$ .
5. Specify location, type, size and number of ejector plate guide pins.

COLLAPSIBLE CORE NUMBER	200, 202, 302	402	502	602
Top Clamping Plate Thickness	As Required by Part Design ... See Text			
AX – Thickness of Front Cavity Plate				
X – Thickness of Stripper Plate				
BX – Thickness of Rear Cavity Plate	1-3/8	7/8	7/8	1-7/8
Support Plate	1-3/8	1-3/8	1-7/8	1-3/8
C – Height of Spacer Blocks	4	4-1/2	5-1/8*	6-3/16**

\*When C=5-1/8", request three (3) piece assembly.

\*\*When C=6-3/16 request three (3) piece assembly.

**NOTE:** Mold bases for the CC-250-PC, CC-252-PC, and CC-352-PC require a 5-plate series special stripper plate mold base. Please refer to the corresponding "Mold Base Machining Dimensions" sheet for proper plate thicknesses.

**Questions? Call D-M-E at 1-800-626-6653 (U.S.) • 1-800-387-6600 (Canada) • 32-15-215011 (Europe)**

# D-M-E COLLAPSIBLE CORE

## Collapsible Core Ordering Guide Drawings

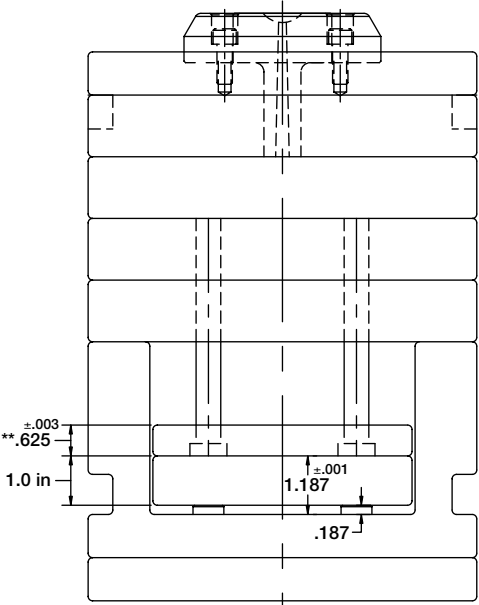
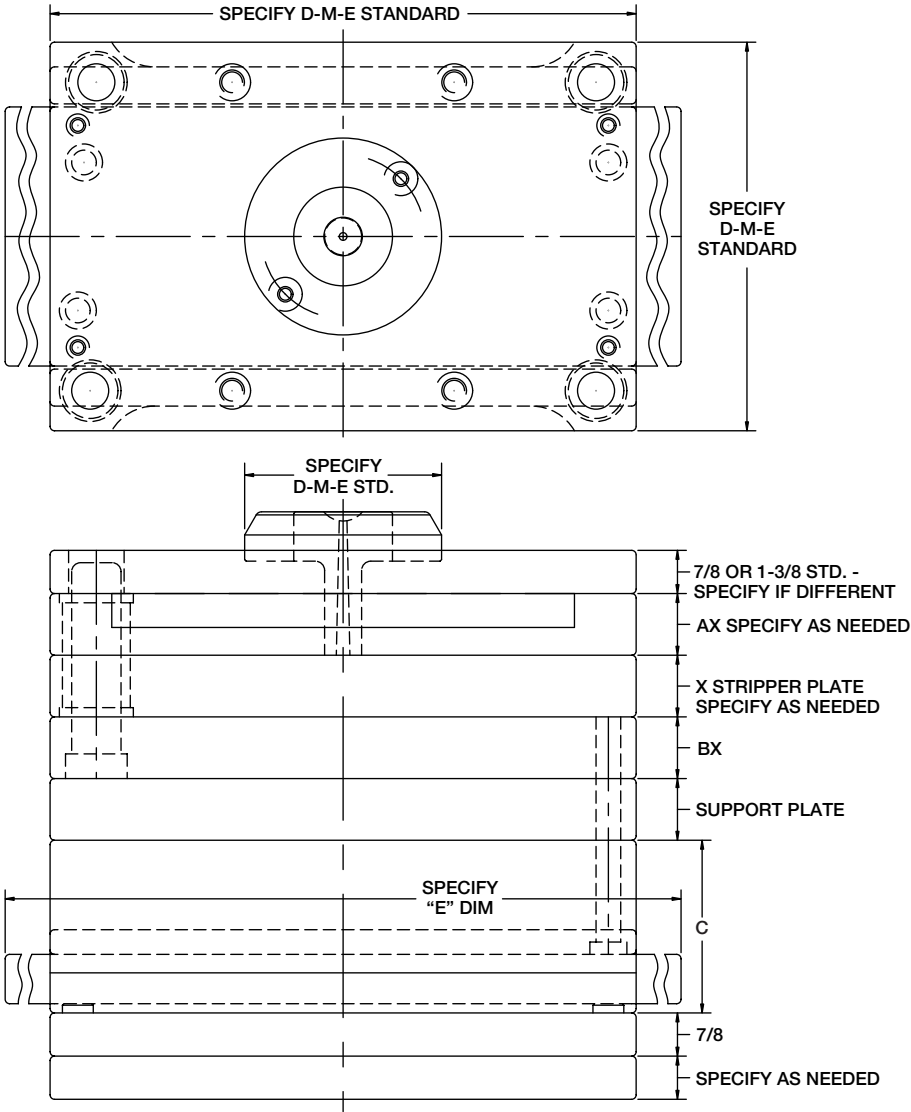

\*\* .875 $\pm$ .003 FOR CC-602-PC

# D-M-E COLLAPSIBLE CORE

## Early Ejector Plate Return – Plate Machining Dimensions

USE FOR CC-200-PC, CC-202-PC,  
AND CC-302-PC

USE FOR CC-402-PC

USE FOR CC-502-PC (NOTE 4)

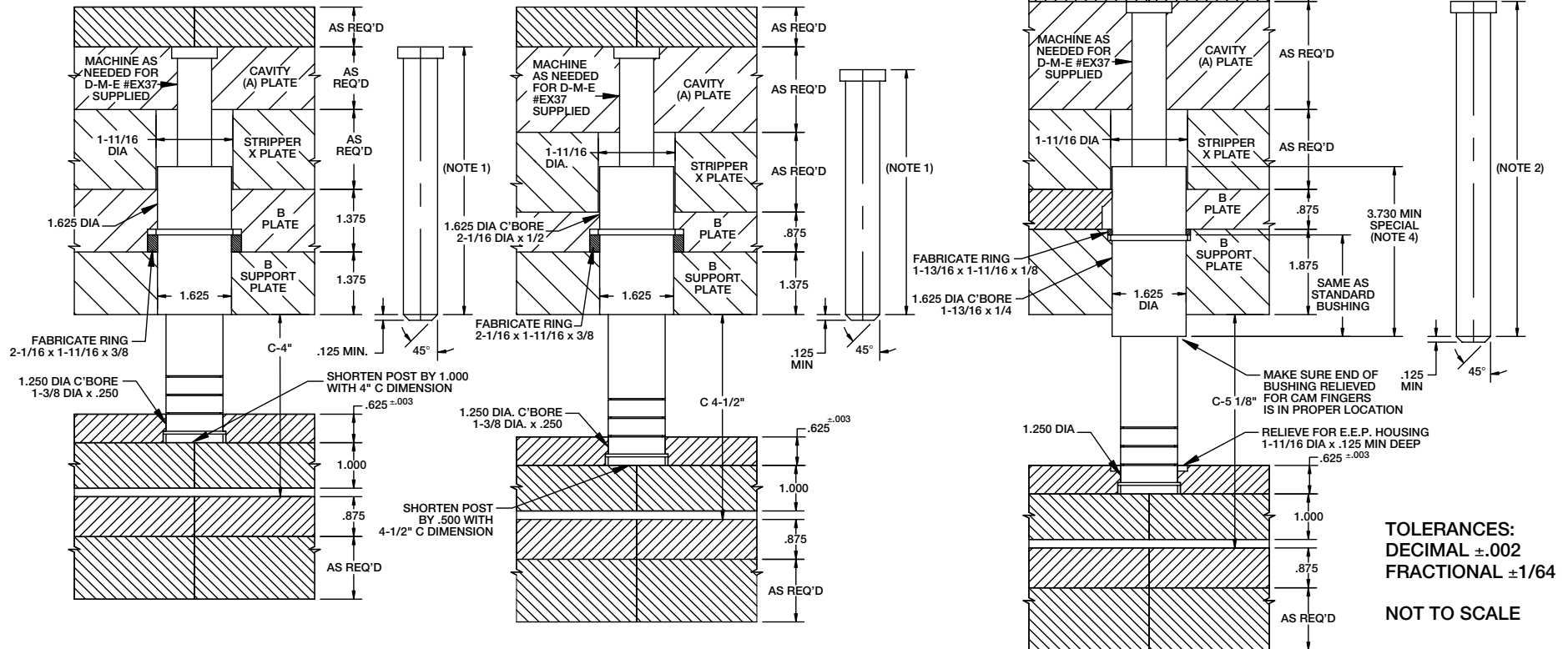

### NOTES:

- Length of pin to indicated shoulder to be total thicknesses of cavity (A) plate, stripper (X) plate, “B” and “B” support plates minimum.
- Length of pin to indicated shoulder to be total thicknesses of cavity (A) plate, stripper (X) plate, “B” and “B” support plates, plus .125 minimum.
- The D-M-E early ejector return cannot be used with the CC-602-PC collapsible core. When an early return is required for this size core, some other type must be used.
- A longer special bushing (customer must make) is required to adapt the D-M-E early return for use with the CC-502-PC collapsible core.

Questions? Call D-M-E at 1-800-626-6653 (U.S.) • 1-800-387-6600 (Canada) • 32-15-215011 (Europe)

# D-M-E COLLAPSIBLE CORE

## Early Ejector Plate Return – Operating Sequence

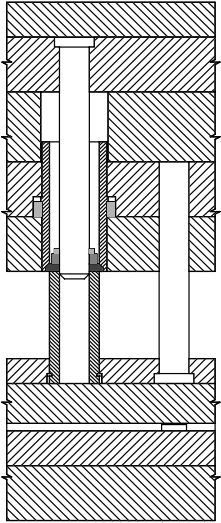

MOLD CLOSED IN MOLDING POSITION.

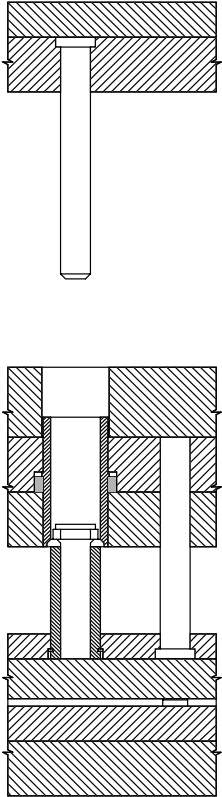

MOLD OPENING – EJECTOR PLATE HAS NOT YET CONTACTED K.O. ROD.

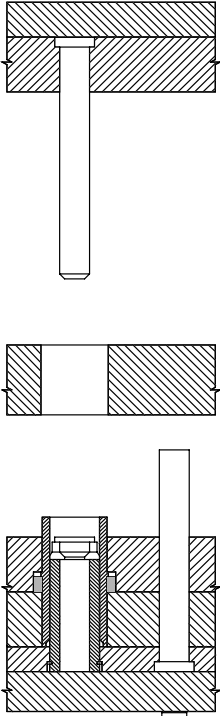

MOLD FULL OPEN – K.O. ROD HAS PUSHED EJECTOR PLATE FORWARD – STRIPPER PLATE HAS BEEN ADVANCED TO REMOVE PART BY MEANS OF CYLINDERS MOUNTED ON EJECTOR BAR.

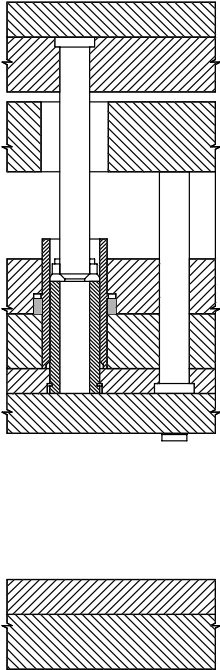

MOLD CLOSING – EARLY EJECTOR RETURN CAM FINGERS HAVE JUST CONTACTED ACTUATOR. PIN-STRIPPER PLATE HAS ALREADY BEEN BROUGHT BACK TO REST ON RETURN PINS BY THE CYLINDERS MOUNTED ON EJECTOR BAR.

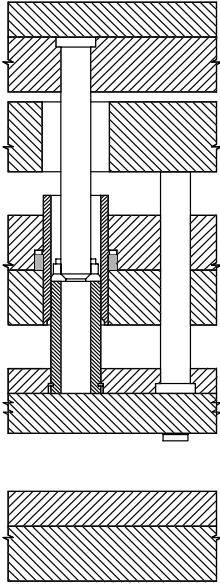

MOLD CONTINUES CLOSING – ACTUATOR PIN PUSHES ON CONICAL SURFACE OF CAM FINGERS WHICH CANNOT BACK UP BECAUSE THEY ARE CONTAINED INSIDE BUSHING AND FORCE EJECTOR PLATE BACK.

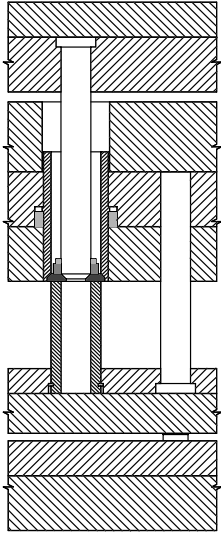

MOLD CONTINUES CLOSING – EJECTOR PLATE HAS BEEN PUSHED ALL THE WAY BACK. RETURN CAM FINGERS HAVE SLIPPED OUTWARD INTO COUNTERBORE IN BUSHING ALLOWING ACTUATOR PIN TO SLIP BY. MOLD CONTINUES CLOSING UNTIL COMPLETELY CLOSED.

NOT TO SCALE

**NOTE:** For small molds use 4 early ejector return assembly units. For large molds 6 or more assembly units may be required.

## D-M-E COLLAPSIBLE MINI-CORE

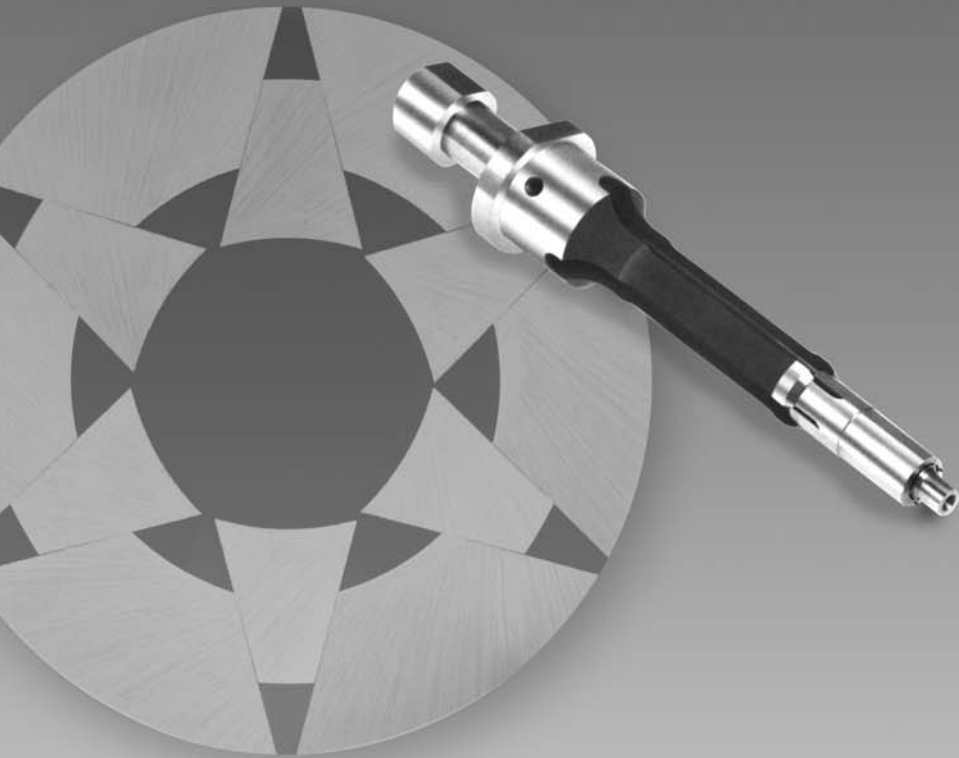

### D-M-E Collapsible Mini-Core: Description of Components and Basic Operation

#### Mini-Core (With Three Wide Collapsing Segments)

The Collapsible Mini-Core is manufactured from AISI type A-2 steel hardened to 51 to 57 Rockwell "C". It has three wide segments designed to collapse independently when the center pin is withdrawn. The fit between segments is controlled to permit flash-free molding for most thermoplastic materials. The location of the mini-core on its pin is critical. The distance between the back of the core head and the front of the center pin head (head space) is critical and must be maintained for both grinding and in the mold. A grinding head space dimension of  $1.562 +.005/-.000$  must be held for core grinding. The head space dimension held in the mold base assembly is  $1.562 +.000/-.005$ . These tolerances are intentionally different to assure that the top of the center pin blades never fall below the top of the core segments when installed in the mold. If this occurred, plastic material would be molded behind the core segments, preventing them from collapsing, resulting in serious damage to the core. The unit is designed to operate without benefit of lubrication. However, if lubrication is permissible, a lightweight lubricant such as polytetrafluoroethylene should be used since it will extend the life of the components as with any moving steel to steel contact. Plating the mini-core segments or its center pin is not recommended. However, certain alloying processes have been successfully used for wear reduction or corrosion resistance. Please consult D-M-E Company Applications Engineering Department for specific details.

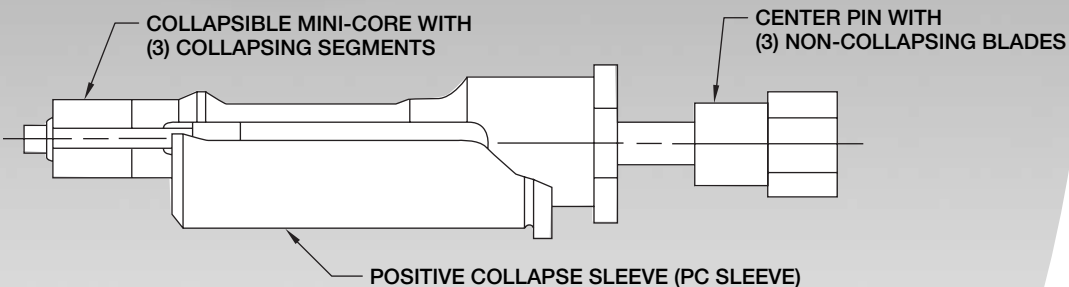

The D-M-E Collapsible Mini-Core is a three-unit assembly designed for simplicity of installation, reliability in operation and long life. The three units are a Collapsible Mini-Core, center pin, and a positive collapse sleeve.

Questions? Call D-M-E at 1-800-626-6653 (U.S.) • 1-800-387-6600 (Canada) • 32-15-215011 (Europe)

## D-M-E COLLAPSIBLE MINI-CORE

### D-M-E Collapsible Mini-Core: Description of Components and Basic Operation (cont.)

The individual segments have a “self-cleaning” action and will tend to carry any dirt or deposits to the outer surface of the collapsing core. The first 50 to 100 shots in operation may show foreign matter deposits on the inside of the molded part. Prior to final assembly of the mold, the collapsing core should be thoroughly degreased and cleaned. A light wipe of grease can be given to the top of the center pin radius for break-in purposes. A lightweight lubrication of P.T.F.E. should be used if possible, based on the requirements of the parts being molded. A heavyweight grease type lubrication must not be used on the core or center pin.

The mini-core must be located with a key to closely align it with the center pin. Before the key is installed, it is recommended that the core be free to turn in the ejector retainer plate. Even with the key installed, about .005 clearance with the alignment flat should permit the core to “float” slightly, therefore allowing the core to locate itself on the center pin blades.

To completely collapse the mini-core, the core must be lifted off the center pin a specified amount. This distance between the back of the “BX” support plate and the front of the ejector retainer plate is  $1.688 \pm .005$  for all three mini-core sizes: CCM-0001, CCM-0002 and CCM-0003. A  $.207 +.003/-.002$  deep counterbore must be held in the bottom of the “BX” support plate for the head of the PC sleeve. This actuates the PC sleeve, causing the segments to collapse if they have not collapsed from their built-in memory. If necessary to deviate from this dimension, consult D-M-E Applications Engineering Department.

Stripper plate actuation by cylinders must only begin after full ejector plate travel. Cylinders must return stripper plate fully before ejector plate begins return. It is recommended that the ejector assembly be held in its full forward position until the stripper plate is fully returned. This will avoid interference of the stripper insert with the core and possible mini-core damage (see Core Sequence Description).

Collapsible Mini-Cores are individually fitted to a matching numbered center pin and cannot be interchanged. Also, only assemble core and pin with the alignment flats parallel and on the same side.

**NOTE:** Never permit a ground thread to run out through the top of the core. This leaves a knife edge of steel that will break off in time. Instruct the grinder to lift the thread grinding wheel out of the core before the thread breaks through the top of the core. See drawing in core grinding instructions.

### **D-M-E Collapsible Mini-Core: Description of Components and Basic Operation (cont.)**

#### **Center Pin (With Three Non-Collapsing Narrow Blades)**

The center pin serves to expand the segments of the mini-core to their molding position and holds them at this diameter. Blades at the molding end of the center pin fit closely between the collapsing segments of the mini-core. When the core is lifted off the center pin blades, room is provided for the mini-core segments to collapse. A hole is provided in the center pin for cooling. The center pin is manufactured of a high alloy type D-6 tool steel hardened to 60 to 65 Rockwell "C", except for the head area, which is a soft stainless steel, and is brazed to the center pin shaft. Refer to the pin grinding instructions for machining directions. In use, the pin must incorporate two design features. The pin must protrude beyond the top of the collapsing core segments by certain amounts; refer to Dimension F in the Table of Dimensions. A radius must be applied to the .300, .420, or .560 diameters of the center pin above the top of the core. This protrusion must keep material from flowing behind the segments that would prevent their collapse. The sharp edge resulting from cutting the pin to length will gall and subsequently destroy the inside surfaces of the collapsing mini-core segments; refer to Dimension R in the Table. Center pin must be keyed to align properly with the mini-core.

The standard mold base machining dimensions provided in the Collapsible Mini-Core drawings assume a maximum pin protrusion of .031. When greater protrusion is needed, a special center pin and certain dimensions in the mold base must be altered, consult D-M-E Applications Engineering Department. Center pins are fitted to a specific core and cannot be interchanged. Always assemble core and pin with alignment flats parallel and on the same side. Always verify serial numbers and flat alignment of core and pin prior to assembly or grinding. Replacement center pins to fit Collapsible Mini-Cores are available on special order.

### **D-M-E Collapsible Mini-Core: Description of Components and Basic Operation (cont.)**

#### **Positive Collapse Sleeve**

The positive collapse sleeve (PC sleeve) is designed to function when any of the Collapsible Mini-Core segments fail to collapse independently upon withdrawal of the center pin. In normal operation, the PC sleeve is not functioning. It is essential to have such a unit for maximum safety and reliability in automatic and semi-automatic operation. Under no circumstances should a mold be placed into operation without the use of the PC Sleeve.

The PC sleeve is uncomplicated in operation. An angular surface on the inside of the front edge of the PC sleeve will engage a matching angular surface on the outside of the Collapsible Mini-Core when the un-collapsed mini-core is moved forward in the PC sleeve. This interference action is achieved by restricting the travel of the PC sleeve to an amount less than the forward travel of the Collapsible Mini-Core.

It is essential that no variation be permitted from the dimension given between the rear of the back support and the front of the ejector retainer plate. The  $.207 +.003/-.002$  deep counterbore for the head of the PC sleeve must also be maintained. Do not deviate from these dimensions without prior approval of D-M-E Applications Engineering Department. Any variation from these dimensions will adversely effect the operation of the PC sleeve and may cause destruction of the mini-core.

PC sleeves are interchangeable between different serial numbers of the same catalog number (size) core.

#### **Tapered Work Arbor for Grinding (With No Blades or Head)**

The tapered work arbor is used for grinding threads or undercuts on collapsing mini-core segments only.

#### **Clamping Ring for Grinding (With Set Screws)**

The clamping ring for grinding is used to hold mini-core segments in place during all grinding operations of the mini-core.



## D-M-E COLLAPSIBLE MINI-CORE

### Desired Sequence of Operation of Collapsible Core for Automatic Mold Operation

As indicated on each Mold Base Machining Dimension drawing for the Collapsible Mini-Core, the cross section depicts a typical collapsible core mold design. The collapsible core is mounted in the ejector retainer plate; the center pin is mounted in a bottom clamp plate. An extended stripper plate has been incorporated for proper ejection and cylinders are shown installed for the last stage of the required two-stage ejection. Also, vital to the design is the usage of guided ejection.

The molding sequence can easily be followed by starting with the opening of the press: the press opens and the mold parts at the main parting line. When sufficient mold open is achieved, the ejector plate assembly is moved forward by mechanical or hydraulic knockouts of the press. The ejector plate assembly with the collapsing core is moving forward the necessary stroke required to move the core off of the center pin and collapse the core (this is the first stage of ejection).

If the segments of the core fail to collapse for any reason during this stage, the positive collapse sleeve will come into play and ensure the start of the collapse. In addition, the stripper plate and ejector plate assembly move together because of the return pins located directly under the stripper plate. This simultaneous movement continues until the ejector plate assembly is full forward. At this point, a limit switch is actuated. This in turn actuates the cylinders to take over and to continue to move the stripper plate with the stripper insert, moving the part away from the collapsed core (second stage).

When automatic part stripping is required, means must be provided for carrying the molded part off of the collapsed core at the completion of the ejector stroke. This is commonly done by providing a ring projection (.010 x .010 min.) on the face of the stripper insert. Shock dislodges the part from this ring and permits it to drop out of the mold at the end of the stripper stroke. The part must not drag over the core. When removing the part manually, the stripper ring and the cylinders are not required.

Please note that the stripper plate actuation must be sequenced so that the cylinders have returned the stripper plate before the ejector plates are returned. This applies to all parts whether through molded or not. The stripper plate must always be returned to its original position before re-expanding the core. This will avoid interference of the stripper insert with the core and possible core damage.

When the top face of the collapsible core shuts off against the cavity, all cores must be ground to the same overall length. In addition, whenever this condition exists, an early ejector return must be employed. The early ejector return will ensure that the core is expanded before the mold closes at the parting line.

## Design Procedure – Plastic Parts To Be Molded on Collapsible Mini-Cores

### General Considerations

All commonly used thermoplastic molding resins, including filled materials, has been successfully molded on Collapsible Cores. Vinyl resins have been tried. Certain injectable thermosets have also been tried. In addition, cores must be treated with a corrosion resistant process, such as a dense nodular chrome (contact D-M-E). (However, in general, we cannot recommend thermosets due to extreme ease of flashing and the very abrasive nature of many of these materials.) For high temperature applications over 650°F, contact D-M-E.

Good plastic design practice should be observed to avoid such conditions as distortion, sink marks, etc. These problems and their solutions are identical to those found in conventional molding. Adequate venting is important. Gasses must always be vented to the outside of the part away from the mini-core and center pin.

The illustrations in the Table show only the very simplest type of part, which can be molded on the Collapsible Mini-Core. Three interruptions in the thread or undercut are required by the three non-collapsing blades on the mini-core center pin. Therefore, undercuts cannot be continuous. See the chart for the width of the non-collapsing blades at the top of the mini-core. These non-collapsing blades, when the core is lifted off the center pin, provide room for the three mini-core wide segments to collapse. Molded parts need not be closed at one end. They may be partially open or even completely sleeve shaped. Early ejector returns and special close tolerances are required when shutting off on the top of the core segments. Openings may be formed in the sidewall of molded parts by extending projections on the surface of the Collapsible Mini-Core to shut off against the cavity wall. However, please contact D-M-E Applications Engineering Department concerning these types of shut-offs and for specific requirements concerning unusual applications and for special requirements and questions concerning the mini-core.

### Part Design – Molding Feasibility

The following steps are used to determine if a part can be molded on the Collapsible Mini-Core (refer to enclosed figures and tables):

#### Undercut

- ◆ Determine that undercuts C required by the part design do not exceed the collapse available in the Collapsible Mini-Core. Identify all actual undercuts on the part drawing, and define the effective locations of L for each one as follows (see Table 2-1 and Fig. 2-1A and 2-1B):
- ◆ An undercut is defined as “one-half of the difference between ANY larger diameter and ALL smaller diameters located at a greater distance from the end of the Collapsible Mini-Core. [.5 x (A-B).]
- ◆ Determine that the part major diameter A (the largest interior diameter) is not greater than the A maximum value (Fig. 2-1A and 2-1B) given in Table 2-1.
- ◆ Determine that the part minor diameter B (the smallest interior diameter) is not less than the B minimum value (Fig. 2-1A and 2-1B) given in Table 2-1.

### Design Procedure – Plastic Parts To Be Molded on Collapsible Mini-Cores (cont.)

- ◆ The location L of such an undercut is defined as “the distance from the face of the Collapsible Mini-Core to the largest diameter producing the undercut.”
- ◆ The amount of collapse listed is the amount that is achieved by the segments to obtain the fully collapsed dimension.

#### Loss of Collapse

When collapsed, the core segments bend inward at about 1°. The collapse available decreases from the front of the core at the rate of .020/in. per side. In determining part design feasibility, the maximum part undercut must be computed using the factor of (.020 x L). Therefore, a core collapsing .057 at the top of the segment will only have .047 collapse available .50 back. [.057 – (.020 x .50) = .047.] Based on this information, it is obvious that part design must allow for the decrease in collapse of the core as a factor of part depth.

#### Shrinkage

Calculate the expected actual shrinkage “S” of the part along its diameter.

**NOTE:** In actual use, less than 1/2 of the material shrinkage occurs in the mold. You may, based on your experience, compensate for this by using one-half of the total material shrinkage in computing S.

#### Clearance

Use .005 clearance/side on all mini-cores.

#### Total Collapse

Undercut + Loss of collapse + Shrinkage + Clearance = Total Collapse per side at top of core

**NOTE:** Make sure total collapse does not exceed maximum collapse in Table 1, Item ‘C’.

**IMPORTANT:** Determine that part depth D (Fig. 2-1A and 2-1B) does not exceed the value given in Table 2-1. For special applications, consult the D-M-E Applications Engineering Department.

Verification of basic dimensions A, B, C and D will assure that the part does not exceed design limits of standard Collapsible Mini-Cores. Departure from standards is frequently possible with specially designed mini-cores. Consult D-M-E Applications Engineering Department to determine if it is possible to make a special mini-core for your application if it should fall outside the standard core range (including longer molding lengths, special diameters, special collapse and even numbers and size of segments).

### Part Design – Detail Requirements

The design of the part must have the following details and features for successful operation:

1. It must be acceptable for the part to have a thread or undercut area that is not continuous. The standard mini-core is interrupted in three areas.
2. The pin must protrude beyond the core face (Fig. 2-2) by at least the distance F given in Table 2-1. Protrusion of up to .031 (.031 maximum is supplied as standard) is permissible. For protrusions greater than .031, contact D-M-E Company Applications Engineering Department to determine special conditions. Radius R is extremely important.
3. There must be no undercuts on the O.D. of the center pin blades or on the top of the mini-core segments. Otherwise, the molded part could not be ejected or the mini-core segments collapsed.
4. Any undercuts on the top of the center pin (Fig. 2-2) must not interfere with full radial movement of the Collapsible Mini-Core segments. They must either be located forward of the top of the core or be confined within a diameter smaller than the collapsed inside diameter G (Table 1) of the Collapsible Mini-Core. In no case should the undercuts be so deep that they come close to the cooling hole in the center pin. Special pins can be supplied for these cases (see Collapsible Mini-Core dimension drawing).
5. The top of the core (Fig. 2-2) must have a draft of at least 3° starting no further than .030 from the surface of the pin.
6. All undercuts must have a draft in relation to the direction of the collapse of each mini-core segment. A minimum draft of 5° is required (Fig. 2-2). Interrupted undercuts (Fig. 2-3) also require a side draft of at least 5°.
7. Means must be provided for carrying the molded part off the collapsed mini-core at the completion of the ejector stroke. This is commonly done by providing a ring projection (step detail) (.010 x .010 minimum) on the face of the stripper bushing (Fig. 2-2). Shock must dislodge the part from this ring and permit it to drop out of the mold at the end of the stripper plate stroke. The part must not drag over the core.

**NOTE:** This feature may be omitted when automatic part ejection is not required and each part will be manually removed from the mold.

8. As in conventional practice, sharp interior corners on the core or pin must be avoided to prevent stress concentration in the steel. A smooth radius should always be used if possible. However, outside edges of the center pin blades must be left sharp to keep plastic material from being molded where it would interfere with collapse of the segments.

See following pages for figures and table.

## D-M-E COLLAPSIBLE MINI-CORE

### Table of Dimensions

Table 2-1

COLLAPSIBLE MINI-CORE	CCM-0001	CCM-0002	CCM-0003
A Maximum part I.D. for configuration or major thread diameter.	.645-S	.805-S	.965-S
B Minimum part I.D. for configuration or minor thread diameter	.425-S	.560-S	.710-S
C Maximum part undercut at L (See Text)	.052	.057	.059
D Maximum part depth (See Text)	.850-K	.850-K	1.000-K
E Length of fitted surface on mini-core	.850	.850	1.000
F Pin protrusion minimum (See Text)	.015	.015	.015
G Collapsed inside diameter of mini-core, Fig. 2-3	.09	.18	.31
H Pin diameter at top of core	.300	.420	.560
J Width of each (3) non-collapsing center pin blades (at top of core)	.170	.190	.200
K Stripper bushing seal-off length recommended minimum, Fig. 2-2	.150	.150	.150
R Pin tip radius, Fig. 2-2 (round diameter only, no radius on blades)	.010*	.010*	.010*
S Plastics material shrinkage (See Text)	Plastics material shrinkage factor X part dimension	Plastics material shrinkage factor X part dimension	Plastics material shrinkage factor X part dimension

\* A pin tip radius of .010 is required for .015 pin protrusion. If the pin protrusion is .030, then .020 pin tip radius should be used. No radius can be on the center pin blades or material would be formed behind the segments, preventing them from collapsing. The top of the center pin blades must never be below the face of the core for the same reason.

**Questions? Call D-M-E at 1-800-626-6653 (U.S.) • 1-800-387-6600 (Canada) • 32-15-215011 (Europe)**

# D-M-E COLLAPSIBLE MINI-CORE

## Drawing Figures for Table of Essential Dimensions

Fig. 2-1A

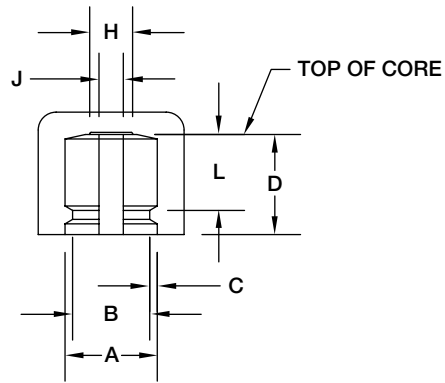

(ROTATED 180° FROM FIGURE 2-2)

Fig. 2-1B

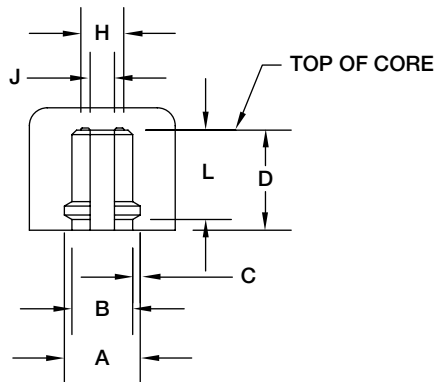

(ROTATED 180° FROM FIGURE 2-2)

Fig. 2-2

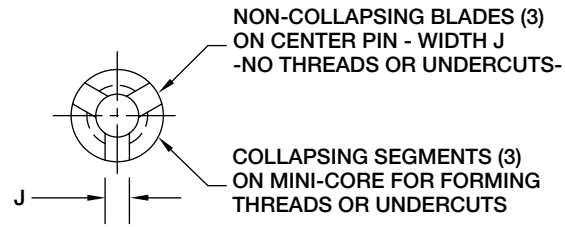

NON-COLLAPSING BLADES (3)  
ON CENTER PIN - WIDTH J  
-NO THREADS OR UNDERCUTS-

COLLAPSING SEGMENTS (3)  
ON MINI-CORE FOR FORMING  
THREADS OR UNDERCUTS

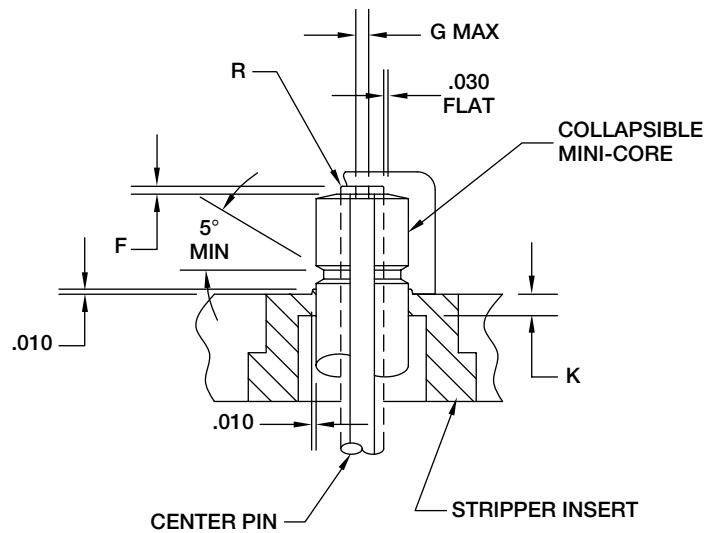
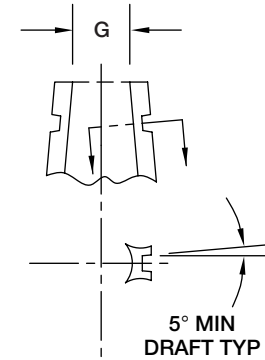

Fig. 2-3



**NOTE:** Dimensions H and J apply only at the top of the core since both the center pin diameter H and blade width J are tapered.

### Design Check List and Mold Start-Up Procedures

Things to look for in mold design and in checking out mold prior to operation:

1. Use support ring around center pin. Ejector plate, support rings and rest buttons must be ground to  $1.187 \pm .001$ .
  2. Always use guided ejection for the ejector assembly. D-M-E guided ejection bushings locate ejector retainer plate and core with the rest of the mold.
  3. Use springs to assure first break at main parting line. (Mold must open at main parting line prior to ejector assembly pushing stripper plate forward.)
  4. Return pins to end under stripper plate. (Return pins must never run through the stripper plate.)
  5. Ejector assembly must travel to full forward specification. Moldmaker to stamp " $1.688 \pm .005$  ejection stroke required" on visible edge of mold plate.
  6. Stripper plate actuation by cylinders to begin only after full ejector plate travel. Cylinders must return stripper plate fully before ejector plate begins return. It is recommended that the ejector assembly be held in its full forward position until the stripper plate is fully returned (see sequence description).
  7. Good venting is essential, preferably to outside the mold. Do not vent part into core or center pin.
  8. Clearance between core shut-off O.D. and stripper insert I.D. to be a total of  $.0010/.0015$  at room temperature. Measure core when installed in mold. No tapered shut-off is permitted. Avoid excessive shut-off length,  $.150/.250$  is adequate.
  9. Core must be located with a key in the ejector retainer plate (key to have about  $.005$  clearance with alignment flat on core). This prevents the core from rotating and aligns it closely with the center pin to orient center pin blades between the core segments.
  10. Center pin must be located with a key in the bottom of the housing (key to have about  $.005$  clearance with alignment flat on pin). This prevents the pin from rotating and aligns it closely with the core to orient center pin blades between the core segments.
- NOTE:** Alignment of both keys for core and pin is essential for proper fit, they must be parallel and on the same side.
11. *Important:* When core and pin are assembled in mold with  $1.562 +.000/-.005$  head space dimension, check to make sure that narrow blades on the center pin are never below the top of the collapsing segments.

**NOTE:** A recess of the narrow blades below the top of the core segments will result in core damage.

### Design Check List and Mold Start-Up Procedures (cont.)

12. Center pin to be concentric with stripper bushing. Verify .015 pin protrusion beyond top of core and a minimum of .010 radius on tip of pin. Pin tip radius must always be slightly less than the pin protrusion to prevent plastic material from being formed behind the core segments. No radius permissible on center pin blades. Examine pins for evidence of any de-temper of pin tip due to overheating in grinding. Water line bubbler tube in center pin must not throw pin off or cause pin to be improperly mounted.
13. Positive collapse sleeve to travel freely through 'BX' support plate. Apply grease lightly to O.D. of positive collapse sleeve. Check for free movement when the mold is at operating temperature.
14. When top of core segments shut-off against cavity (example, some parts with through holes), all cores must be ground to the same length (O.A.L.). The normal tolerance of  $\pm 0.003$  is inadequate and may overload core. Refer to "Alterations to Collapsible Mini-Core" section for core grinding instructions. Clearance between top of core and cavity to be .0005 to .0010. Do not pre-load core. Whenever the above condition exists, an early ejector return system is mandatory.

**NOTE:** This applies only when top of collapsing core segments shut off against the cavity. Also, exercise care to avoid pre-load on center pin. A .0000 to .0015 interference is adequate. Also, whenever above condition exists, the head space dimension in the mold must be held to exactly what was used to grind the length (O.A.L.) for each core with a tolerance of +.000 to -.001. All cores must be set up for grinding with exactly the same head space using a tolerance of +.0010 to -.0000. This must be done to prevent the top of the blades on the center pin from ever falling below the top of the collapsing segments on the core, which would cause serious damage to the core if it occurred.

15. Check finish on cores:
  - a. Surface finish and polish must be smooth and allow the segments to collapse freely when plastic material is molded on the core.
  - b. Undercuts must be in direction of collapse, no back hooks due to improper grinding or design.
  - c. Proper design procedures must be adhered to.
16. Observe proper care in dry cycling:
  - a. Plate cocking or bounce should not occur and must be immediately corrected if observed.
  - b. Audible sounds or visible indications of friction, mis-aligning or scoring must be corrected immediately.
  - c. Sequence of movements must occur correctly (see Sequence Description).
  - d. Positive collapse sleeve must move freely and be properly actuated when the ejector assembly is fully forward.
17. Threads ground into Collapsible Mini-Core should not run out to a feather/knife edge.



# D-M-E COLLAPSIBLE MINI-CORE

## Mini-Core O.D., as well as Collapsing Segment Thread and Undercut Grinding Recommendations

### General

1. Mini-core and pin must be cleaned thoroughly prior to assembly for grinding.
2. To assemble Collapsible Mini-Core for grinding, first align both flats on the heads of the core and pin parallel and on the same side. Then assemble so that the top of the core and the top of the center pin blades are flush. This will ensure the grinding head space dimension of 1.562 +.005/-.000 is established. Refer to core dimension and grinding set-up drawings and information for details. Hold this position by using three set screws near head of core to lock assembly in position during grinding and to true the core on the pin between centers. Concentricity is extremely important, refer to grinding set-up drawing for details.

**NOTE:** Cores are factory positioned, but must be reset by grinder because of possible movement in transit.

3. During grinding of core, do not use air blast or water jet at high pressure for cooling, since this may force grinding grit between the segments.
4. Use a medium grade grinding wheel such as a 32A80.K8VG for core assembly. O.D. of mini-core and center pin blades are of different Rockwell hardness and materials.

### Procedure

1. Be sure clamping ring is positioned forward (toward the top of core) and that the set screws are centered on the three wide collapsing segments. If necessary, the clamping ring may be located away from the core face but not to exceed the following dimensions.

**NOTE:** Do not over tighten set screws.

CORE TYPE	MAX. DISTANCE OF CLAMPING RING SCREWS FROM TOP OF CORE
CCM-0001	1.050
CCM-0002	1.050
CCM-0003	1.200

With core and pin assembly prepared as outlined above, rough grind desired molding and shut-off diameters approximately .008 oversize.

**Questions? Call D-M-E at 1-800-626-6653 (U.S.) • 1-800-387-6600 (Canada) • 32-15-215011 (Europe)**

## D-M-E COLLAPSIBLE MINI-CORE

### Mini-Core O.D., as well as Collapsing Segment Thread and Undercut Grinding Recommendations (cont.)

2. Removing clamping ring, loosen set screws and disassemble core and pin. Clean components to ensure grinding grit is removed from between segments and pin. Reassemble by repeating set-up instructions in A – General, Steps 1 and 2.
3. To grind final molding and shut-off diameters, it is recommended that the clamping ring be applied over the shut-off and vice versa (shifted) for the opposite diameter. Do not exceed the recommended maximum distance of the clamping ring from the top of the core (see grinding set-up drawings and information).
4. Always use the clamping ring for buffing or polishing of surface areas.
5. It is recommended that you demagnetize core and pin after grinding but before cleaning to allow grit to flush away from between the segments.

### Thread Grinding Instructions

After bringing the molding diameter to dimension, remove the center pin and use the tapered work arbor supplied. This arbor has the same taper as the core I.D. By adjusting the tapered work arbor in or out of the core, bring the core to the final diameter, which was ground with the center pin in the previous operation. Between centers, indicate and true up core using three set screws located near the head end of the core. This prevents slippage of the core on arbor during thread grinding.

**IMPORTANT:** See grinding set-up drawings and information for maximum run out. Place grinding ring (supplied) on the shut-off diameters (as close to top of core as possible).

**IMPORTANT:** See tables in grinding instructions for maximum distance allowed. Center set screws on middle of each of the three collapsing segments. Tighten evenly but do not over tighten.

Never permit a thread to run out through the face of the core. This leaves a knife edge of steel that will break off. Instruct grinder to lift the thread grinding wheel out of core before thread breaks through the top of the core, see Fig. 2-4. Do not cut any threads or undercuts on the O.D. of the three center pin blades. These center pin blades do not collapse and molded part would be locked on the center pin. Undercuts must never be cut in any area of the segments or center pin that would allow plastic material to interfere with collapse of the segments.

Replacement center pins can be custom fitted to a mini-core upon special request.

Fig. 2-4

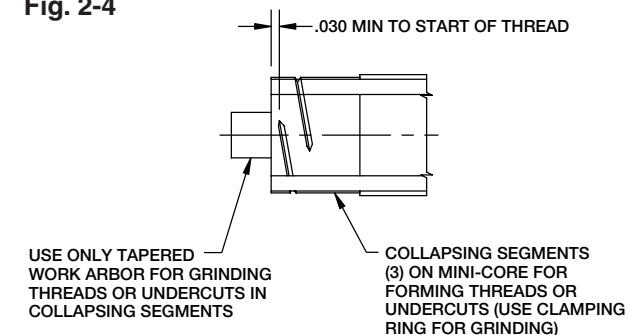

# D-M-E COLLAPSIBLE MINI-CORE

## Center Pin Cut-Off and Grinding Instructions

The center pin component of the assembly is made of AISI D-6 tool steel (except for the head, see note below) and is through hardened to 60-65 Rockwell “C”.

**NOTE:** The head of the center pin is of a soft material, AISI stainless steel, brazed to the shank of the hardened center pin. To avoid overheating and cracking, the subsequent procedures must be followed. At all times, grinding must be done under coolant flood, using a coolant suitable for hardened steels. Lack of sufficient coolant, heavy cuts, rapid plunging or infeeding will result in overheating and a loss of hardness or cracking.

The center pin has been ground on its own centers. The Collapsible Mini-core has been ground true to the centers of the pin supplied with the assembly. Refer to the core grinding instructions for set-up.

### Step 1

EDM cut-off is preferred, but cutting off of the center pin can be done with a resin cut-off wheel in an O.D. grinder with the center pin rotating and heavy flood coolant. Use coolant suitable for hardened tool steel.

- A. When cutting off the molding end of center pin (end with the three blades): The head is held in a chuck, and the pin body in a steady rest as close to the blades as possible. Indicate true before cut-off. Leave 0.025 to 0.035 extra stock for final facing. Flood coolant must be used.
- B. When cutting off head end: The center pin can be chucked on the long, straight body diameter beyond the head. Again, true before cutting off and leave .025 to .035 for final facing. Flood coolant must be used.

**NOTE:** Pin head is brazed onto center pin.

### Step 2

Final facing of both ends of the center pin is done with an abrasive wheel in an O.D. grinder with the pin rotating, holding the pin in the same manner as when cutting off (see A and B above).

Surface grinding the OAL is also acceptable under Flood Coolant.

**IMPORTANT:** Flood coolant suitable for hardened tool steels must be used along with a slow feed. Do not grind with a loaded wheel (dress wheel frequently). The wheel must be of a soft grade (60J, 46J, etc.) and must be used with a sharp cutting land. This is very important. See center pin cut-off Fig. 2-5 which shows the permissible cutting land.

Fig. 2-5

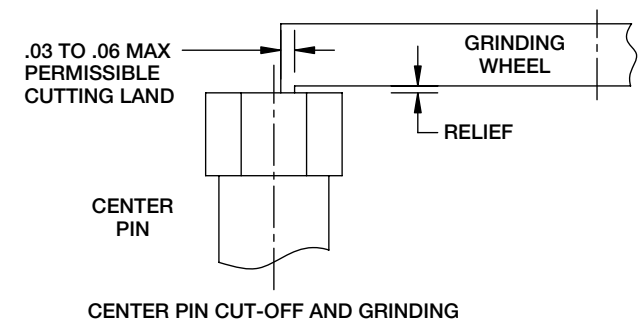

Questions? Call D-M-E at 1-800-626-6653 (U.S.) • 1-800-387-6600 (Canada) • 32-15-215011 (Europe)

### Alterations to Collapsible Mini-Cores

#### **In shortening the length (O.A.L.) of a mini-core, the following procedure must be used:**

First, the mini-core should be removed from its original center pin and the core thoroughly cleaned. The core is then placed on the tapered work arbor supplied with the mini-core for grinding. The work arbor has a taper ground on the front end that matches the mini-core I.D. and has centers both front and rear. Insert the tapered end of the work arbor into the Collapsible Mini-Core until the diameter of the mini-core, when measured over the positive collapse bumps, coincides with this diameter as measured while the mini-core is on its own center pin with the specified grinding head space dimension of  $1.562 +.005/-.000$ .

When using a work arbor (with no head or blades) or even a special work center pin (with head and blades), do not attempt to locate the mini-core for grinding by setting its standard grinding head space. This will almost never be the correct setting for the mini-core since each core is individually custom fitted with a specific pin. If a special work pin is used with an alignment flat on its head, it must be oriented parallel to and on the same side as alignment flat on core.

To shorten the mini-core to a new length, the core is fixtured to the arbor using three set screws near the head of the core. The three collapsing segments must be held rigidly under a clamping ring located near the top of the core. See grinding set-up drawing for additional information. Then material is removed from the top (front) of the mini-core on a cylindrical grinder. The grinding wheel goes through the entire material of the mini-core segments and cuts into the arbor to insure a clean front surface. Remove burrs carefully but do not break any sharp corners, which would allow plastics material to form where it would interfere with collapse of the segments. The mini-cores collapse per side will be reduced by  $.020 \text{ in./in.} \times$  amount mini-core is shortened.

It is now obvious why an arbor or special work center pin is used. If this grinding was performed on the mini-core's regular center pin, the taper would be destroyed.

*When a mini-core has to be reground after its thread profiles have been finished and the centers on the regular pin have been removed, again an arbor or special center pin is used.*

The tapered end of the work arbor is inserted into the mini-core until the ground diameters of the mini-core coincide with those measured on the core with its regular center pin. The mini-core is fixtured on the work arbor with set screws and clamping ring as described above. It is now possible to change the diameters on the molding end of the mini-core segments, or to deepen or enlarge the thread profiles. If alterations are required that affect the O.D. of the center pin blades, a new custom fitted center pin may be required so that centers can be used to grind the mini-core and center pin uniformly.

After all finish grinding and polishing operations on the mini-core, it is important to demagnetize the core to prevent the adhesion of any metal particles which might find their way into cavities during molding.

# D-M-E COLLAPSIBLE MINI-CORE

## Mini-Core Grinding Set-Up Information

**Set-Up for O.D. Grinding of Mini-Core:** Refer to Grinding Instructions for additional information regarding O.D., thread and undercut grinding of core.

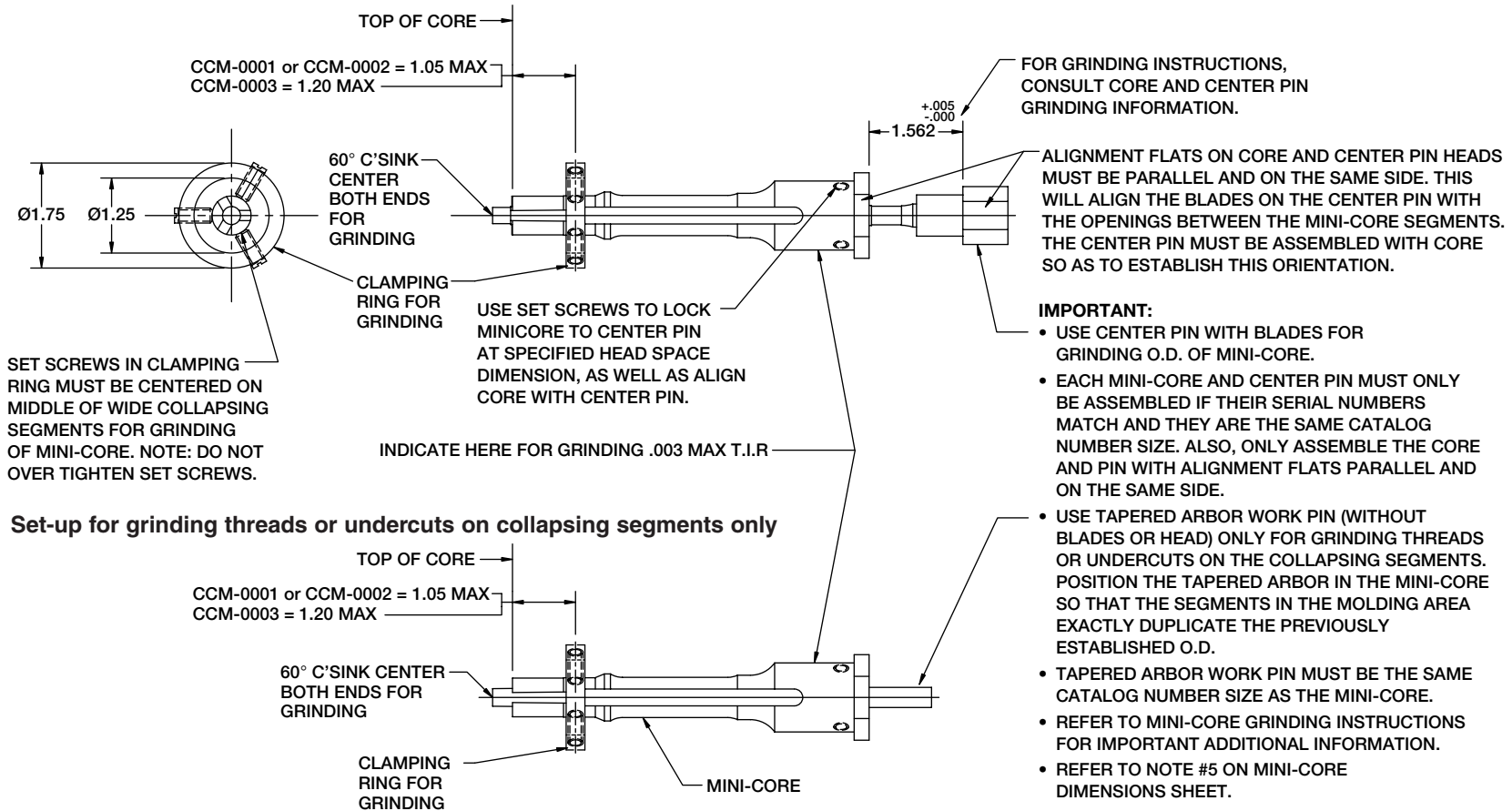

### NOTES:

1. Collapsible mini-core and center pin must be thoroughly cleaned prior to assembly for grinding.
2. Never use center pin with blades for grinding threads or undercuts.

Questions? Call D-M-E at 1-800-626-6653 (U.S.) • 1-800-387-6600 (Canada) • 32-15-215011 (Europe)

# D-M-E COLLAPSIBLE MINI-CORE

## CCM-0001 Mini-Core Dimensions

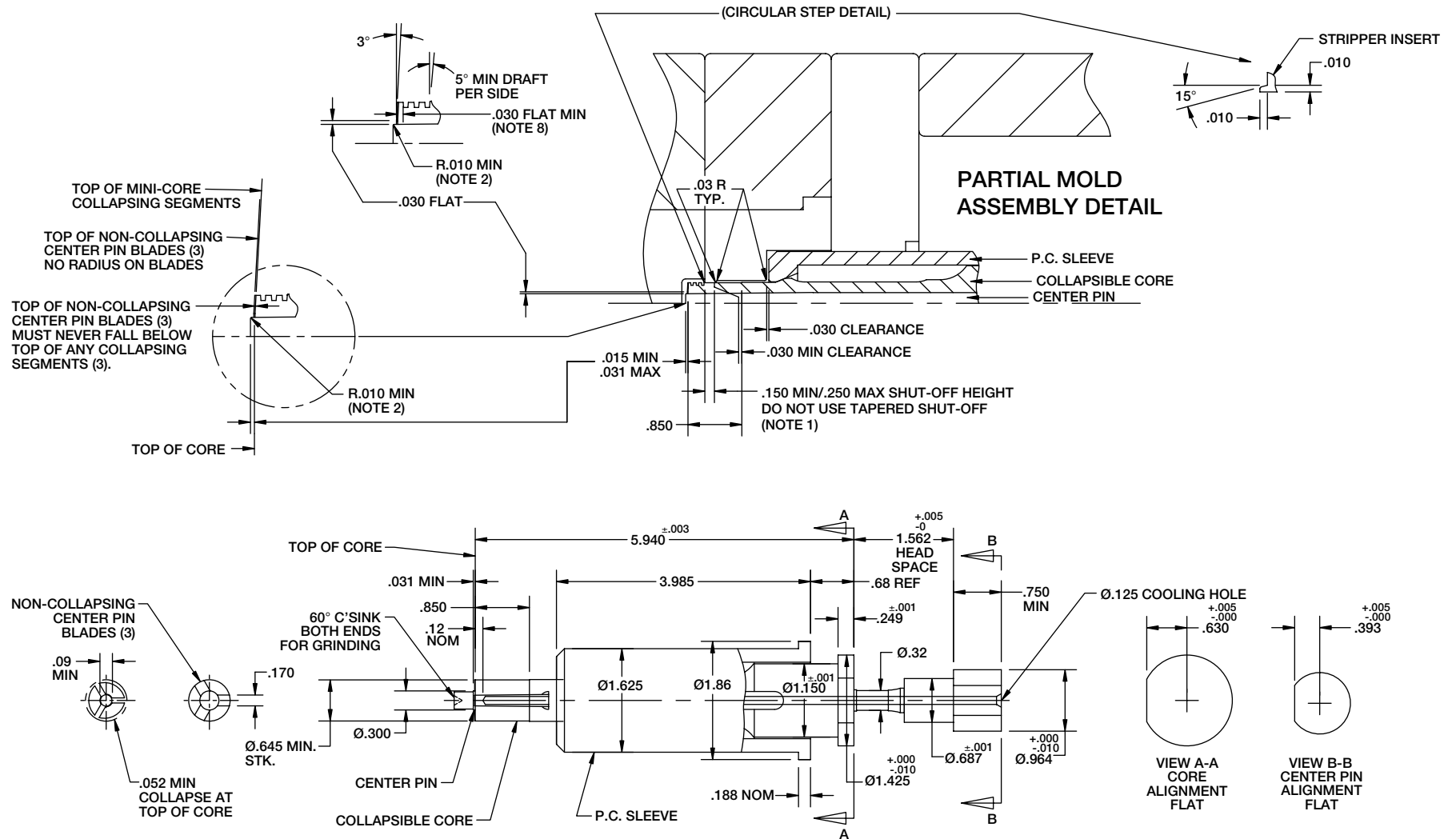

## D-M-E COLLAPSIBLE MINI-CORE

### CCM-0001 Mini-Core Dimensions (cont.)

#### NOTES:

1. Molding Length plus minimum core shut-off height of .150 should not exceed .850 except in special cores. (Contact D-M-E Applications Engineering Department for limitations regarding special core designs.)
2. Center pin diameter (.300 diameter at top of core) must protrude .015 minimum above top of core with .010 radius, as shown. See partial mold assembly detail.
3. Minimum suggested I.D. of thread or undercut is .425 to allow minimum steel support for segment between depth of undercut and I.D. of segment.
4. After finish grinding of core O.D. and shut-off diameter, but prior to assembly of core and center pin in mold; both ends of center pin are to be cut off. Use only tapered work arbor (with no head or blades) for grinding threads or undercuts in collapsing segments.
5. A 1.562 +.005/-.000 head space dimension must be held for core grinding. The head space dimension held in the mold base assembly is 1.562 +.000/-.005. These tolerances are intentionally different to assure that the top of the center blades never fall below the top of the core segments when installed in the mold. If this occurred, plastic material would be molded behind the core segments preventing them from collapsing, resulting in serious damage to the core.
6. For grinding instructions, consult core and center pin grinding information.
7. .031 radius is essential on inside corners of stripper plate insert, especially where shut-off contacts mini-core.
8. Thread must never run out the top of the core leaving a knife edge of steel that could break off. For instructions, refer to the design procedure section of the Mini-Core Tech Data Book.
9. Threads, undercuts and depressions can be ground into the (3) core segments. They must never be ground into the (3) non-collapsing center pin blades. Refer to the Core and Center Pin Grinding information for important instructions.
10. Non-collapsing center pin blades must have sharp corners in all areas. No broken edges or radii are permitted that could allow plastic material to form where it would interfere with the collapse of segments.
11. Do not use the center pin as a pilot into "A" half of mold.

# D-M-E COLLAPSIBLE MINI-CORE

## CCM-0001 Mini-Core Mold Base Machining Dimensions

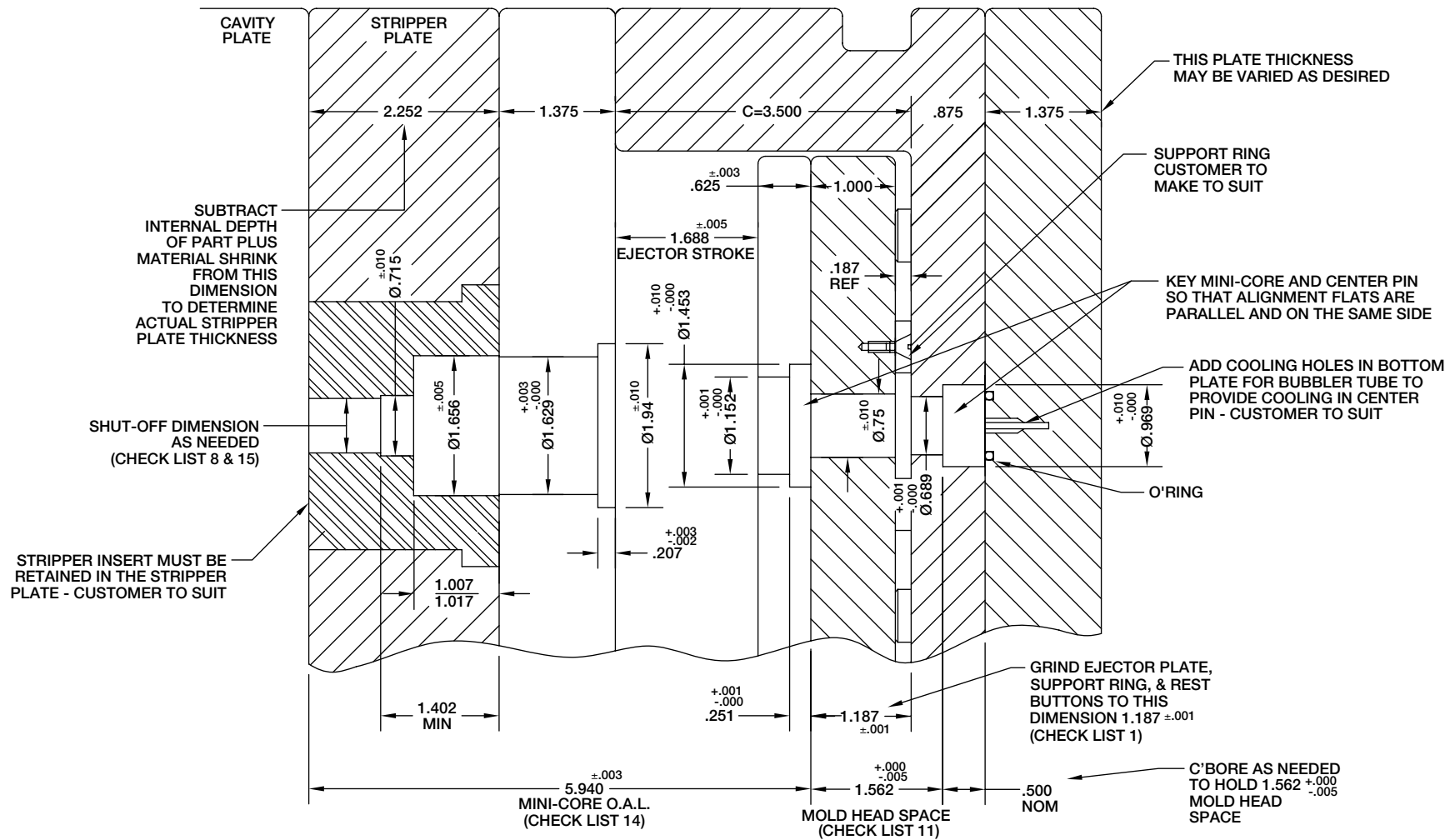



# D-M-E COLLAPSIBLE MINI-CORE

## CCM-0001 Mini-Core Mold Base Machining Dimensions (cont.)

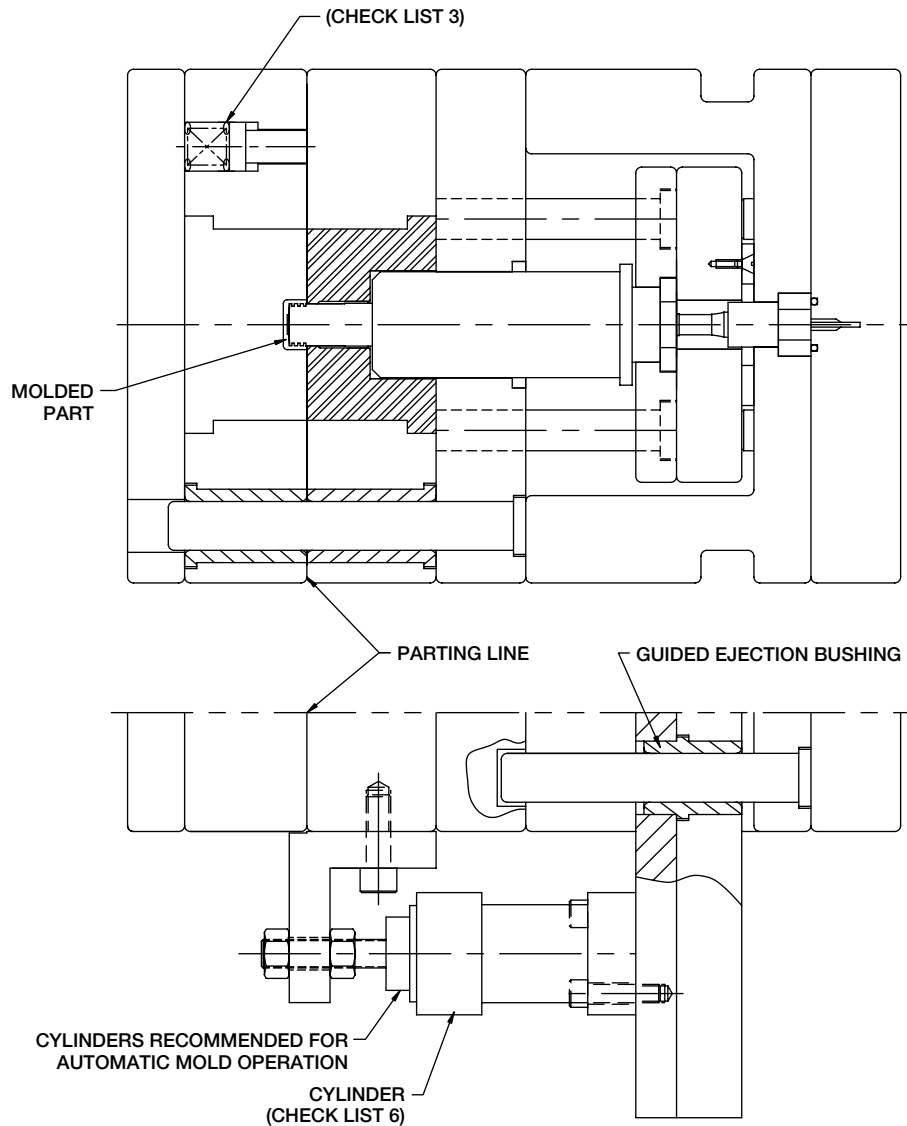

### Mold Design Check List

1. Use support ring around center pin. Ejector plate, support rings and rest buttons must be ground to  $1.187 \pm .001$ .
2. Always use guided ejection for ejector assembly. D-M-E guided ejection bushings locate ejector retainer plate and core with the rest of the mold.
3. Use springs to assure first break at main parting line. (Mold must open at main parting line prior to ejector assembly pushing stripper plate forward.)
4. Return pins to end under stripper plate. (Return pins must never run through the stripper plate.)
5. Ejector assembly must travel to full forward specification. Stamp  $1.688 \pm .005$  ejection stroke required on visible edge of mold plate.
6. Stripper plate actuation by cylinders to begin only after full ejector plate travel. Cylinders must return stripper plate fully before ejector plate begins return. It is recommended that the ejector assembly be held in its full forward position until the stripper plate is fully returned (see Sequence Description).
7. Good venting is essential, preferably to outside the mold. Do not vent part into core or center pin.
8. Clearance between core shut-off O.D. and stripper insert I.D. to be a total of  $.0010/.0015$ . Measure core when installed in mold. No tapered shut-off is permitted. Avoid excessive shut-off length;  $.150/.250$  is adequate.

Questions? Call D-M-E at 1-800-626-6653 (U.S.) • 1-800-387-6600 (Canada) • 32-15-215011 (Europe)

### CCM-0001 Mini-Core Mold Base Machining Dimensions (cont.)

#### Mold Design Check List (cont.)

9. Core must be located with a key in the ejector retainer plate (key to have about .005 clearance with alignment flat on core). This prevents the core from rotating and aligns it closely with the center pin to orient center pin blades between the core segments.
10. Center pin must be located with a key in the bottom of the housing (key to have about .005 clearance with alignment flat on pin). This prevents the pin from rotating and aligns it closely with the core to orient center pin blades between the core segments.

**NOTE:** Alignment of both keys for core and pin is essential for proper fit; they must be parallel and on the same side.

11. When core and pin are assembled in mold with 1.562  $\pm$ .000/-.005 head space dimension, check to make sure narrow blades on the center pin are never below the top of the collapsing segments.

**NOTE:** A recess of the narrow blades below the top of the core segments will result in core damage.

12. Center pin to be concentric with stripper bushing. Verify .015 pin protrusion beyond top of core and a minimum of .010 radius on tip of pin. Pin tip radius must always be slightly less than the pin protrusion to prevent plastic material from being formed behind the core segments. No radius permissible on center pin blades.
13. Positive collapse sleeve to travel freely through 'BX' support plate. Apply grease lightly to O.D. of positive collapse sleeve. Check for free movement when mold is at operating temperature.
14. When top of core segments shut-off against cavity (example, some parts with through holes), all cores must be ground to the same length (O.A.L.). The normal tolerance of  $\pm$ .003 is inadequate and may overload core. Refer to core grinding instructions. Clearance between top of core and cavity to be .0005 to .0010. Do not pre-load core. Whenever the above condition exists, an early ejector return system is mandatory.

**NOTE:** This applies only when top of collapsing core segments shut off against the cavity. Also, exercise care to avoid pre-load on center pin. A .0000 to .0015 interference is adequate. Also, whenever above condition exists, the head space dimension in the mold must be held to exactly what was used to grind the length (O.A.L.) for each core with a tolerance of  $\pm$ .0000 to  $\pm$ .0010. All cores must be set up for grinding with exactly the same head space using a tolerance of  $\pm$ .0010 to  $\pm$ .0000. This must be done to prevent the top of the blades on the center pin from ever falling below the top of the collapsing segments on the core, which would cause serious damage to the core if it occurred.

15. The stripper shut-off diameter must be the same or preferably a larger diameter than any other diameter on the core.



## D-M-E COLLAPSIBLE MINI-CORE

### CCM-0002 Mini-Core Dimensions (cont.)

#### NOTES:

1. Molding length plus minimum core shut-off height of .150 should not exceed .850, except in special cores. (Contact D-M-E Applications Engineering Department for limitations regarding special core designs).
2. Center pin diameter (.420 diameter at top of core) must protrude .015 minimum above top of core with .010 radius, as shown. See partial mold assembly detail.
3. Minimum suggested I.D. of thread or undercut is .560 to allow minimum steel support for segment between depth of undercut and I.D. of segment.
4. After finish grinding of core O.D. and shut-off diameter, but prior to assembly of core and center pin in mold; both ends of center pin are to be cut off. Use only tapered work arbor (with no head or blades) for grinding threads or undercuts in collapsing segments.
5. A  $1.562 +.005/-.000$  head space dimension must be held for core grinding. The head space dimension held in the mold base assembly is  $1.562 +.000/-.005$ . These tolerances are intentionally different to assure that the top of the center blades never fall below the top of the core segments when installed in the mold. If this occurred, plastic material would be molded behind the core segments preventing them from collapsing, resulting in serious damage to the core.
6. For grinding instructions, consult core and center pin grinding information for the Collapsible Mini-Core.
7. A .031 radius is essential on inside corners of stripper plate insert; especially where shut-off contacts mini-core.
8. Thread must never run out the top of the core leaving a knife edge of steel that could break off. For instructions, refer to the Design Procedure for the Collapsible Mini-Core.
9. Threads, undercuts and depressions can be ground into the (3) core segments. They must never be ground in the (3) non-collapsing center pin blades. Refer to the Core and Center Pin Grinding information for the Collapsible Mini-Core.
10. Non-collapsing center pin blades must have sharp corners in all areas. No broken edges or radii are permitted that could allow plastic material to form where it would interfere with the collapse of the segments.
11. Do not use the center pin as a pilot into "A" half of mold.



# D-M-E COLLAPSIBLE MINI-CORE

## CCM-0002 Mini-Core Mold Base Machining Dimensions (cont.)

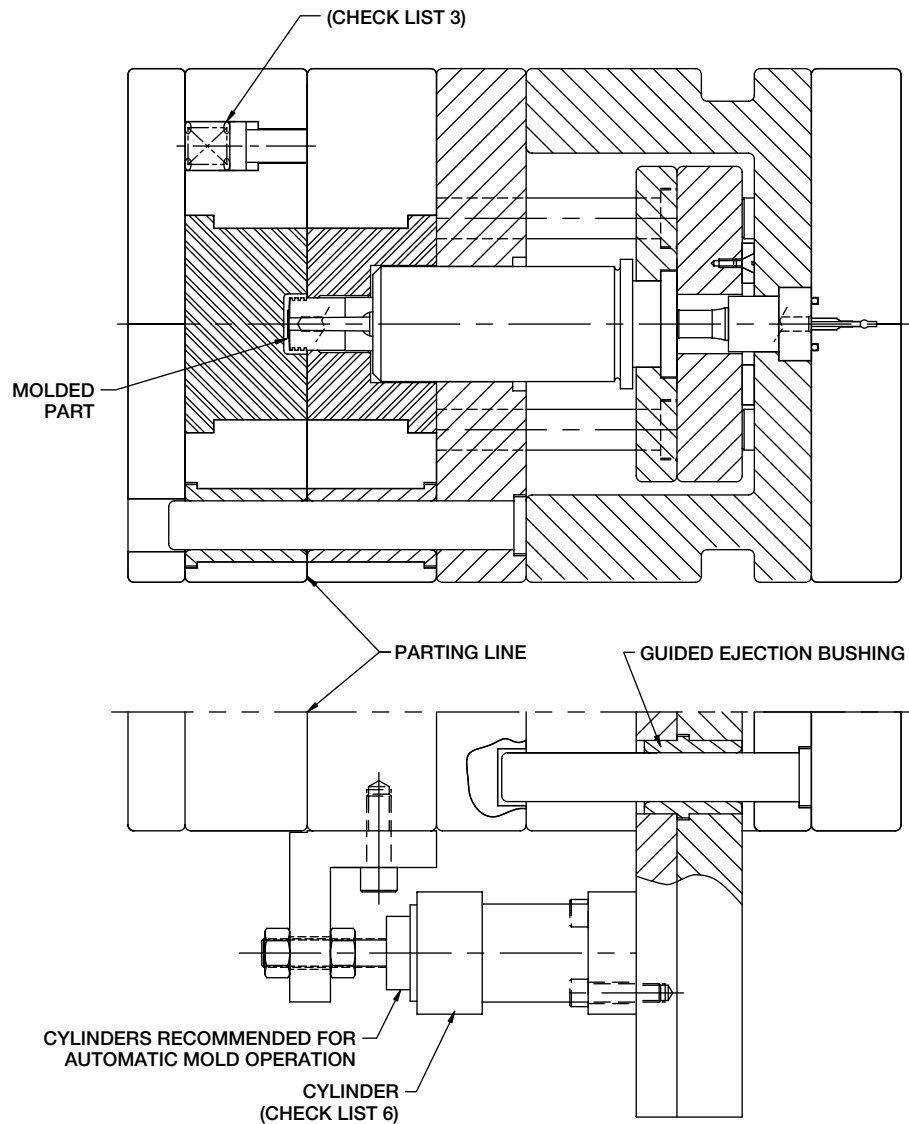

### Mold Design Check List

1. Use support ring around center pin. Ejector plate, support rings and rest buttons must be ground to  $1.187 \pm .001$ .
2. Always use guided ejection for ejector assembly. D-M-E guided ejection bushings locate ejector retainer plate and core with the rest of the mold.
3. Use springs to assure first break at main parting line. (Mold must open at main parting line prior to ejector assembly pushing stripper plate forward.)
4. Return pins to end under stripper plate. (Return pins must never run through the stripper plate.)
5. Ejector assembly must travel to full forward specification. Stamp  $1.688 \pm .005$  ejection stroke required on visible edge of mold plate.
6. Stripper plate actuation by cylinders to begin only after full ejector plate travel. Cylinders must return stripper plate fully before ejector plate begins return. It is recommended that the ejector assembly be held in its full forward position until the stripper plate is fully returned (see Sequence Description).
7. Good venting is essential, preferably to outside the mold. Do not vent part into core or center pin.
8. Clearance between core shut-off O.D. and stripper insert I.D. to be a total of  $.0010/.0015$ . Measure core when installed in mold. No tapered shut-off is permitted. Avoid excessive shut-off length;  $.150/.250$  is adequate.

### CCM-0002 Mini-Core Mold Base Machining Dimensions (cont.)

#### Mold Design Check List (cont.)

9. Core must be located with a key in the ejector retainer plate (key to have about .005 clearance with alignment flat on core). This prevents the core from rotating and aligns it closely with the center pin to orient center pin blades between the core segments.
10. Center pin must be located with a key in the bottom of the housing (key to have about .005 clearance with alignment flat on pin). This prevents the pin from rotating and aligns it closely with the core to orient center pin blades with the core segments.

**NOTE:** Alignment of both keys for core and pin is essential for proper fit, they must be parallel and on the same side.

11. When core and pin are assembled in mold with 1.562 +.000/-.005 head space dimension, check to make sure that narrow blades on the center pin are never below the top of the collapsing segments.

**NOTE:** A recess of the narrow blades below the top of the core segments will result in core damage.

12. Center pin to be concentric with stripper bushing. Verify .015 pin protrusion beyond top of core and a minimum of .010 radius on tip of pin. Pin tip radius must always be slightly less than the pin protrusion to prevent plastic material from being formed behind the core segments. No radius permissible on center pin blades.
13. Positive collapse sleeve to travel freely through "BX" support plate. Apply grease lightly to O.D. of positive collapse sleeve. Check for free movement when mold is at operating temperature.
14. When top of core segments shut-off against cavity (example, some parts with through holes), all cores must be ground to the same length (O.A.L.). The normal tolerance of  $\pm .003$  is inadequate and may overload core. Refer to core grinding instructions. Clearance between top of core and cavity to be .0005 to .0010. Do not pre-load core. Whenever the above condition exists, an early ejector return system is mandatory.

**NOTE:** This applies only when top of collapsing core segments shut off against the cavity. Also, exercise care to avoid pre-load on center pin. A .0000 to .0015 interference is adequate. Also, whenever above condition exists, the head space dimension in the mold must be held to exactly what was used to grind the length (O.A.L.) for each core with a tolerance of +.0000 to -.0010. All cores must be set up for grinding with exactly the same head space using a tolerance of +.0010 to -.0000. This must be done to prevent the top of the blades on the center pin from ever falling below the top of the collapsing segments on the core, which would cause serious damage to the core if it occurred.

15. The stripper shut-off diameter must be the same or preferably a larger diameter than any other diameter on the core.

# D-M-E COLLAPSIBLE MINI-CORE

## CCM-0003 Mini-Core Dimensions

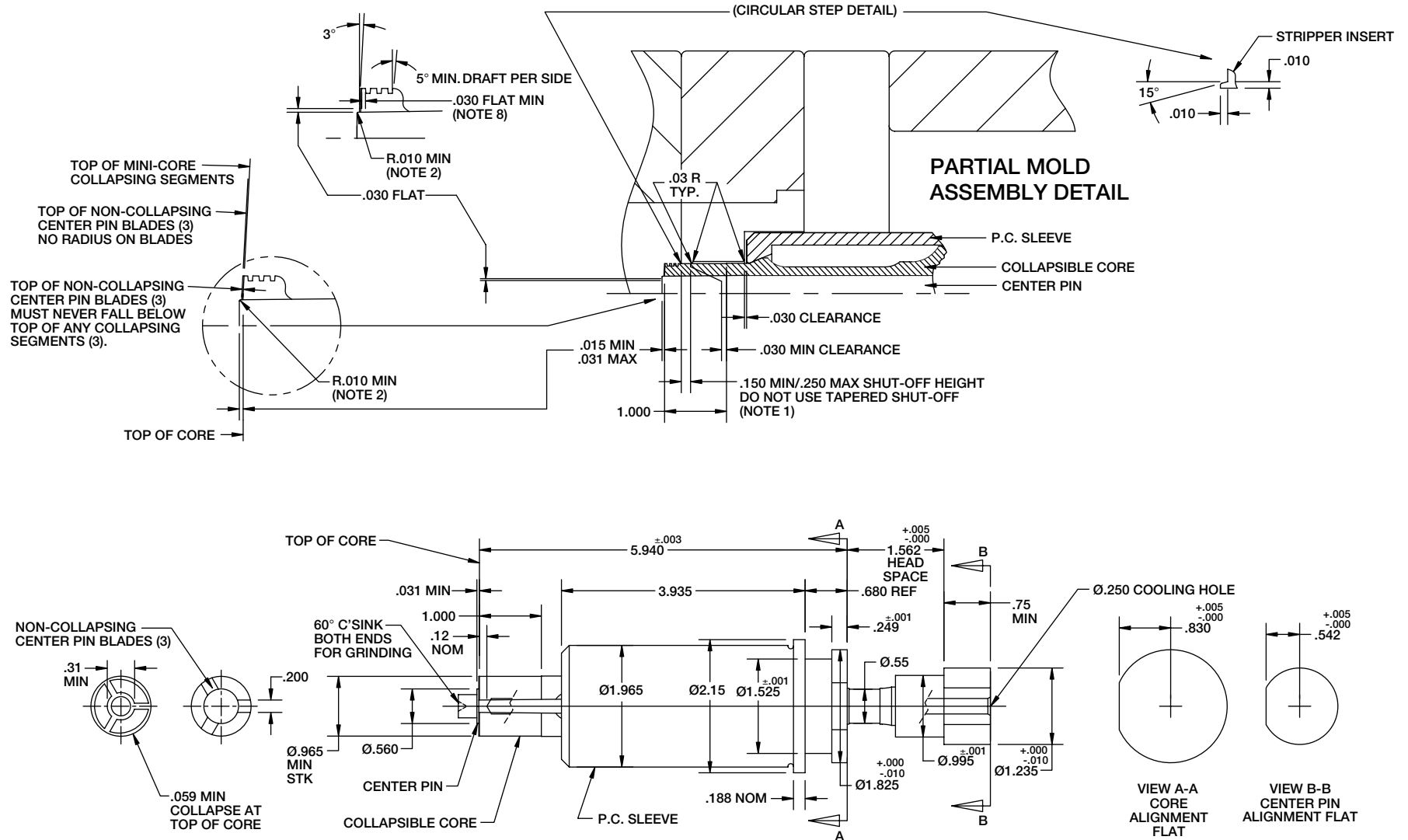



## D-M-E COLLAPSIBLE MINI-CORE

### CCM-0003 Mini-Core Dimensions (cont.)

#### NOTES:

1. Molding length plus minimum core shut-off height of .150 should not exceed 1.000, except in special cores. (Contact D-M-E Applications Engineering Department for limitations regarding special core designs).
2. Center pin diameter (.560 diameter at top of core) must protrude .015 minimum above top of core with .010 radius, as shown. See partial mold assembly detail.
3. Minimum suggested I.D. of thread or undercut is .710 to allow minimum steel support for segment between depth of undercut and I.D. of segment.
4. After finish grinding of core O.D. and shut-off diameter, but prior to assembly of core and center pin in mold, both ends of center pin are to be cut off. Use only tapered work arbor (with no head or blades) for grinding threads or undercuts in collapsing segments.
5. A 1.562 +.005/-.000 head space dimension must be held for core grinding. The head space dimension held in the mold base assembly is 1.562 +.000/-.005. These tolerances are intentionally different to assure that the top of the center blades never fall below the top of the core segments when installed in the mold. If this occurred, plastic material would be molded behind the core segments preventing them from collapsing, resulting in serious damage to the core.
6. For grinding instructions, consult core and center pin grinding information for the Collapsible Mini-Core.
7. .031 radius is essential on inside corners of stripper plate insert, especially where shut-off contacts mini-core.
8. Thread must never run out the top of the core leaving a knife edge of steel that could break off. For instructions, refer to the Design Procedure for the Collapsible Mini-Core.
9. Threads, undercuts and depressions can be ground into the (3) core segments. They must never be ground into the (3) non-collapsing center pin blades. Refer to the Core and Center Pin Grinding instructions for the Collapsible Mini-Core.
10. Non-collapsing center pin blades must have sharp corners in all areas. No broken edges or radii are permitted that could allow plastic material to form where it would interfere with the collapse of the segments.
11. Do not use the center pin as a pilot into "A" half of mold.



# D-M-E COLLAPSIBLE MINI-CORE

## CCM-0003 Mini-Core Mold Base Machining Dimensions (cont.)

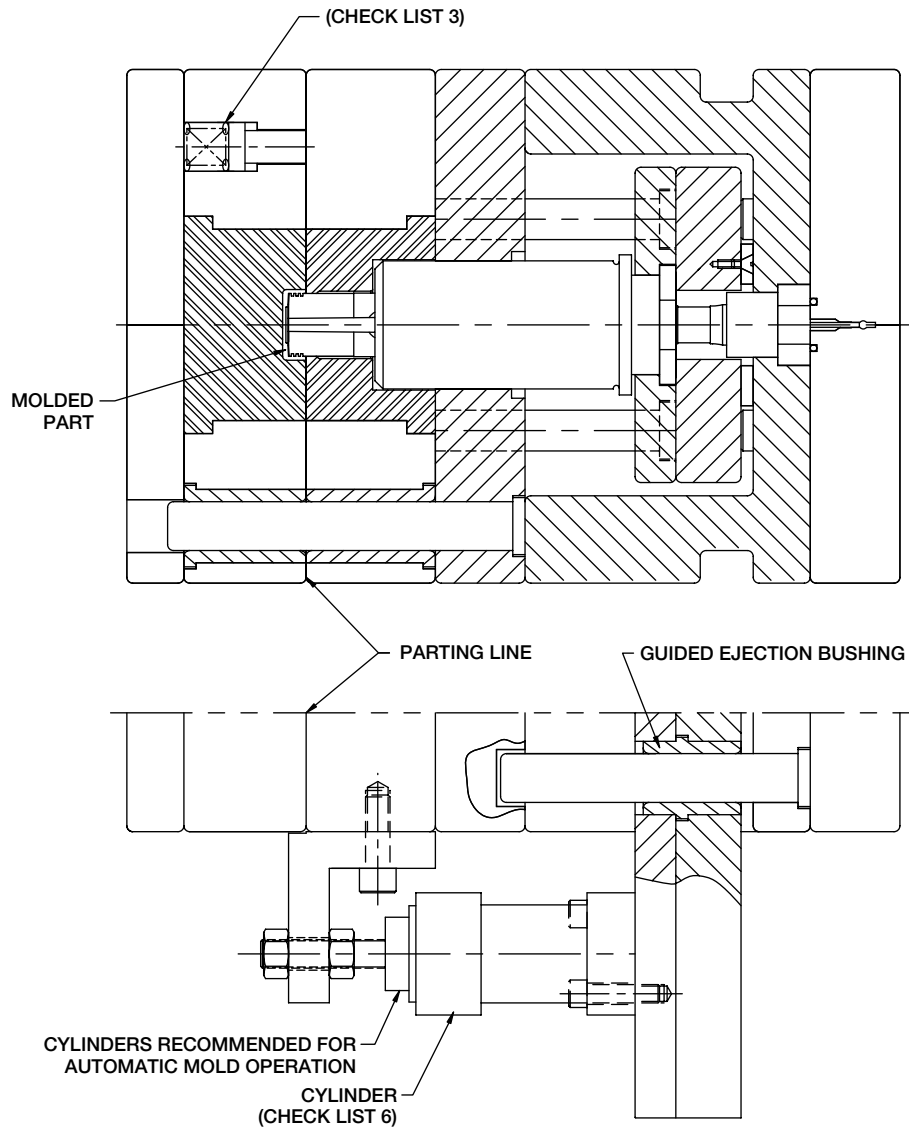

### Mold Design Check List

1. Use support ring around center pin. Ejector plate, support rings and rest buttons must be ground to  $1.187 \pm .001$ .
2. Always use guided ejection for ejector assembly. D-M-E guided ejection bushings locate ejector retainer plate and core with the rest of the mold.
3. Use springs to assure first break at main parting line. (Mold must open at main parting line prior to ejector assembly pushing stripper plate forward.)
4. Return pins to end under stripper plate. (Return pins must never run through the stripper plate.)
5. Ejector assembly must travel to full forward specification. Stamp  $1.688 \pm .005$  ejection stroke required on visible edge of mold plate.
6. Stripper plate actuation by cylinders to begin only after full ejector plate travel. Cylinders must return stripper plate fully before ejector plate begins return. It is recommended that the ejector assembly be held in its full forward position until the stripper plate is fully returned (see Sequence Description).
7. Good venting is essential, preferably to outside the mold. Do not vent part into core or center pin.
8. Clearance between core shut-off O.D. and stripper insert I.D. to be a total of  $.0010/.0015$ . Measure core when installed in mold. No tapered shut-off is permitted. Avoid excessive shut-off length;  $.150/.250$  is adequate.

Questions? Call D-M-E at 1-800-626-6653 (U.S.) • 1-800-387-6600 (Canada) • 32-15-215011 (Europe)

### CCM-0003 Mini-Core Mold Base Machining Dimensions (cont.)

#### Mold Design Check List (cont.)

9. Core must be located with a key in the ejector retainer plate (key to have about .005 clearance with alignment flat on core). This prevents the core from rotating and aligns it closely with the center pin to orient center pin blades between the core segments.
10. Center pin must be located with a key in the bottom of the housing (key to have about .005 clearance with alignment flat on pin). This prevents the pin from rotating and aligns it closely with the core to orient center pin blades between the core segments.

**NOTE:** Alignment of both keys for core and pin is essential for proper fit, they must be parallel and on the same side.

11. When core and pin are assembled in mold with 1.562 +.000/-.005 head space dimension, check to make sure that narrow blades on the center pin are never below the top of the collapsing segments.

**NOTE:** A recess of the narrow blades below the top of the core segments will result in core damage.

12. Center pin to be concentric with stripper bushing. Verify .015 pin protrusion beyond top of core and a minimum of .010 radius on tip of pin. Pin tip radius must always be slightly less than the pin protrusion to prevent plastic material from being formed behind the core segments. No radius permissible on center pin blades.
13. Positive collapse sleeve to travel freely through "BX" support plate. Apply grease lightly to O.D. of positive collapse sleeve. Check for free movement when mold is at operating temperature.
14. When top of core segments shut off against the cavity (example, some parts with through holes), all cores must be ground to the same length (O.A.L.). The normal tolerance of  $\pm .003$  is inadequate and may overload the core. Refer to core grinding instructions. Clearance between top of core and cavity to be .0005 to .0010. Do not pre-load core. Whenever the above condition exists, an early ejector return system is mandatory.

**NOTE:** This applies only when top of collapsing core segments shut off against the cavity. Also, exercise care to avoid pre-load on center pin. A .0000 to .0015 interference is adequate. Also, whenever above condition exists, the head space dimension in the mold must be held to exactly what was used to grind the length (O.A.L.) for each core with a tolerance of +.0000 to -.0010. All cores must be set up for grinding with exactly the same head space using a tolerance of +.0010 to -.0000. This must be done to prevent the top of the blades on the center pin from ever falling below the top of the collapsing segments on the core, which would cause serious damage to the core if it occurred.

15. The stripper shut-off diameter must be the same or preferably a larger diameter than any other diameter on the core.

## Collapsible Mini-Core Stripper Plate Mold Base

# ORDERING GUIDE

For CCM-0001, CCM-0002, CCM-0003

### When Ordering:

1. Specify five-plate series special stripper plate mold base.
2. Specify "AX" plate thickness as needed.
3. Specify "X" plate thickness as required. Refer to mold base machining dimensions drawings for instructions to determine "X" (stripper plate) thickness.
4. Under "Special notes" request:
  - a. Ejector retainer plate  $.625 \pm .003$  thick.
  - b. Ejector plate 1.00 thick.
  - c. Cumulative height of ejector plate and rest buttons to be  $1.187 \pm .001$ .
  - d. "BX" plate is to be  $1.375 \pm .001$  thick.
  - e. Leader pin length must be sufficient to allow full forward ejection actuated travel of stripper plate, plus additional travel of stripper plate by cylinders required for part ejection.
5. Specify location, type size and number of guided ejection bushings and pins.
6. Specify standard length of ejector plate "E" as required for mounting cylinders.

# D-M-E COLLAPSIBLE MINI-CORE

## Ordering Guide – Collapsible Mini-Core Stripper Plate Mold Base

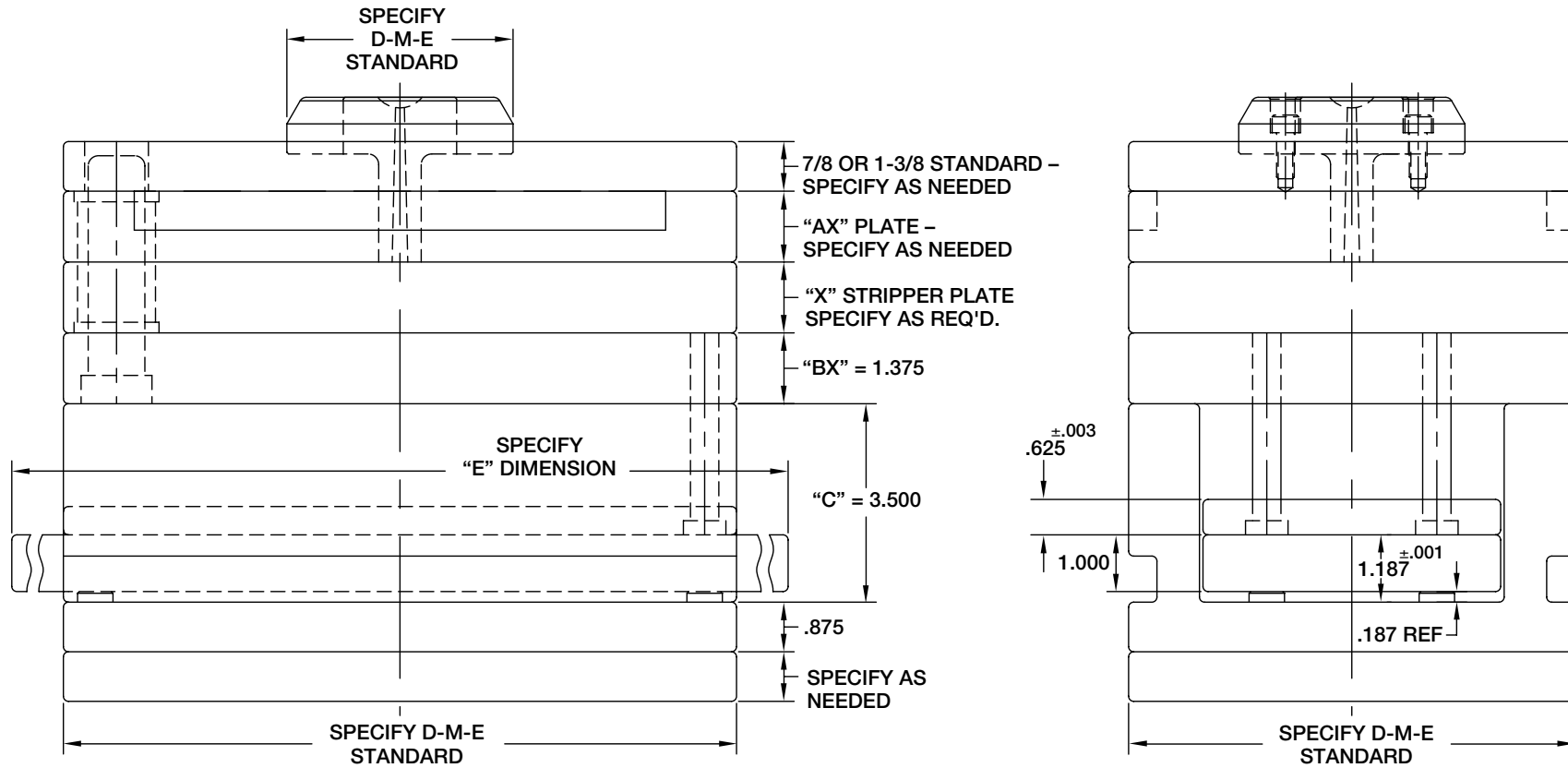

**World Headquarters**

**D-M-E Company**

29111 Stephenson Highway  
Madison Heights, MI 48071  
800-626-6653 *toll-free tel*  
248-398-6000 *tel*  
888-808-4363 *toll-free fax*  
www.dme.net *web*  
info@dme.net *e-mail*

**D-M-E of Canada, Ltd.**

6210 Northwest Drive  
Mississauga, Ontario  
Canada L4V 1J6  
800-387-6600 *toll-free tel*  
905-677-6370 *tel*  
800-461-9965 *toll-free fax*  
dme\_canada@dme.net *e-mail*

**D-M-E Europe**

D-M-E Belgium C.V.B.A.  
Industriepark Noord  
B-2800 Mechelen  
Belgium  
32-15-215011 *tel*  
32-15-218235 *fax*  
sales@dmeeu.com *e-mail*

