

Shut-Off Nozzle

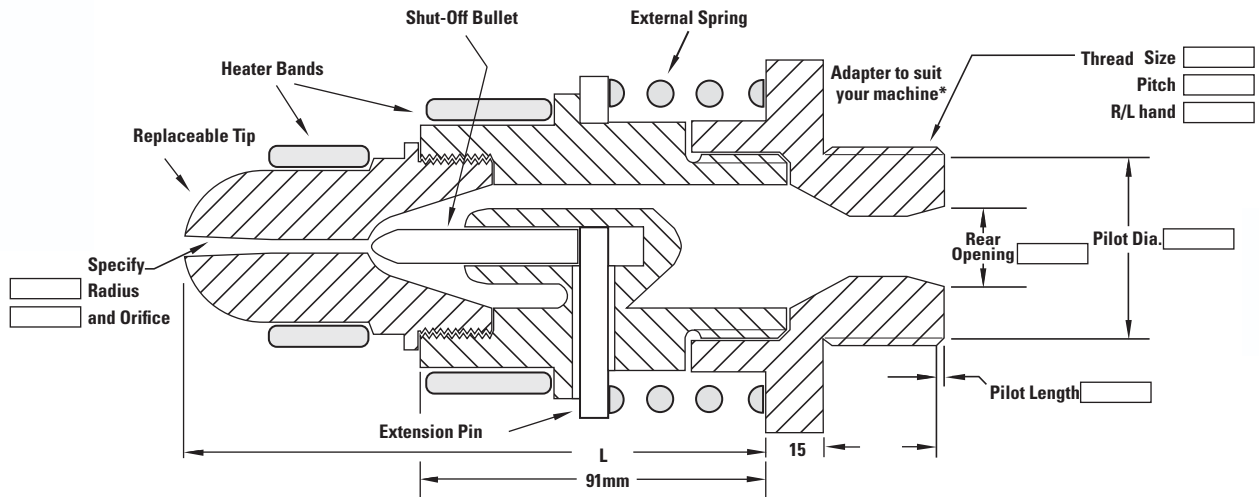

Please email completed form to: dmeus-csspecials@dme.net



Shut-Off Nozzle

Includes complete assembly (Body, Tip, External Spring, Shut-Off Pin, Pin Extension, and Adapter to suit your machine)

Description

Threads up to 2" (50mm) diameter

Threads over 2" to 2 3/4" (50mm to 70mm) dia.

Replacement Parts

Description	Part Number
External Spring	SPG2A
Shut-Off Pin	
1" length	OPSOPA
2" length	OPSOP2
3" length	OPSOP3
Adapter up to 50mm to suit your machine	SOADA*
Nozzle Tips	
Style A	FT1
Style B	FT2
Style C	FT3

How to Order

1. Complete information on drawing above
2. Specify tip length or style (FT1, FT2 or FT3)
3. Specify radius and orifice of tip

*Identify thread detail, thread length and rear opening.

Company: _____
 Account Number: _____
 Address: _____
 City: _____
 State/Zip: _____

Contact Name: _____
 Phone: _____
 Fax: _____
 E-mail: _____