



Custom Sprue Bushing Quote Request Form

Email completed form to:
dmeus-csspecials@dme.net



Company name: _____	DME Acct #: _____
Contact name: _____	Job #: _____
Phone: _____	Fax #: _____
Address: _____	E-mail: _____
City: _____	State: _____
ZIP: _____	Country: _____

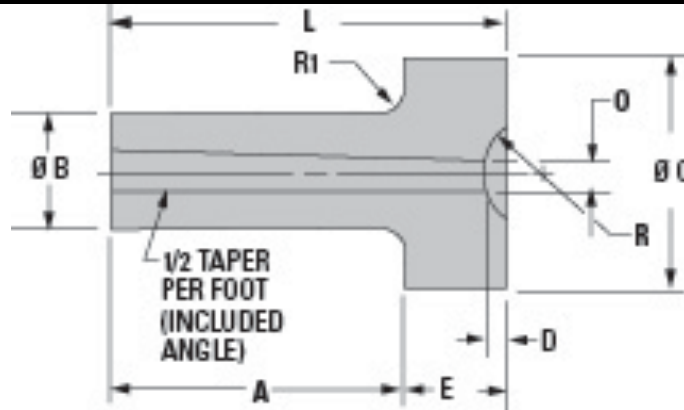

Call out	Required Dimension
A (Stem Length)	
B (Stem Diameter)	
C (Head Diameter)	
D (Radius Depth)	
E (Head Thickness)	
L (Length)	
O (Orifice)	
R (Radius)	
R1 (Radius Under Head)	
<input type="checkbox"/> Standard Material – SAE 6145 43-45 HRC	
<input type="checkbox"/> LN Series SAE 6145 Carburized .050-.060 deep 60-62 HRC	
<input type="checkbox"/> Other	
<i>All dimensions & material must be specified for quoting</i>	
Quantity	

Comments

For additional work, contact Customer Service at 800-626-6653

Special sprue bushing doc.