

Stellar 7000



STELLAR 7000 HOT RUNNER.

WHY THE STELLAR 7000?

- Provides the ability for DME to offer a Stellar Manifold & Components alternative, for customers who want to do their own hot half plate machining.
- Larger head provides the ability to incorporate a seal-ring, which minimizes the chance of a nozzle to manifold leak.
- Will work with 1.000" minimum drop to drop spacing.
- Uses current Stellar 5000-series embedded nozzle heaters for interchangeability.
- Uses current Stellar 5000-series bodiless point gate design, both standard and wear-resistant, for interchangeability.
- Includes (2) new sprue tip offerings, with 10mm and .750" T-diameters.
- Available in 6 lengths, ranging from 45mm to 145mm A-dimensions.
- Unique dual-key head design allows easier machining of nozzle plate and installation.
- Upgrade current Stellar 5000 series bodies to the new and improved 7000 series bodies for optimal performance and system integrity



STELLAR 7000 HOT RUNNER NOZZLES AND TIPS

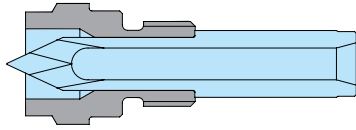

Standard Point Gate Tip Sub-Assembly, SXG5110

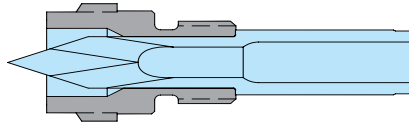

High Performance Point Gate Tip Sub-Assembly, SXG5020

TIP SUB-ASSEMBLY ITEM NUMBER	DESCRIPTION	TIP ITEM NUMBER	RETAINER ITEM NUMBER	GATING STYLE	RESIN TYPE	FOR USE WITH TEMPERATURES
SXG5110	Standard Point Gate Tip Sub-Assembly	SXT4010	SXF5100	Point Gate	Unfilled Commodity	up to 290°C (550°F)
SXG5020	High Performance Point Gate Tip Sub-Assembly	SXT5010	SXF5000	Point Gate	Filled / Engineering	up to 330°C (625°F)

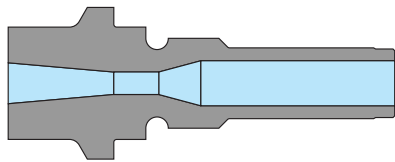

Standard 10mm Sprue Gate Tip, SXT7040

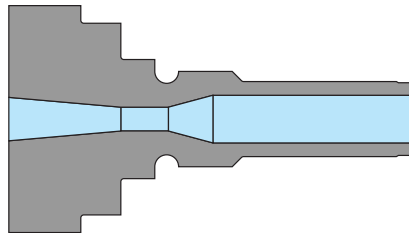

Standard .750" Sprue Gate Tip, SXT7140

TIP ITEM NUMBER	DESCRIPTION	GATING STYLE
SXT7040	10mm Sprue Gate Tip	Sprue Gate
SXT7140	.750" Sprue Gate Tip	Sprue Gate

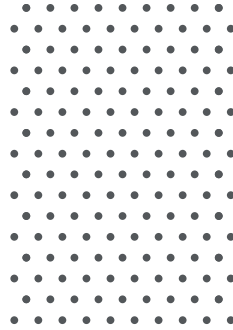

SXG5110 / SXG5020 Point Gate Tip Machining Details

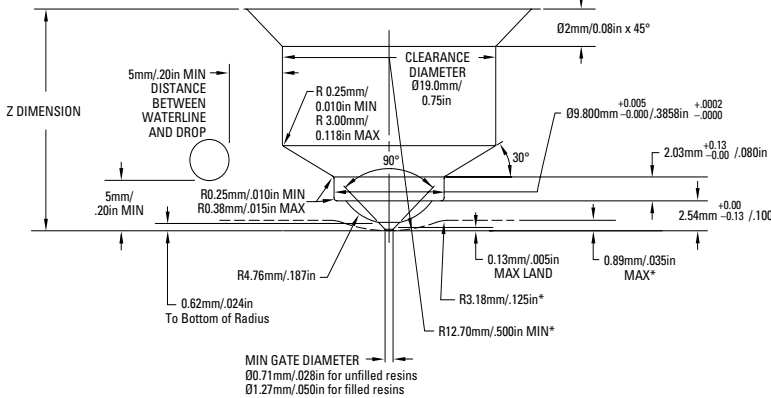

SXT7040 / SXT7140 Sprue Gate Tip Machining Details

