



GRANULATORS

GRANULATORS

DRG Series

Standard Features

- Infeed hopper specifically designed for beside-the-press manual or robot-fed loading
- No sizing screen (screenless)
- Clear-view hopper design allows operator to see the material being processed
- Automatic reversing system is standard for reversing the rotation of the rotor to easily clear any material obstruction
- Integrated metal detection is internal to the machine to help prevent metal contamination
- Equipped with an emergency stop button
- Quiet operation (70-80 dB)
- Energy saving low horsepower
- Uniform granule size
- Heavy-duty construction
- No special tools required to open the granulator
- D2 crusher blades and cutting wheel
- Multiple safety interlocks prevent injury by restricting access to the granulator while operating
- Compact and mobile, caster mounted base saves valuable floor space and provides greater versatility



Dimensions and Features

| Item No | Cutting Chamber Opening | Motor HP | Crusher Blades | Cutter Wheel Segments | Throughput lbs/hr | A | B | C | D |
|---------|----------------------------------|----------|----------------|-----------------------|-------------------|--------------------|--------------------|---------------------|----------------------|
| DRG79 | 8.7" x 6.9" (223 mm x 265 mm) | 3 | 1 | 2 | Up to 15lbs/hr | 13.38" (340 mm) | 13.58" (345 mm) | 50.19" (1275 mm) | 46.53" (1,182 mm) |
| DRG910 | 9" x 10.4" (228 mm x 265 mm) | 3 | 2 | 3 | Up to 20lbs/hr | 13.5" (342 mm) | 17.6" (448 mm) | 52.1" (1,325 mm) | 50.2" (1,276 mm) |
| DRG914 | 9" x 14.1" (228 mm x 359 mm) | 3 | 3 | 4 | Up to 30lbs/hr | 13.45" (341 mm) | 19.75" (502 mm) | 58" (1,473 mm) | 54" (1,370 mm) |
| DRG917 | 9" x 17.8" (228 mm x 453 mm) | 3 | 4 | 5 | Up to 40lbs/hr | 13.5" (345 mm) | 27" (691 mm) | 57.7" (1,466 mm) | 57.6" (1,466 mm) |

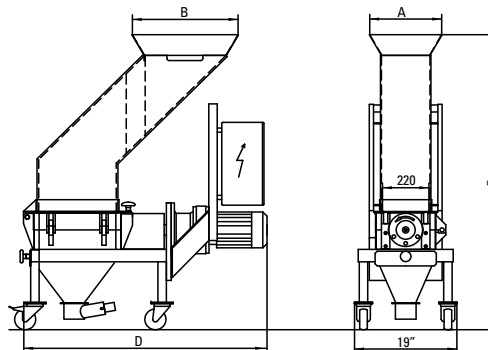

GRANULATORS

DSG Series



Standard Features:

- Staggered Rotor
- Hardened cutting chamber
- Cassette Knives
- No knife starters
- D2 tool steel knives
- Allen-Bradey starters
- Safety interlocks
- Low infeed height
- Scissor cut action knives
- Solid rotor pulley
- Rotating end disc
- Caster Mounted (Neoprene)
- Low RPM motor
- Reversible screen
- Removable flaps
- Tilt-back hopper
- Drop-down screen cradle
- Sound-proofed hopper

| Item No | HP | A | B |
|---------|-----------|--------|-------|
| DSG69 | 3 HP | 6 x 9 | 13.75 |
| DSG614 | 3 HP, 5HP | 6 x 14 | 19.5 |
| DSG617 | 3 HP, 5HP | 6 x 17 | 22.5 |

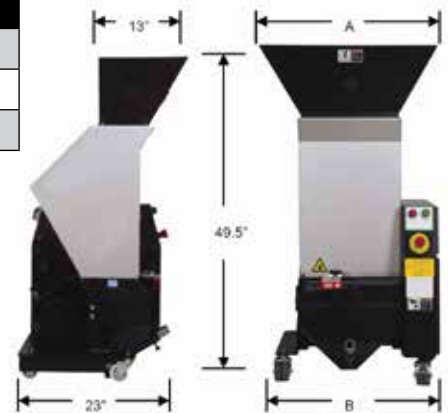

DSFG814 Series



Item No
DSFG814

Standard Features:

- 8" x 14" cutting chamber
- 7.5 HP motor
- Staggered rotor
- Cassette Knives
- No knife adjustment
- D2 tool steel knives
- Allen-Bradey starters
- Safety interlocks
- Low infeed height
- Scissor cut action knives
- Solid rotor pulley
- Rotating end disc
- Caster Mounted
- Low RPM motor
- Reversible screen
- Removable flaps
- Tilt-back hopper
- Drop-down screen cradle

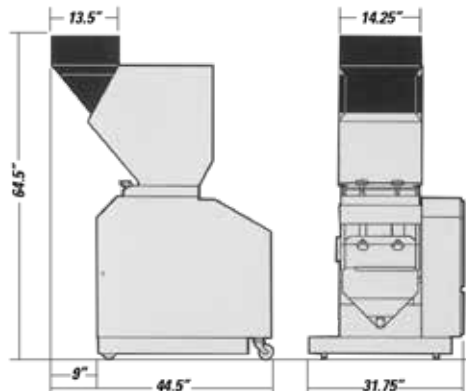

GRANULATORS

DFG Series

Standard Features

- Staggered rotor
- Cassette Knives
- No knife adjustment
- D2 tool steel knives
- Low infeed height
- Scissor cut action knives
- Flywheel type pulley
- Rotating end disc
- Low RPM motor
- Reversible screen
- Removable flaps
- Tilt-back hopper
- Drop-down screen cradle
- TEFC motor
- Redundant safety switches
- Low noise level
- Oversized sealed bearings
- Compact design - minimum floor footprint



| Item No | A | B |
|---------|-------|--------|
| DFG810 | 27" | 9.5" |
| DFG814 | 32" | 14.25" |
| DFG819 | 36" | 19" |
| DFG824 | 40.5" | 23.6" |

| | DFG810 | DFG814 | DFG819 | DFG824 |
|--------------------------|-----------|----------|----------|----------|
| Rotor Diameter (in) | 7.8" | 7.8" | 7.8" | 7.8" |
| Cutterhouse opening (in) | 8" x 9.5" | 8" x 14" | 8" x 19" | 8" x 24" |
| Capacity (lbs/hr.) | 0-150 | 0-225 | 0-350 | 0-500 |

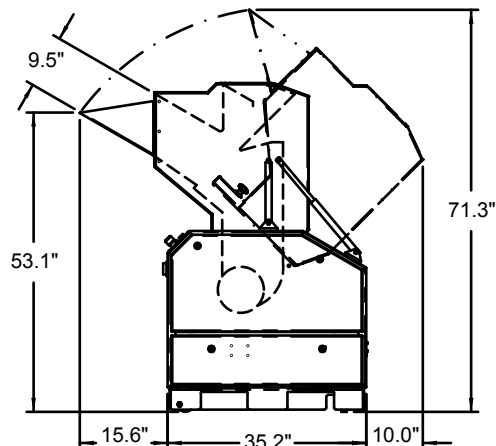
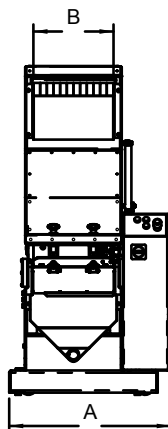

With tens of thousands of products to choose from, DME is your one-stop shop for everything molding. From complex undercut solutions and plate control to standard pins, bushings, and interlocks, the DME line of mold components will help you build or rebuild your mold base comprehensively. Industrial Supplies, Mold Bases, MUD Quick-Change, Control Systems, and Hot Runner solutions round out our extensive offering to truly be your one-stop shop.



www.store.dme.net



World Headquarters

DME Company LLC

29111 Stephenson Highway
Madison Heights, MI 48071

800-626-6653 *toll-free tel*

248-398-6000 *tel*

www.DME.net *web*

DME@DME.net *e-mail*

DME Canada

5345 Outer Drive - Unit 3
Oldcastle, Ontario
Canada N9G 0C4

800-387-6600 *toll-free tel*

905-677-6370 *tel*

DME_Canada@DME.net *e-mail*

DME Mexico / South America

Circuito el Marques Notre, No.55
Parque Industrial El Marqués
El Marqués, Querétaro, CP 76246

52.442.713.5666 *tel*

DME_Mexico@DME.net

eSTORE
www.dme.net/estore
Shop online 24/7.