

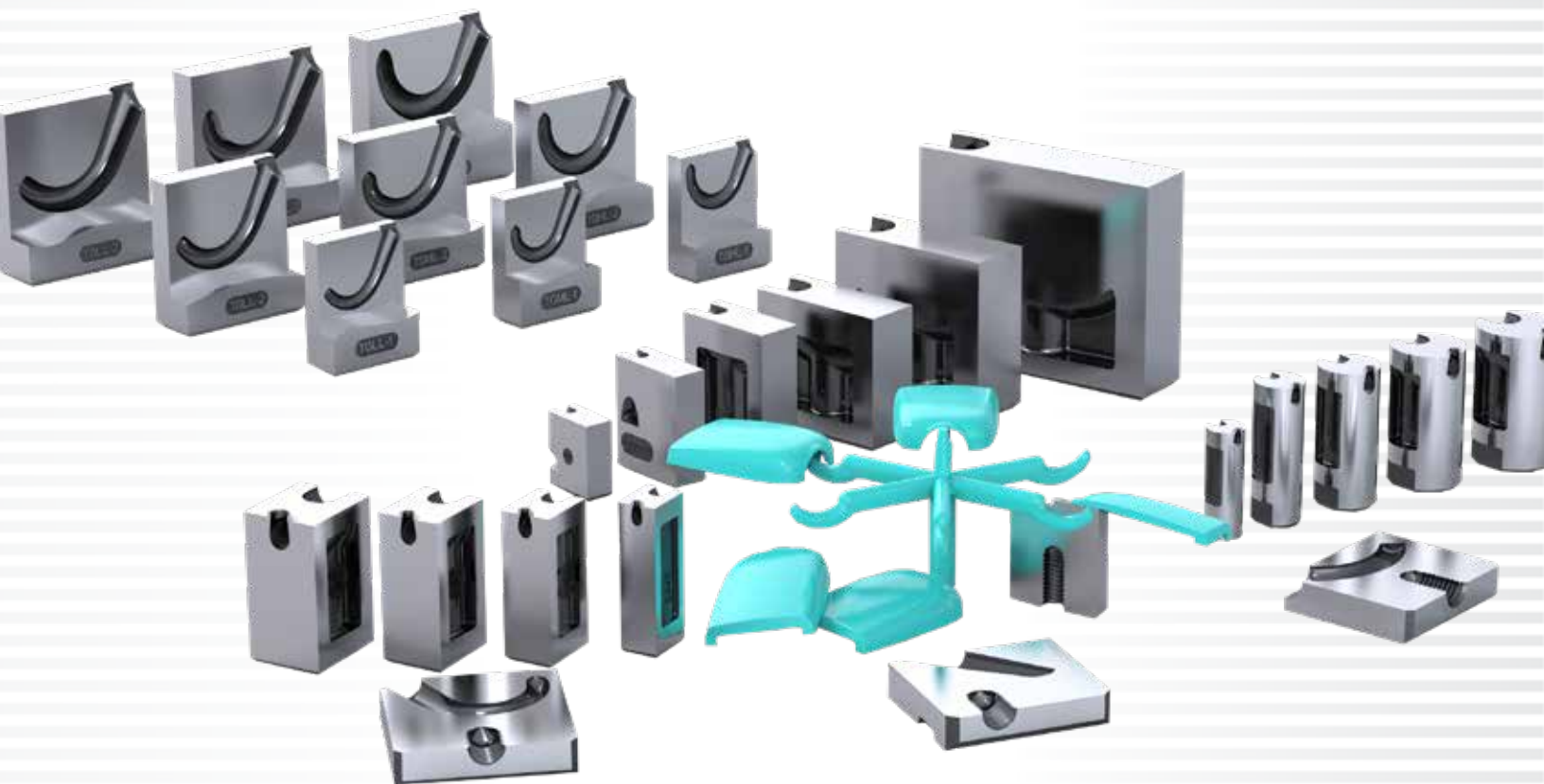

**GATE INSERTS
THE INTELLIGENT
SOLUTION**



OVERVIEW

**Standard
Version S2**

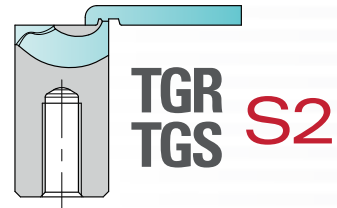
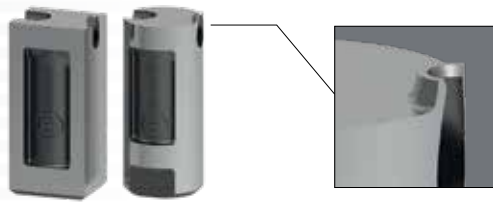

**TGR
TGS** **S2**

Pages 6-8

**Standard
Version S1**

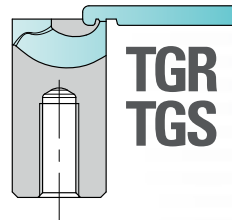
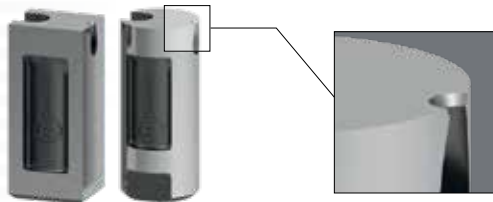

**TGR
TGS** **S1**

Pages 9-11

Contourable

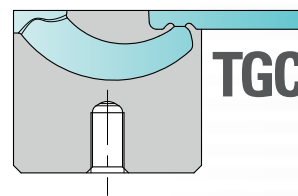
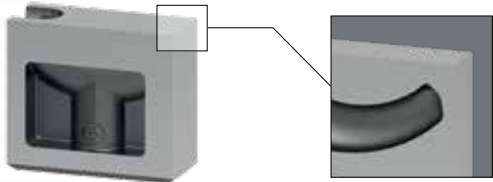

TGC

Pages 12-13

Contourable

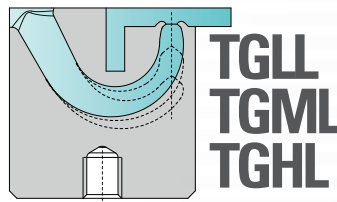
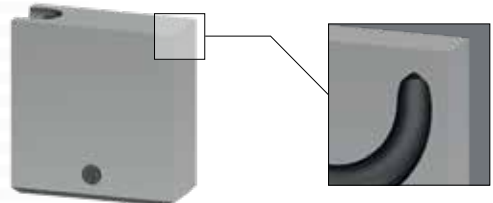

**TGLL
TGML
TGHL**

Pages 14-17

Side Gating

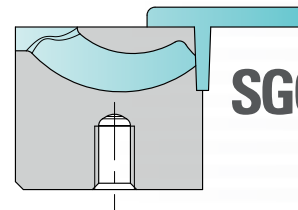
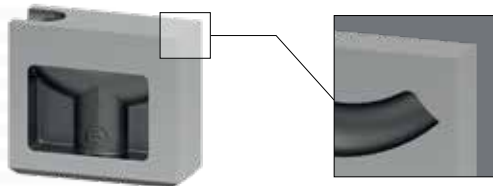

SGC

Pages 18-20

Tunnel Gating

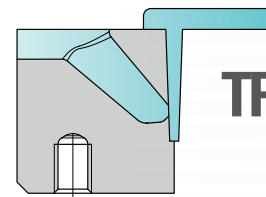
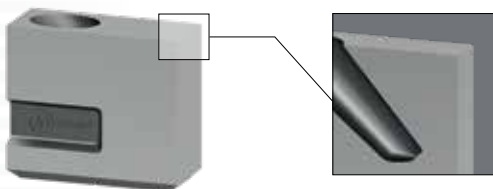

TPS

Pages 21-23

**Retaining
Bushing**

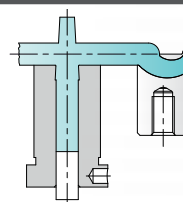
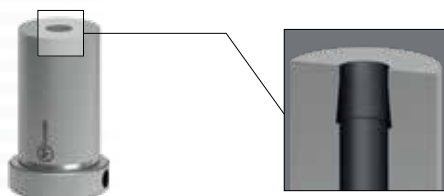

Page 24



INTRODUCTION

Tunnel gate inserts from DME are recognized worldwide as innovative products with high cost-reducing potential for moldmakers and molders.

- Fast and Easy Application = Time and Cost Reduction
- Made of highly wear-resistant hot work tool steel M2 (1.3343)
- High degree of reliability in production process
- Invisible gate marks through underside gating
- Integrated cutting edge for exact sprue separation
- Single-part design for compact dimensions
- Available in many different versions and sizes
- Suitable for all plastics due to optimized feed channel geometry – up to 60% filler content (e.g. glass fiber) is possible
- Use of MiM process ensures smooth feed channels and exact gate sizes

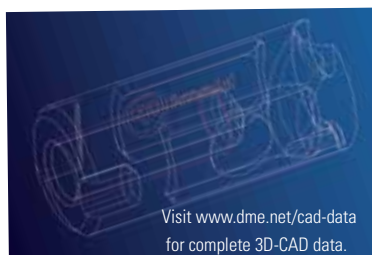
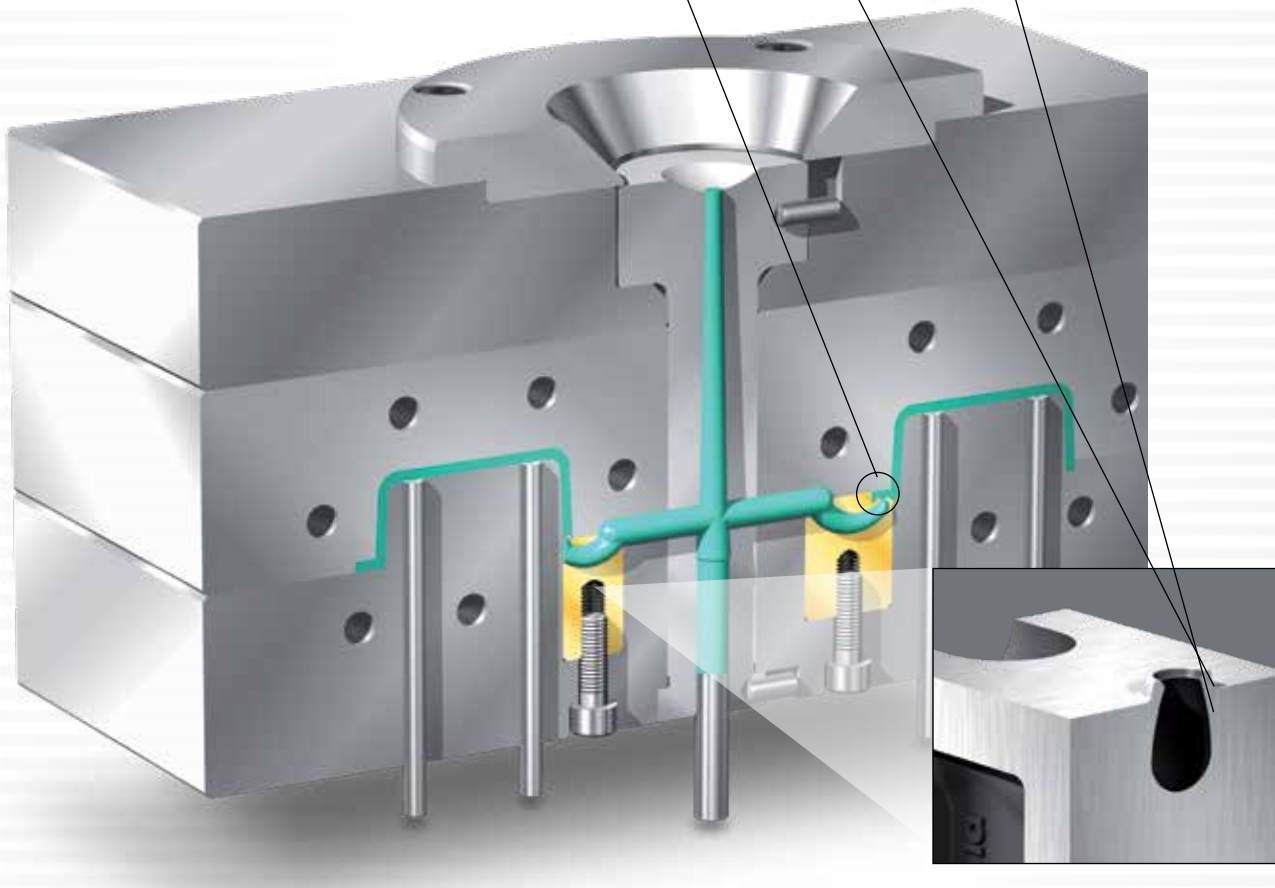

Visit www.dme.net/cad-data
for complete 3D-CAD data.



Auto De-gating System saving operating cost and boosting output of high-quality parts

The Opportunity

How do you handle de-gating parts today, for non-direct drop hot runners?

- Do you rely upon a robot with pneumatic side cutters or do you have special machines that degate for you?
- Do you incur the cost of an operator standing in front of a molding machine clipping gates and runners off each part?

By designing with DME Cashew Gates these costly secondary operations are no longer required. Cashew gates have a proven track record of producing high quality parts with little to no maintenance.

High Performance

Utilizing a unique MiM process we are able to mold the gates in a high performance M2 material. This process results in a steel hardness capable of withstanding the processing temperatures required for Engineered resins. We offer a wide range of styles for gating on the back side, ribs, sides, and multiple gating options to break below the surface of the part to avoid interference when a mating part is required.

Service

We offer free consultation in choosing the correct DME Cashew Gate for your application.

All we need is:

- A copy of your expanded model in XT or Step format
- Resin type
- Gate location
- The amount of cavities

We will send you back your model with the cashew gate installed within 24 hours.

Please send your information to DME_Mech_Eng@milacron.com

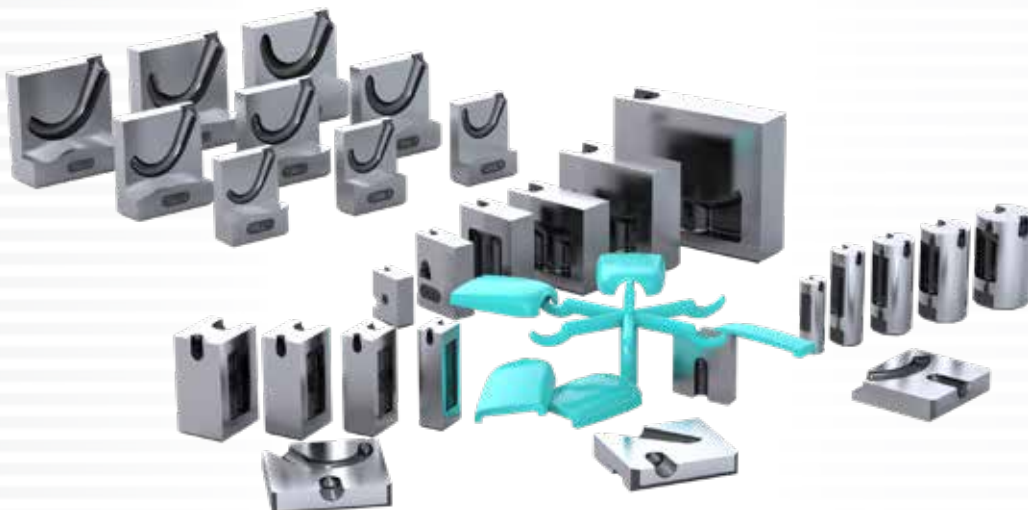

TECHNICAL INFORMATION

Viscosity Graph

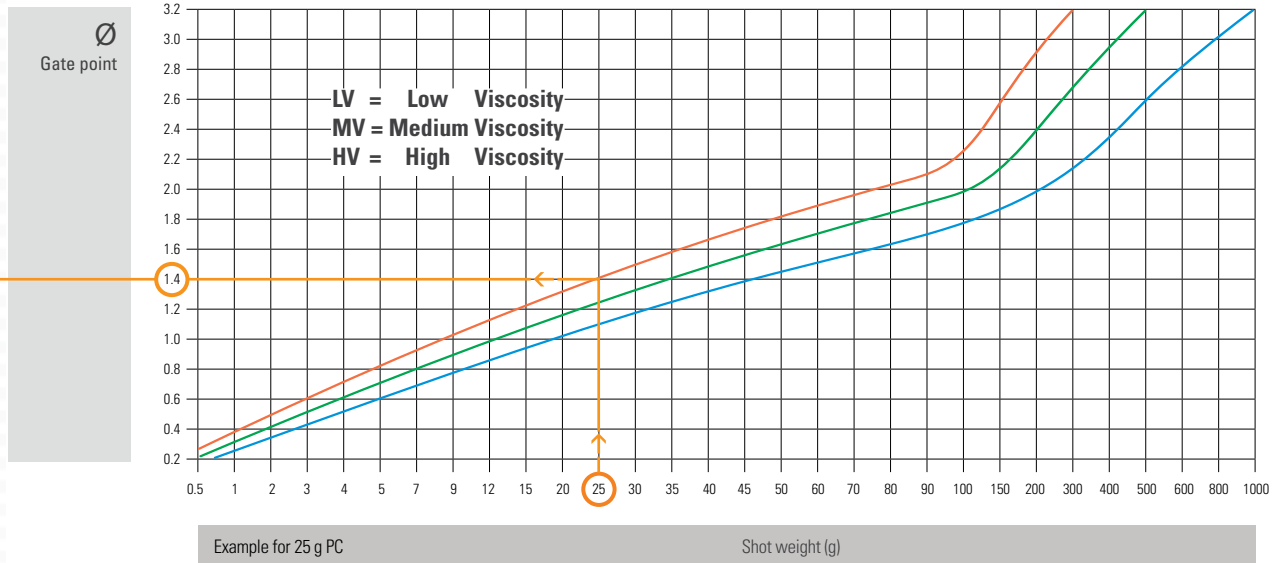

Caution: When using filled plastics (glass fibers, carbon fibers etc.) you should increase the computed gate diameter by 20%.

The recommended shot weights and gate diameters are guide values only! Please also take into account such individual parameters as part geometry, mold design, type of plastic and fillers.

Gate Diameter		Gate Diameter						
Ø	Cross-Sectional Area mm ²							
0.4	0.13	0.6	0.4	0.4	0.6	0.8		
0.6	0.28	0.8	0.6	0.6	0.8	1.0		
0.8	0.50	1.2	0.8	0.8	1.0	1.2		
1.0	0.78	1.6		1.0	1.2	1.4		
1.2	1.13	2.0		1.2	1.4	1.6		
1.4	1.54	2.4		1.4	1.6	1.8		
1.6	2.01	2.8		1.6	1.8	2.1		
1.8	2.54			1.8		2.8		
2.0	3.14						0.5 x (4.5)	
2.2	3.8						0.6 x (4.6)	
2.4	4.52						0.7 x (4.7)	
2.6	5.31						0.8 x (4.8)	
2.8	6.15						0.9 x (4.9)	
3.0	7.07						1.0 x (5.0)	
3.2	8.04						1.1 x (5.1)	
:	:						1.2 x (5.2)	
4.5	18.8						1.3 x (5.3)	
							1.4 x (5.4)	
							1.5 x (5.5)	
							4.5	

TGR / TGS / TGC / TGLL / TGML / TGHL
SGC
TPS



S2 with machining allowance TGR/TGS

Suitable for all plastics

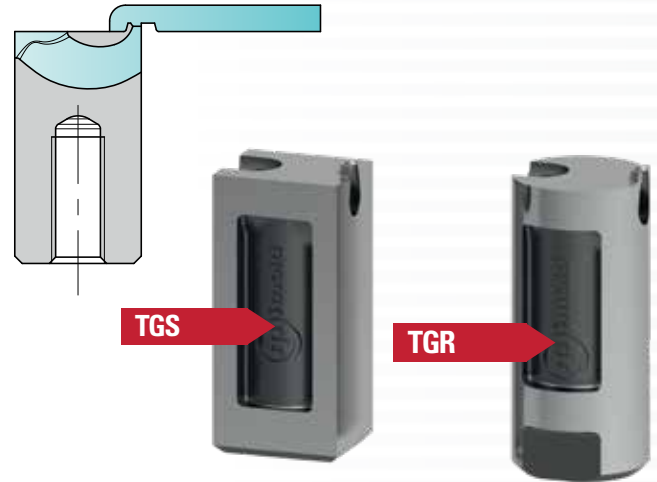

- For flat parting surfaces, including vestige with integrated cutting edge
- Ready to use! No adjustments necessary
- Highly wear-resistant hot working steel M2 (1.3343) – 60 HRC
- Available in round (TGR) and square (TGS) versions

	TGR 6	TGR/TGS 8	TGR/TGS 10	TGR/TGS 12	TGR/TGS 14
Gate Point	0.6	0.6 / 0.8	0.8 / 1.2 / 1.6	1.2 / 1.6 / 2.0	1.6 / 2.0 / 2.4 / 2.8
Ø Runner	2.5	3	4	5	6
Max. Shot Weight (g)					
LV	3	5	30	50	200
MV	2	4	20	35	120
HV	1	3	12	25	75

LV= Low Viscosity
MV= Medium Viscosity
HV= High Viscosity

Thermoplastic elastomers (TPE)

- Low Shore hardness = shorter distance L
- Use centering pin
- Max. hardness 100 Shore A

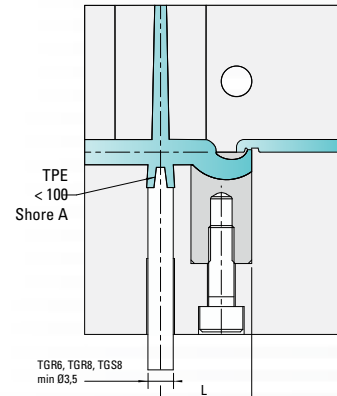
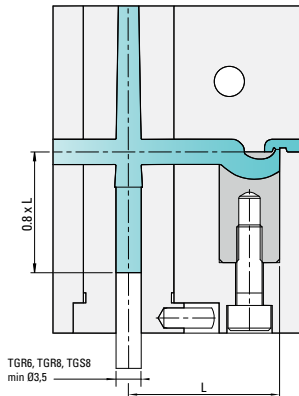
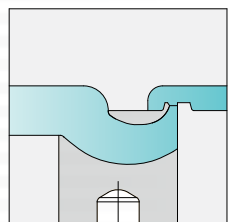

Table for Distance L

	Material type			
	TPE, TPU etc.	PE, PP, PET etc.	PC/ABS, PA, POM, HI-PC etc.	PA+GF, PC, SAN, PMMA, etc.
TGR 6	9-12	12-18	15-22	18-25
TGR/TGS 8	11-14	15-22	19-27	23-30
TGR/TGS 10	15-18	19-27	24-33	28-36
TGR/TGS 12	18-22	22-30	27-36	32-40
TGR/TGS 14	20-25	25-33	30-37	35-43

Recommendations



Companion vestige

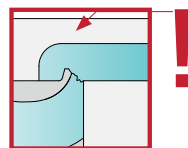

For optimum degating (especially of flat parts), we recommend the use of a companion vestige supplementing the vestige with cutting edge. This configuration will ensure that the part is separated from the runner flush with the parting line. Users will find this particularly advantageous in cases where materials are susceptible to stringing.

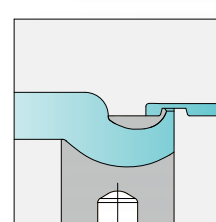

Flat Parts

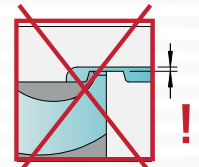

If the molded part is very thin, the calotte must be ground down. ($t_1 > t_2$)



S2 with machining allowance TGR/TGS

Suitable for all plastics

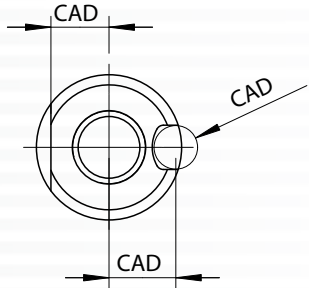

Anti-rotation locking possibility

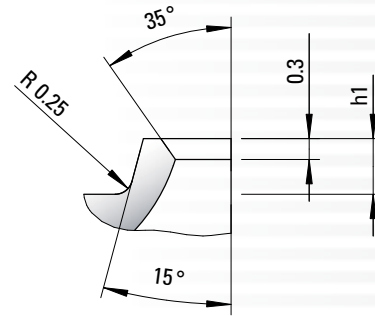
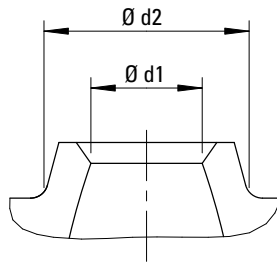
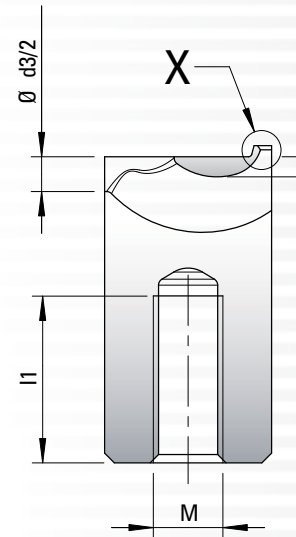
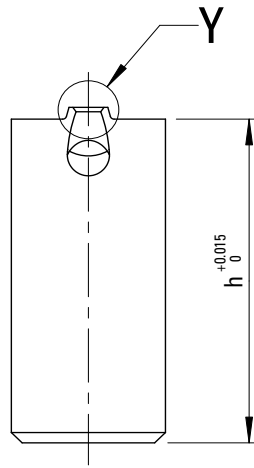

TGS	TYP	b	b1	d1	d2	d3	h	h1	h2	l1	l2	M	Version
	TGS8	8	6	0.6	1.9	3	22.0	0.6	1.1	13	3.25	4	S2
				0.8	2.1								
	TGS10	10	8	0.8	2.2	4	22.0	0.8	1.2	12	4	5	S2
				1.2	2.6								
TGS12	12	10	1.2	2.6	5	22.0	0.8	1.40	11	5	5	S2	
			1.6	3.0									
			2.0	3.4									
TGS14	14	12	1.6	3.0	6	22.0	0.8	1.6	10	6	6	S2	
			2.0	3.4									
			2.4	3.8									
			2.8	4.2									

TGR	TYP	d	d1	d2	d3	h	h1	h2	l1	l2	M	Version	
	TGR6	6	0.6	1.9	2.5	17.0	0.6	0.8	10	2.5	4	S2	
	TGR8	8	0.6	1.9	3	22.0	0.6	1.1	13	3.25	4	S2	
				0.8	2.1								
	TGR10	10	0.8	2.2	4	22.0	0.8	1.2	12	4	5	S2	
			1.2	2.6									
			1.6	3.0									
TGR12	12	1.2	2.6	5	22.0	0.8	1.40	11	5	5	S2		
			1.6	3.0									
			2.0	3.4									
TGR14	14	1.6	3.0	6	22.0	0.8	1.6	10	6	6	S2		
			2.0	3.4									
			2.4	3.8									
			2.8	4.2									

➔ Example of ordering designation : TGR6 -06- S2

EXAMPLES OF INSTALLATION

Under Wall

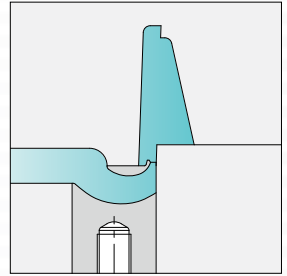
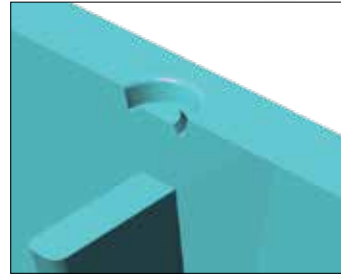
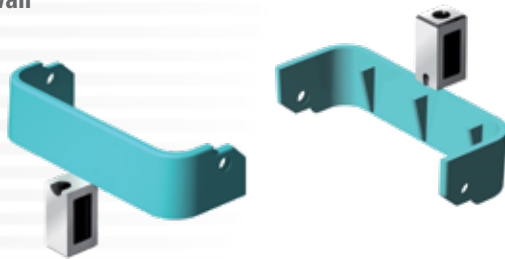

With Flow Promoter

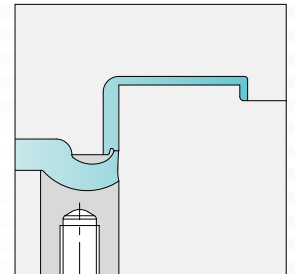
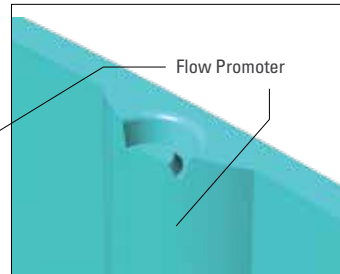
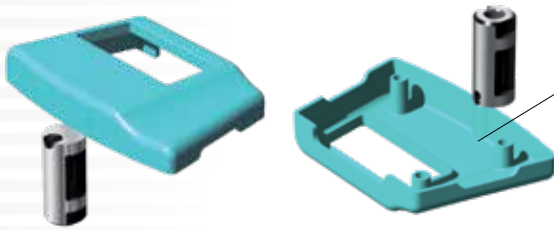

Adapted to Part

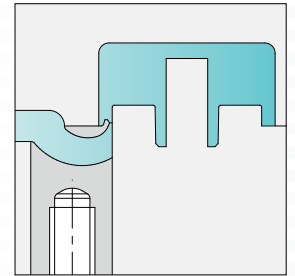
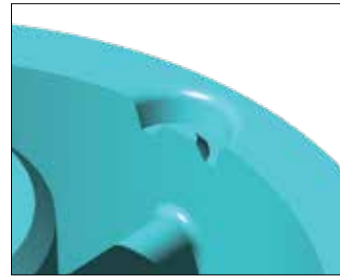
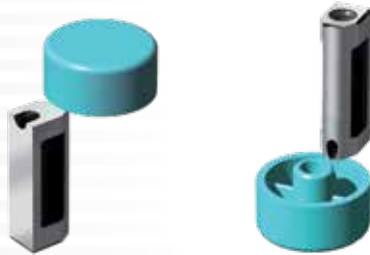

Flat Part with Companion Vestige – installation in fixed half of the mold

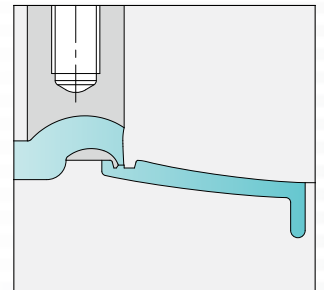

Flat Part without Companion Vestige

If a 100% clean separation of the sprue is not necessary or if reinforced plastics are being processed, the use of a companion vestige may be waived when molding flat parts. (see page 9).





S1 with machining allowance TGR/TGS

Suitable for all plastics

- With machining allowance on upper surface
- Slight contourings possible
- Same properties as version S2
- Highly wear-resistant hot working steel M2 (1.3343) – 60 HRC
- Available in round (TGR) and square (TGS) versions

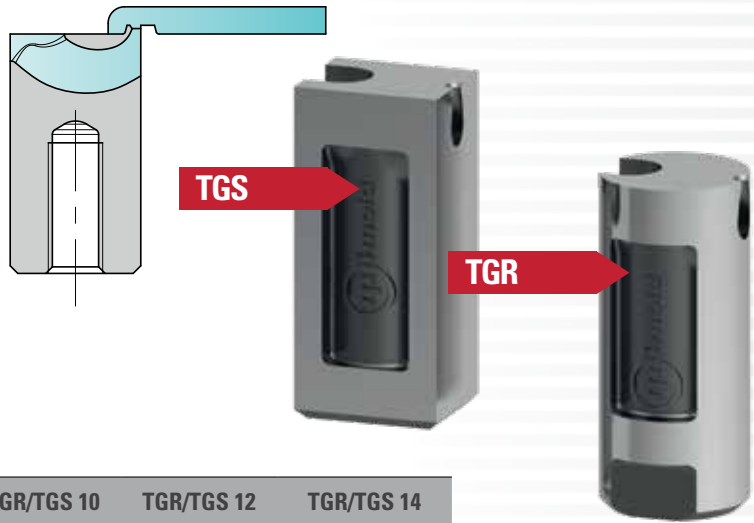

	TGR 6	TGR/TGS 8	TGR/TGS 10	TGR/TGS 12	TGR/TGS 14
Gate Point	0.6	0.6 / 0.8	0.8 / 1.2 / 1.6	1.2 / 1.6 / 2.0	1.6 / 2.0 / 2.4 / 2.8
Ø Runner	2.5	3	4	5	6
Max. Shot Weight (g)					
LV	3	5	30	50	200
MV	2	4	20	35	120
HV	1	3	12	25	75

LV = Low Viscosity
MV = Medium Viscosity
HV = High Viscosity

Thermoplastic elastomers (TPE)

- Low Shore hardness = shorter distance L
- Use centering pin
- Max. hardness 100 Shore A

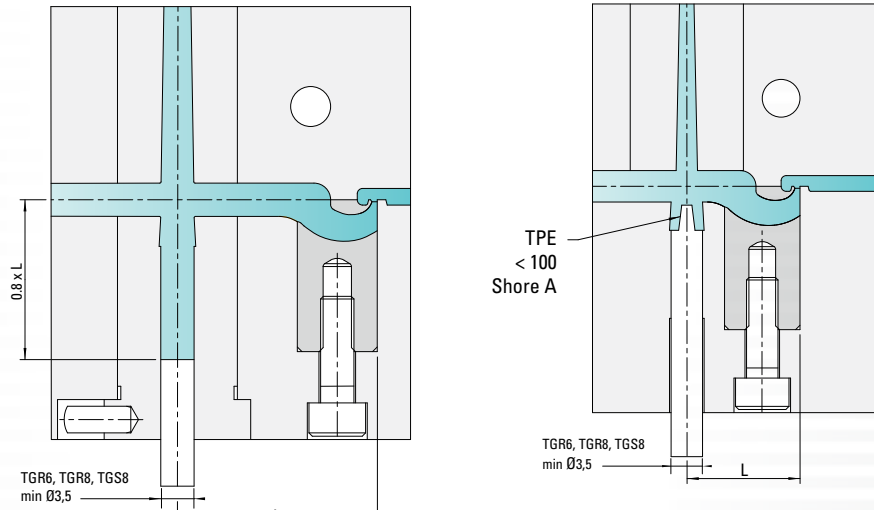
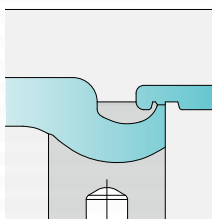

Table for Distance L

	Material Type			
	TPE, TPU etc.	PE, PP, PET etc.	PC/ABS, PA, POM, HI-PC etc.	PA+GF, PC, SAN, PMMA etc.
TGR 6	9-12	12-18	15-22	18-25
TGR/TGS 8	11-14	15-22	19-27	23-30
TGR/TGS 10	15-18	19-27	24-33	28-36
TGR/TGS 12	18-22	22-30	27-36	32-40
TGR/TGS 14	20-25	25-33	30-37	35-43

Recommendations



Companion vestige

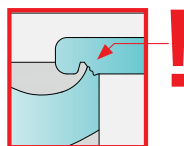

For optimum degating (especially of flat parts), we recommend the use of a companion vestige supplementing the vestige with cutting edge. This configuration will ensure that the part is separated from the runner flush with the parting line. Users will find this particularly advantageous in cases where materials are susceptible to stringing.

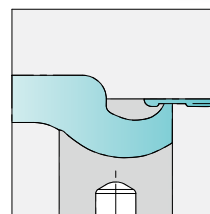

Flat Parts

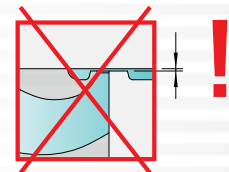

If the molded part is very thin, the calotte must be ground down. ($t_1 > t/2$)

S1 with machining allowance TGR/TGS

Suitable for all plastics

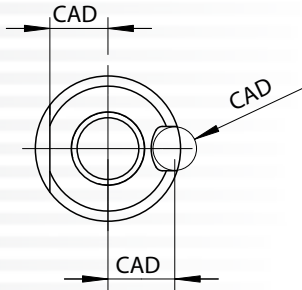

Anti-rotation locking possibility

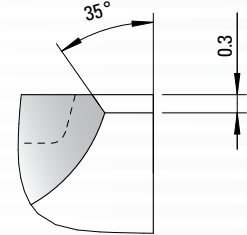
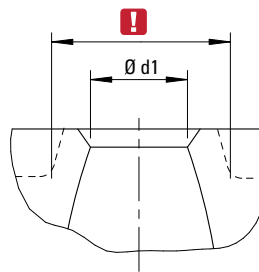
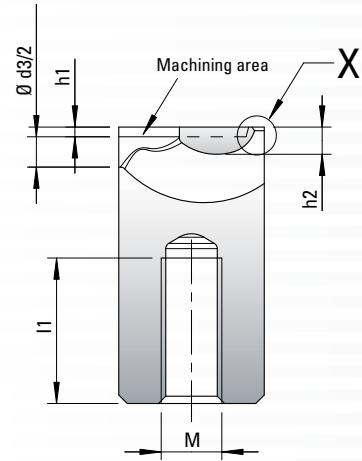
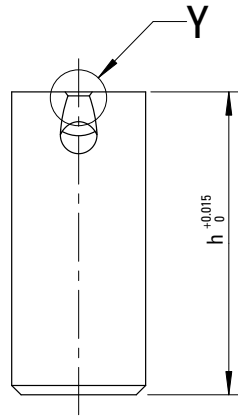

! Minimum size of vestige same as version S2

TGS	TYP	b	b1	d1	d2	d3	h	h1	h2	l1	l2	M	Version
	TGS8	8	6	0.6	1.9	3	22.0	0.6	1.1	13	3.25	4	S1
				0.8	2.1								
	TGS10	10	8	0.8	2.2	4	22.0	0.8	1.2	12	4	5	S1
				1.2	2.6								
				1.6	3.0								
	TGS12	12	10	1.2	2.6	5	22.0	0.8	1.40	11	5	5	S1
				1.6	3.0								
				2.0	3.4								
	TGS14	14	12	1.6	3.0	6	22.0	0.8	1.6	10	6	6	S1
				2.0	3.4								
				2.4	3.8								
				2.8	4.2								

TGR	TYP	d	d1	d2	d3	h	h1	h2	l1	l2	M	Version	
	TGR6	6	0.6	1.9	2.5	17.0	0.6	0.8	10	2.5	4	S1	
	TGR8	8	0.6	1.9	3	22.0	0.6	1.1	13	3.25	4	S1	
			0.8	2.1									
	TGR10	10	8	0.8	2.2	4	22.0	0.8	1.2	12	4	5	S1
				1.2	2.6								
				1.6	3.0								
	TGR12	12	10	1.2	2.6	5	22.0	0.8	1.40	11	5	5	S1
				1.6	3.0								
				2.0	3.4								
	TGR14	14	12	1.6	3.0	6	22.0	0.8	1.6	10	6	6	S1
				2.0	3.4								
				2.4	3.8								
2.8				4.2									

➔ Example of ordering designation : TGR6 -06- S1



EXAMPLES OF INSTALLATION

Rounded Edge

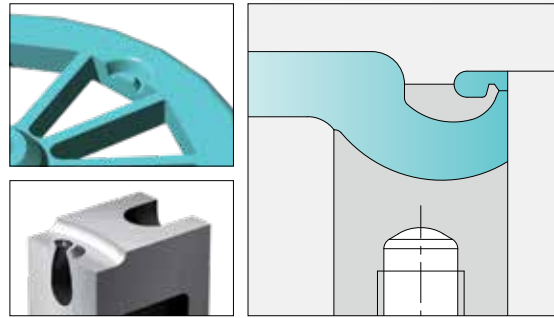

With Flow Promoter

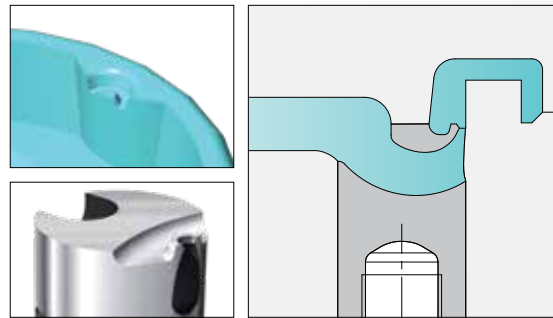
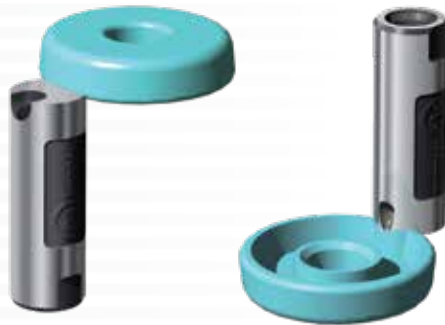

Rounded Separation

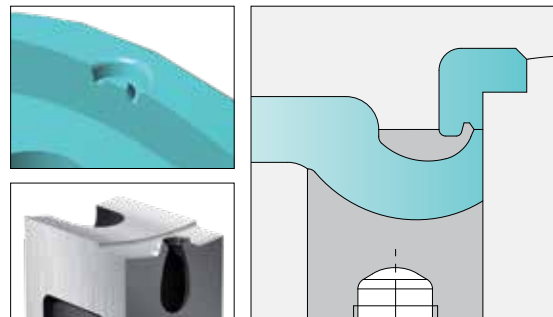

Flat with Companion Vestige

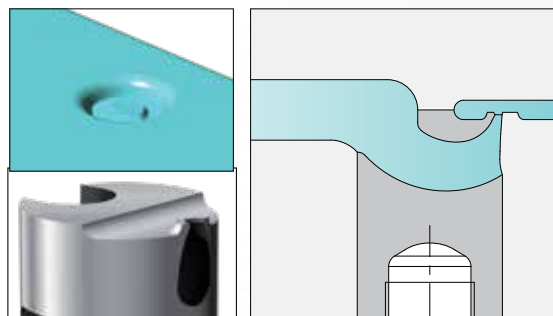

TGC^{contourable}

Perfect for rigid and enforced plastics

- For contouring up to 10mm
- Individually adjustable
- Highly wear-resistant hot working steel M2 (1.3343) – 60 / 40 HRC

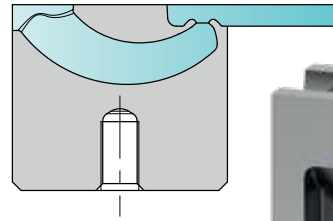

TGC



	TGC-XS	TGC-S	TGC-1	TGC-2	TGC-3	TGC-4
Max. Contour Depth	1	2	2	3	5	10
∅ Gate Point	0.4 - 0.6	0.4 - 0.8	0.6 - 1.2	0.8 - 1.8	0.5x4.5 - 1.5x5.5	0.5x4.5 - 1.5x5.5
∅ Runner	2.5	2.5	4	6	8	8
Max. Shot Weight (g)						
LV	5	12	35	120	1000	1000
MV	4	7	25	75	500	500
HV	3	5	15	50	300	300

LV = Low Viscosity
MV = Medium Viscosity
HV = High Viscosity

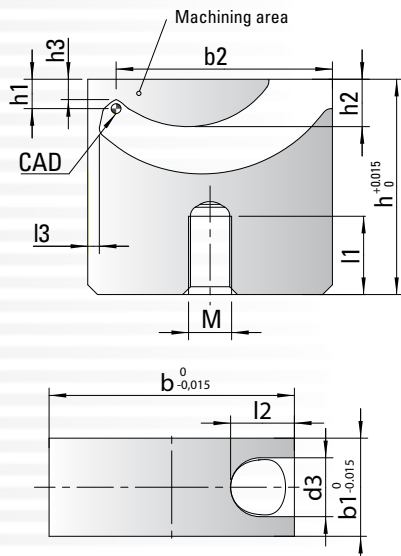

TGC-XS / TGC-S

Mounting possibilities

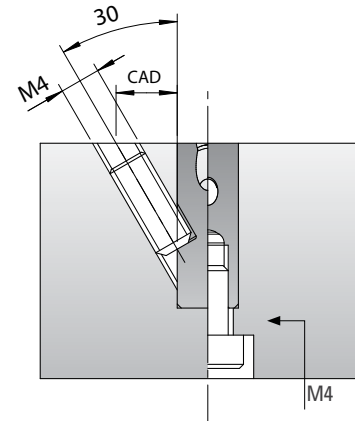

Typ	b	b1	b2	d3	h	h1	h2	h3	l1	l2	l3	M	HRC
TGC-XS	10	5	8.5	2.5	12	1	1.9	0.6	5	3.2	0.7	4	Version U = 40 HRC Version H = 60 HRC
TGC-S	15	6	13.3	2.5	18	2	3.5	1.5	8	4	0.9	4	
TGC-1	18	8	16	4	22	2	3.5	1.3	9	5.2	0.9	5	
TGC-2	25	10	22.1	6	22	3	4.8	2.1	8	6.5	1.2	5	
TGC-3	30	12	26.9	8	27	5	7.5	4.1	9	7	1.2	6	
TGC-4	45	12	41.2	8	36	10	16.7	9.1	8	9.6	1.8	6	

➔ Example of ordering designation : **TGC-XS-U**

TGC^{contourable}

Perfect for rigid and enforced plastics

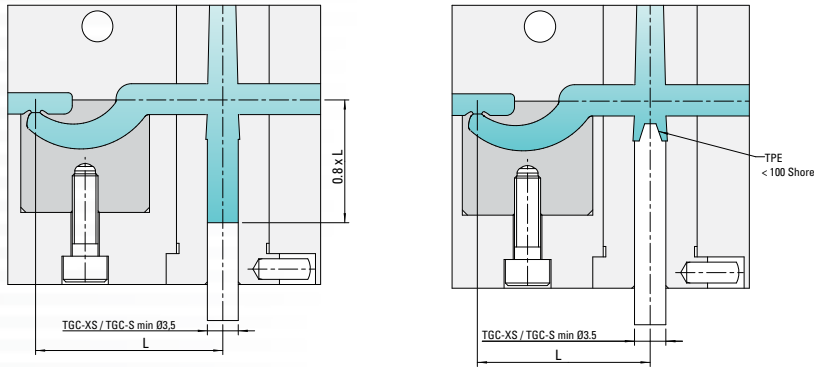

- Thermoplastic elastomers (TPE)**
- Low Shore hardness = shorter distance L
 - Use centring pin
 - Max. hardness 100 Shore A

Table for Distance L

	Material type			
	TPE, TPU etc.	PE, PP, PET etc.	PC/ABS, ABS, PA, POM, HI-PC etc.	PA+GF, PC, SAN, PMMA etc.
TGC-XS	12-16	13-20	16-23	22-29
TGC-S	16-21	18-25	21-28	27-34
TGC-1	21-26	26-34	31-39	36-45
TGC-2	28-33	31-39	36-44	41-50
TGC-3	33-38	38-48	43-53	48-58
TGC-4	48-53	53-63	58-68	X

➔ Vestige design > see additional tips (page 36)

X = Restrictedly suitable for rigid and reinforced plastics

EXAMPLES OF INSTALLATION

Under Surface

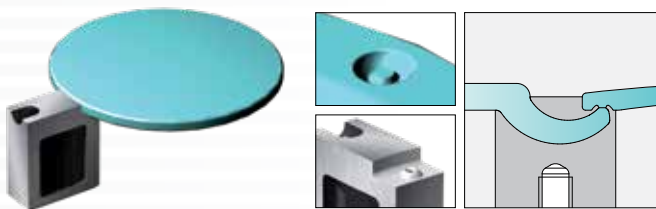

Under Rounded Surface



Half Gate Point

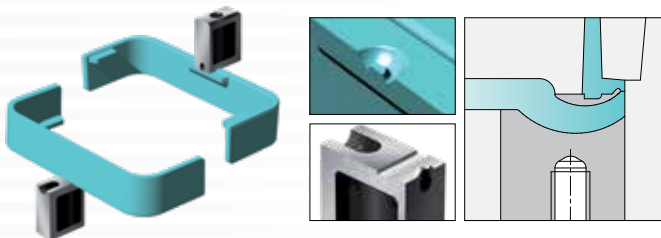

Angled Gating





TGLL contourable

Restrictedly suitable for rigid and enforced plastics

- Space-saving, contourable Tunnel Gate Insert for gating below the parting line
- Highly wear resistant hot working steel M2 (1.3343) 54+2 HRC

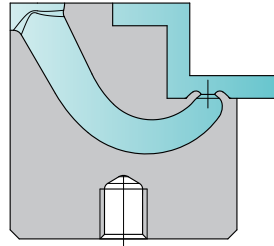

TGLL



	TGLL-1	TGLL-2	TGLL-3
Max. Contour Depth	8.5	10.5	12.5
∅ Gate Point	0.6 - 1.2	0.8 - 1.8	0.5x4.5 - 1.5x5.5
∅ Runner	4	6	8
Max. Shot Weight (g)			
LV	35	120	1000
MV	25	75	500
HV	15	50	300

LV = Low Viscosity
MV = Medium Viscosity
HV = High Viscosity

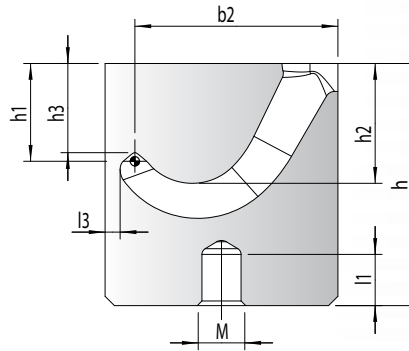
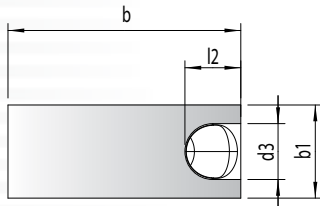

Typ	b	b1	b2	d3	h	h1	h2	h3	l1	l2	l3	M	HRC
TGLL-1	18	8	15.7	4	22	8.5	9.9	7.8	5.5	4.5	1.2	5	54+2
TGLL-2	25	10	21.8	6	26	10.5	12.9	9.6	5.5	6	1.6	5	
TGLL-3	30	12	26	8	30	12.5	14.8	11.6	6.5	7	2.2	6	

EXAMPLE OF INSTALLATION

TGLL Low Contour Step

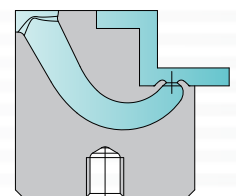
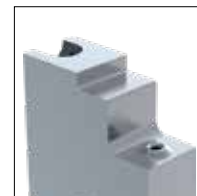



TGML contourable

Not suitable for rigid and enforced plastics

- Space-saving, contourable Tunnel Gate Insert for gating above the parting line
- Highly wear resistant hot working steel M2 (1.3343) 54+2 HRC

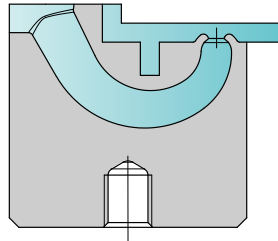

	TGML-1	TGML-2	TGML-3
Max. Contour Depth	5.5	6.5	7.5
Gate Point	0.6 - 1.2	0.8 - 1.8	0.5x4.5 - 1.5x5.5
Ø Runner	4	6	8
Max. Shot Weight (g)			
LV	35	120	1000
MV	25	75	500
HV	15	50	300

Vestige by 3D file

LV = Low Viscosity
 MV = Medium Viscosity
 HV = High Viscosity

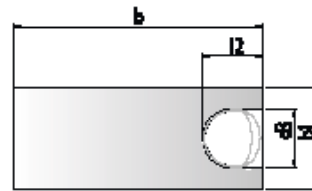
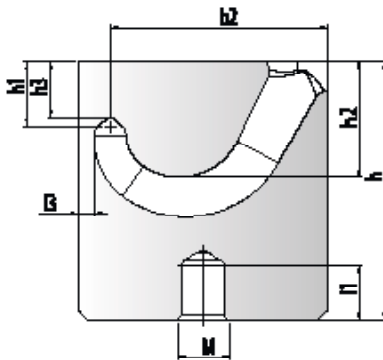

Typ	b	b1	b2	d3	h	h1	h2	h3	l1	l2	l3	M	HRC
TGML-1	18	8	15.7	4	22	5.5	9.5	4.86	5.5	4.5	1.2	5	54+2
TGML-1	25	10	21.8	6	26	6.5	11.6	5.6	5.5	6	1.6	5	
TGML-1	30	12	26	8	30	7.5	14.5	6.6	6.5	7	2.0	6	

EXAMPLE OF INSTALLATION

TGML with Peripheral Rib

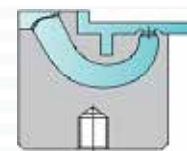
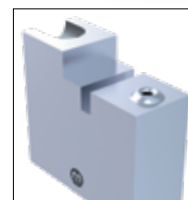



TGHL contourable

Not suitable for rigid and enforced plastics

- Space-saving, contourable Tunnel Gate insert for gating above the parting line
- Highly wear resistant hot working steel M2 (1.3343) 54+2 HRC



	TGHL-1	TGHL-2	TGHL-3
Max. Contour Depth	2	3	3
Gate Point	0.6 - 1.2	0.8 - 1.8	0.5x4.5 - 1.5x5.5
Ø Runner	4	6	8
Max. Shot Weight (g)			
LV	35	120	1000
MV	25	75	500
HV	15	50	300

Vestige by 3D file

LV = Low Viscosity
MV = Medium Viscosity
HV = High Viscosity

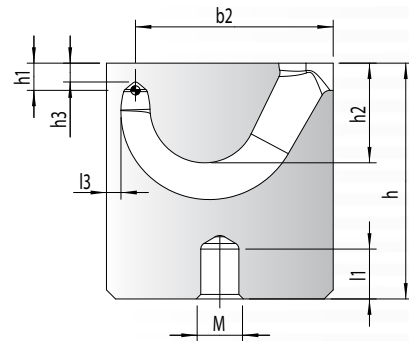
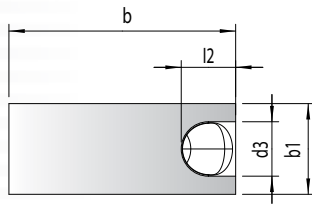

Typ	b	b1	b2	d3	h	h1	h2	h3	l1	l2	l3	M	HRC
TGHL-1	18	8	15.7	4	22	2	7.6	1.3	5.5	4.5	1.2	5	54+2
TGHL-2	25	10	21.8	6	26	3	11	2.1	5.5	6	1.6	5	
TGHL-3	30	12	26	8	30	3	12.2	2.1	6.5	7	2.0	6	

EXAMPLE OF INSTALLATION

TGHL High Contour Step



TGHL with Peripheral Rib

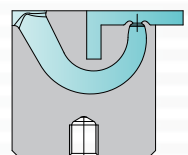
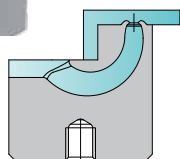

TGHL, TGML, TGLL contourable

Not suitable for rigid and enforced plastics

Example for 2 cavities

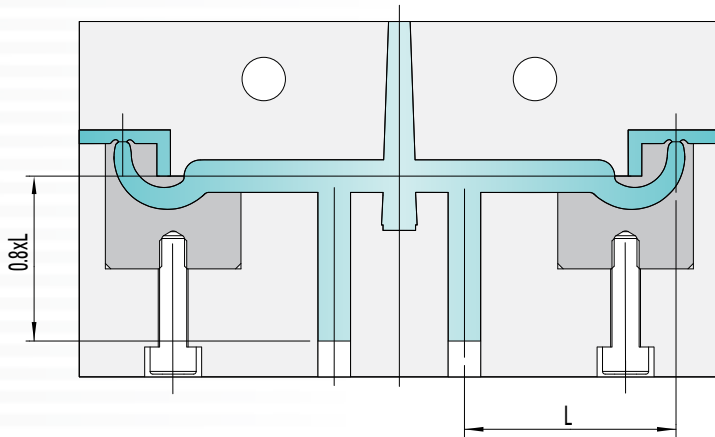

Example for 1 cavity

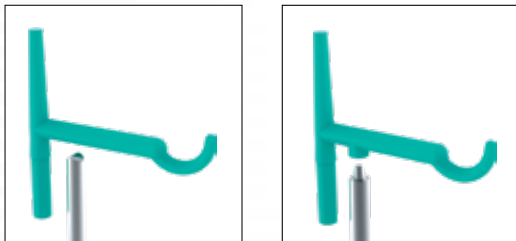
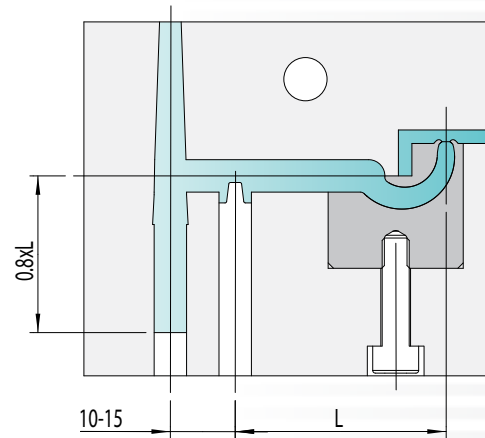

Example for supplementary ejector

Table for Distance L

	Material Type			
	TPE, TPU etc.	PE, PP, PET etc.	PC/ABS, PA, POM, HI-PC etc.	PA+GF, PC, SAN, PMMA etc.
TG-1(HL,ML,LL)	21-27	27-34	34-40	X
TG-2 (HL,ML,LL)	28-34	33-40	39-45	X
TG-3 (HL,ML,LL)	33-40	40-49	46-55	X

➔ Vestige design > see additional tips (page 27)

X = Not suitable for rigid and reinforced plastics



SGC^{side gating}

Suitable for all plastics

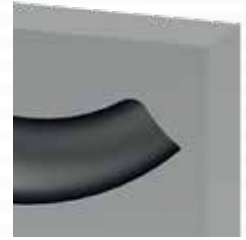
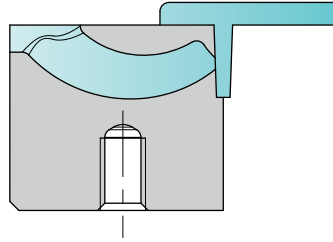

SGC

- Curved tunnel permits gating deep inside the part
- Integrated dead-end recess reduces loss of pressure and shear stress.
- Highly wear-resistant hot working steel M2 (1.3343) – 54+2 HRC

	SGC-XS	SGC-S	SGC-1	SGC-2	SGC-3
Gate Point	0.4 - 0.8	0.4 - 1.0	0.6 - 1.4	0.8 - 2.1	~ Ø 1.1 - 3.3
Ø Runner	2.5	2.5	4	6	8
Max. Shot Weight (g)					
LV	12	20	35	250	1000
MV	7	12	25	120	500
HV	5	8	15	90	300

LV = Low Viscosity
 MV = Medium Viscosity
 HV = High Viscosity

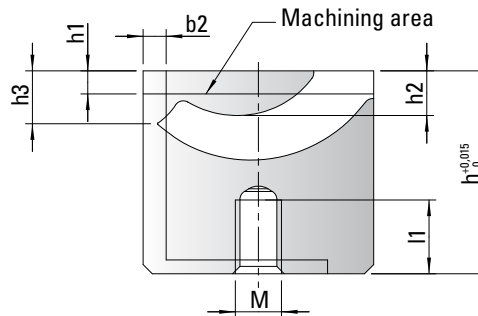
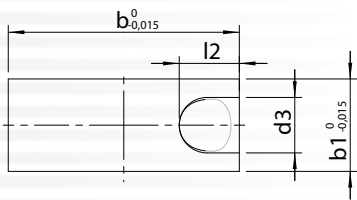

SGC-XS / SGC-S

Mounting Possibilities

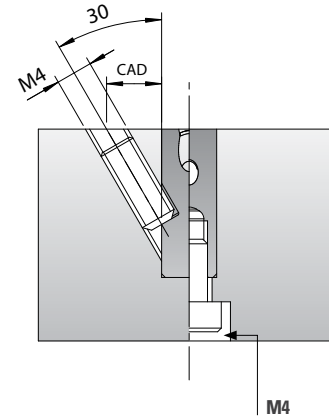

Typ	b	b1	b2 max.	d3	h	h1 max.	h2	h3	l1	l2	M
SGC-XS	10	5	1.1	2.5	12	0.6	1.9	2.0	5	3.2	4
SGC-S	15	6	2.0	2.5	18	2	3.5	4.0	8	4	4
SGC-1	18	8	1.8	4	22	2	3.5	4.1	9	5.2	5
SGC-2	25	10	2.5	6	22	2.5	4.8	5.7	8	6.5	5
SGC-3	30	12	2.8	8	27	4.5	7.5	8.4	9	7	6

➔ Example of ordering designation: **SGC-XS**

SGC^{side gating}

Suitable for all plastics

SGC-XS		
A [mm ²]	~ Ø [mm]	b2 [mm]
0.13	0.4	0.9
0.3	0.6	1.0
0.53	0.8	1.1

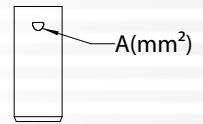
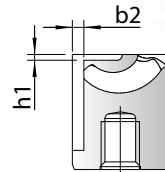

SGC-S		
A [mm ²]	~ Ø [mm]	b2 [mm]
0.15	0.4	1.7
0.33	0.6	1.8
0.55	0.8	1.9
0.79	1.0	2.0

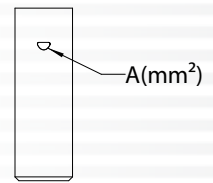
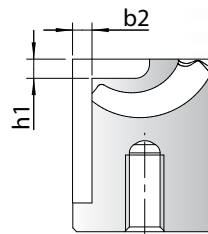

SGC-1		
A [mm ²]	~ Ø [mm]	b2 [mm]
0.28	0.6	1.4
0.53	0.8	1.5
0.82	1	1.6
1.15	1.2	1.7
1.52	1.4	1.8

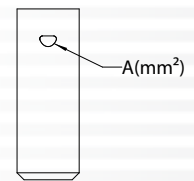
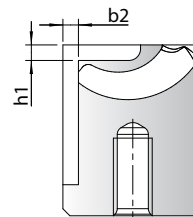

SGC-2		
A [mm ²]	~ Ø [mm]	b2 [mm]
0.28	0.6	1.7
0.54	0.8	1.8
0.84	1	1.9
1.2	1.2	2
1.57	1.4	2.1
2	1.6	2.2
2.43	1.75	2.3
2.9	1.9	2.4
3.4	2.	2.5

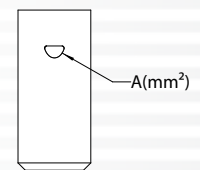
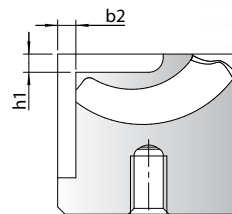

SGC-3		
A [mm ²]	~ Ø [mm]	b2 [mm]
1	1.1	2
1.75	1.5	2.1
2.56	1.8	2.2
3.43	2.1	2.3
4.35	2.35	2.4
5.32	2.6	2.5
6.33	2.85	2.6
7.38	3	2.7
8.48	3.3	2.8

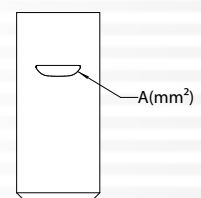
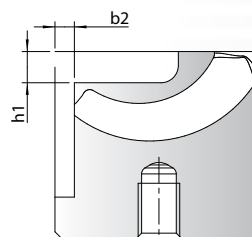

SGC^{side gating}

Suitable for all plastics

Standard installation for shallow and medium contour depths

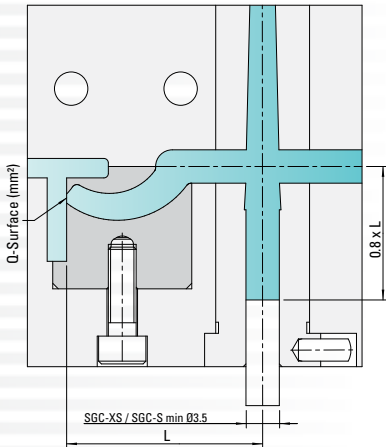

Special installation for deep contours

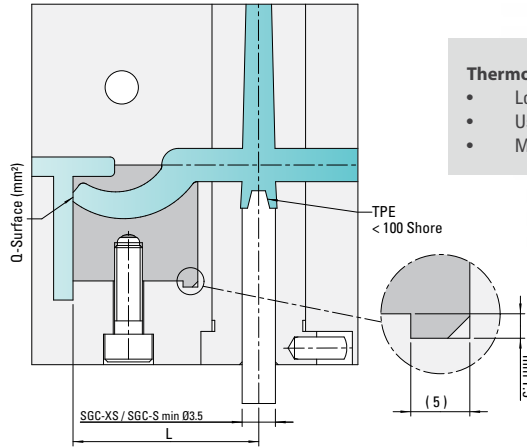

Thermoplastic elastomers (TPE)

- Low Shore hardness = shorter distance LL
- Use centering pin
- Max. hardness 100 Shore A

Table for Distance L

	Material Type			
	TPE, TPU etc.	PE, PP, PET etc.	PC/ABS, PA, POM, HI-PC etc.	PA+GF, PC, SAN, PMMA etc.
SGC-XS	12-16	13-20	16-23	22-29
SGC-S	16-21	18-25	21-28	27-34
SGC-1	21-26	26-34	31-39	36-45
SGC-2	28-33	31-39	36-44	41-50
SGC-3	33-38	38-48	43-53	48-58

Side Gating – Standard Installation

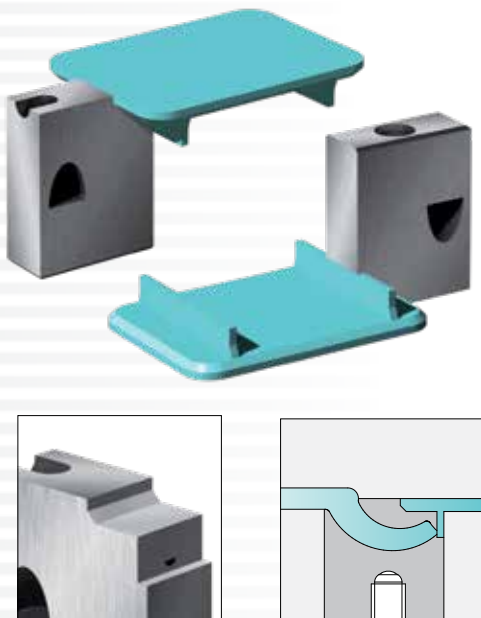

Side Gating – Adapted to Part

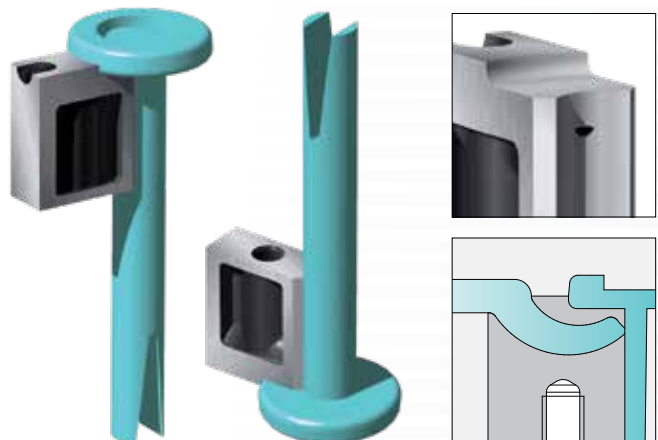



TPS^{tunnel gating}

Suitable for all plastics

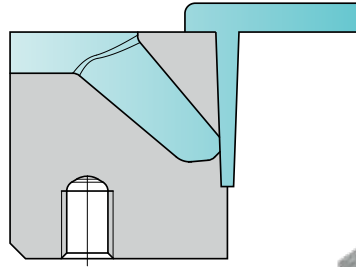

- Straight standard sub-gate for side-gating
- Integrated dead-end recess reduces loss of pressure and shear stress
- Highly wear-resistant hot working steel M2 (1.3343) – 54+2 HRC

	TPS-S	TPS-1	TPS-2	TPS-3
∅ Gate point	0.4 - 0.8	0.8 - 1.8	0.8 - 2.8	1.1 - 4.5
Max. Shot Weight (g)				
LV	30	120	600	1800
MV	20	75	350	1000
HV	12	50	175	600

LV = Low Viscosity
 MV = Medium Viscosity
 HV = High Viscosity

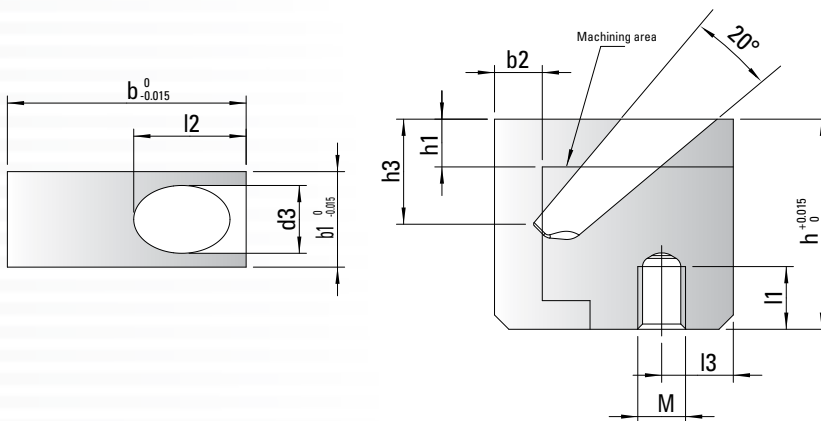

TPS

Mounting Possibilities

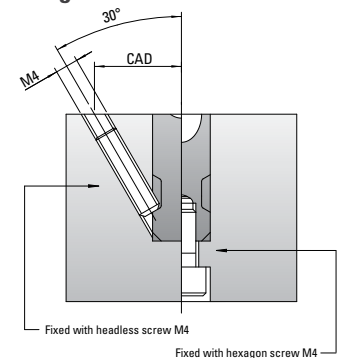

Typ	b	b1	b2 max.	d3	h	h1 max.	h3	l1	l2	l3	M
TPS-S	15	6	2.4	4	18	4	~7	6	7.1	5.5	4
TPS-1	18	8	2.6	6	22	5	~9	6	8.4	6	4
TPS-2	25	10	5	8	22	6	~11	6	11.8	7.5	5
TPS-3	30	12	6.5	10	27	7	~13	6	14.1	8	5

→ Example of order designation: TPS-1

TPS_{tunnel gating}

Suitable for all plastics

TPS-S

A [mm ²]	~ Ø [mm]	b2 [mm]
0.12	0.4	2.1
0.40	0.7	2.2
0.75	1.0	2.3
1.13	1.2	2.4

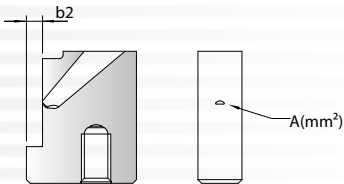

TPS-1

A [mm ²]	~ Ø [mm]	b2 [mm]
0.49	0.8	2.2
0.92	1.1	2.3
1.42	1.4	2.4
1.97	1.6	2.5
2.56	1.8	2.6

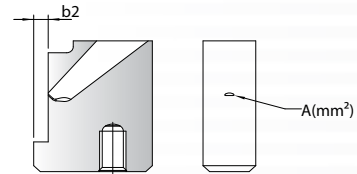

TPS-2

A [mm ²]	~ Ø [mm]	b2 [mm]
0.54	0.8	4.2
1.05	1.2	4.3
1.64	1.5	4.4
2.3	1.7	4.5
3.0	1.9	4.6
3.76	2.2	4.7
4.55	2.4	4.8
5.37	2.6	4.9
6.23	2.8	5.0

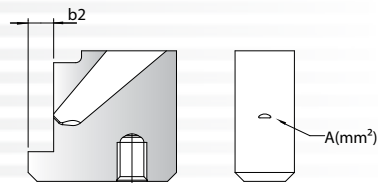

TPS-3

A [mm ²]	~ Ø [mm]	b2 [mm]
1.0	1.1	5.2
1.81	1.5	5.3
2.7	1.9	5.4
3.67	2.2	5.5
4.7	2.4	5.6
5.78	2.7	5.7
6.92	3.0	5.8
8.09	3.2	5.9
9.3	3.4	6.0
max. 15.8	4.5	6.5

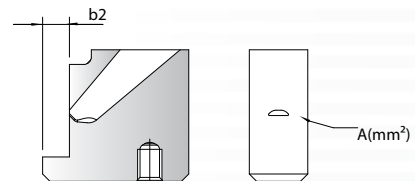

Thermoplastic Elastomers (TPE)

- Low Shore hardness = shorter distance L
- Use centring pin
- Max. hardness 100 Shore A

Standard installation for shallow and medium contour depths

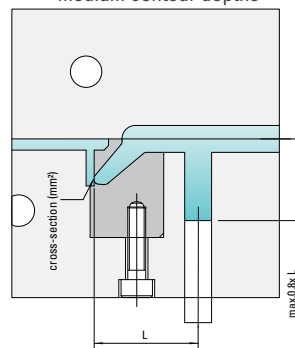

Special installation for deep contours

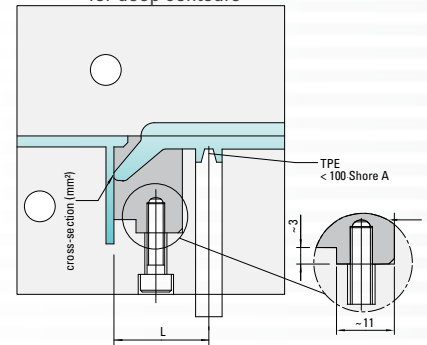
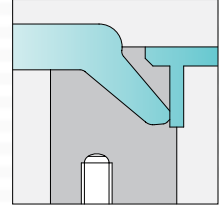
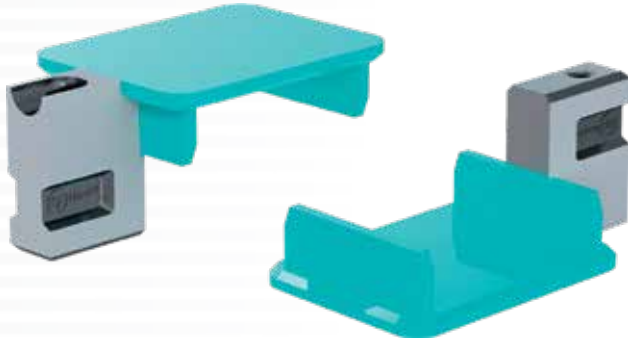

Table for Distance L

	Material Type	
	Flexible Materials	Rigid Materials
TPS-S	~ 18	~ 23
TPS-1	~ 22	~ 30
TPS-2	~ 28	~ 38
TPS-3	~ 33	~ 47

EXAMPLE OF INSTALLATION

Tunnel Gating – Standard Installation



Tunnel Gating – for Flat Contours

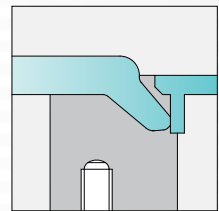
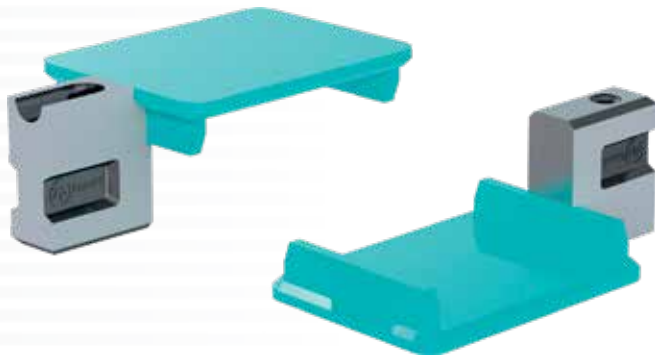

Tunnel Gating – for Deep Contours

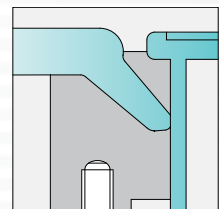



RB retaining bushing

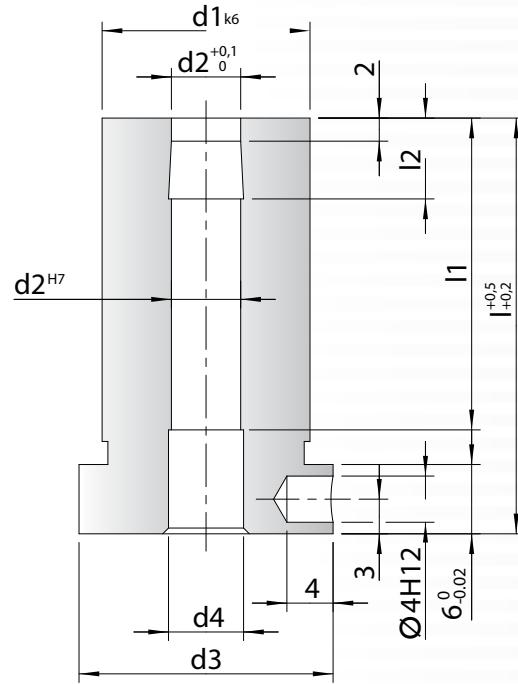

Available by special request. Please contact Customer Service.

l	l1	l2	d1	d2	d3	d4	Order No:
36	36						RB4-36
46	46	7	12	4	16	4.5	RB4-46
56	56						RB4-56
36	36						RB6-36
46	46	7	18	6	22	6.5	RB6-46
56	56						RB6-56
66	66						RB6-66
46	46						RB8-46
56	56	9.5	24	8	28	8.5	RB8-56
66	66						RB8-66

Material: 2826 ~58 HRC

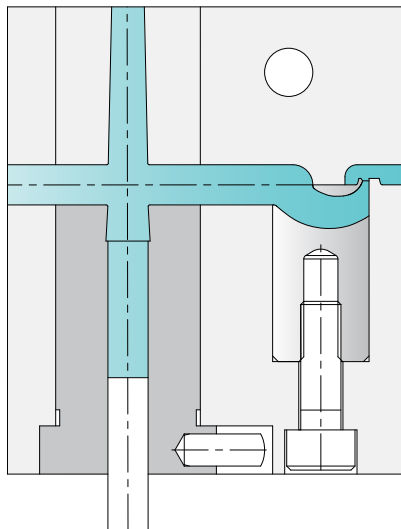

SUPPLEMENTARY TIPS

Dead-end recess

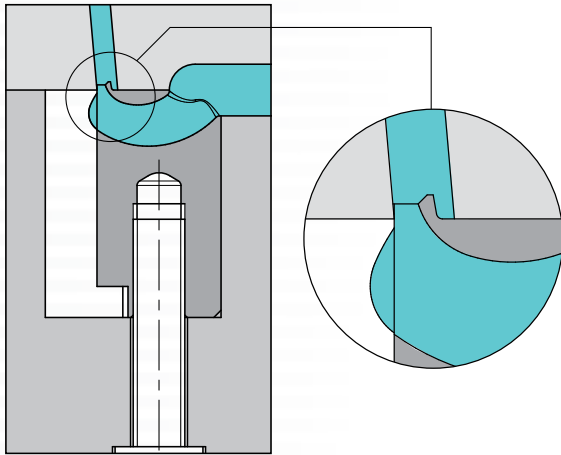

For the gating of housing parts we recommend incorporating a dead-end recess in an auxiliary insert or directly in the mold insert.

This feature optimizes the shear velocity in the gate area, gives a superior frontal flow, reduces the pressure loss and helps prevent jetting.

Spark-erosion machining of recesses

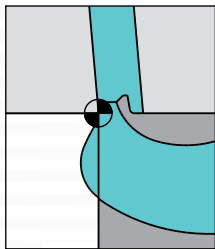

When machining the recess, take care to avoid undercutting the runner. For 3D data relating to standard insert sizes please refer to www.dme.net/cad-data (download section).

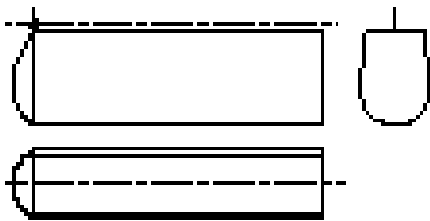

Auxiliary insert

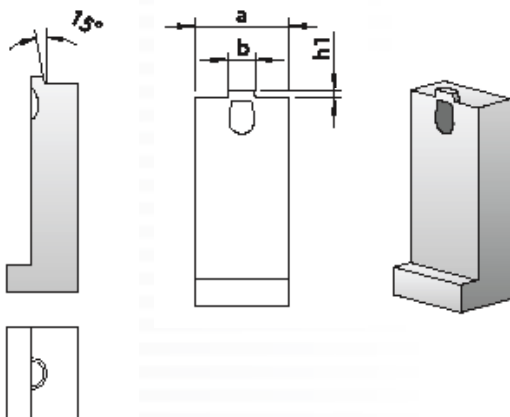

The companion vestige and/or dead-end recess can also be incorporated directly in the mold insert. The auxiliary insert should be made of a highly wear-resistant steel.

The dimensions a, b and h1 depend on the actual standard gate insert used.

SUPPLEMENTARY TIPS

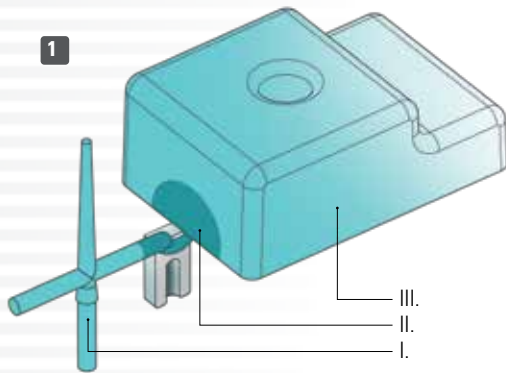

1

Graduated Injection Profile by Machine

1. High injection speed for filling the cold runner.
2. Low injection speed to ensure optimum frontal (laminar) flow.
3. High injection speed for quick mold filling, followed by holding pressure setting.

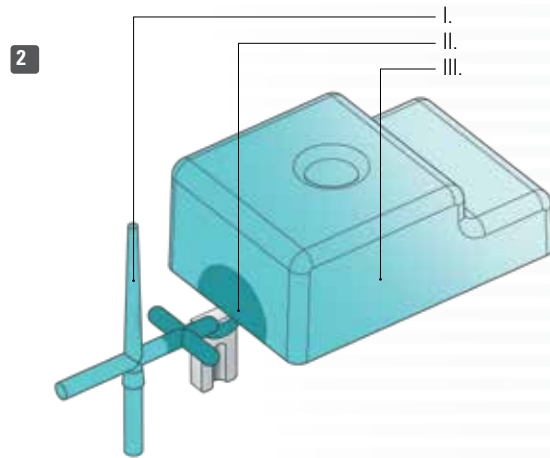

2

Mechanically Graduated Injection Profile

- Transverse runner reduces the velocity of the flow front in the gate area while machine parameters remain constant.
- For molds frequently used on different injection molding machines.

To avoid the risk of jetting and the formation of matt halo effects in the gate area, we recommend the use of a graduated injection profile.

Heat Sink Paste

PE, PP, POM, PC,
PBT, PEI, PPO, PS

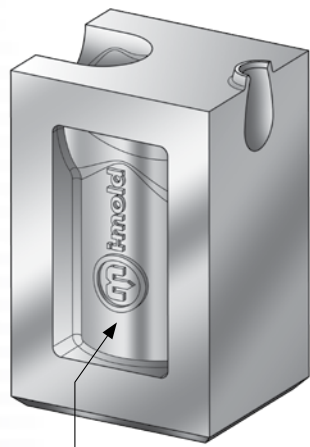

Heat sink paste

When processing temperature-sensitive materials or plastics susceptible to "stringing", we recommend the use of a heat sink paste in the lateral recesses.

- Prevents localized heating of the gate insert in molding processes with short cycle times.
- Improves heat dissipation so that the gate sealing point can be reached sooner.
- Enhances degating performance (no stringing, important when processing polyolefins).

It goes without saying that these gate inserts can also be used without heat sink paste. In certain applications the somewhat higher insert temperature permits a longer holding pressure phase.

SUPPLEMENTARY TIPS

Vestiges

TGC-XS / -S / -1 / -2 / TGLL-1 / -2 / GML-1 / -2 / TGHL-1 / -2

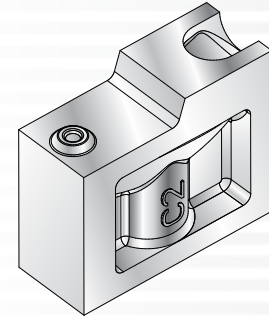

Standard Vestige

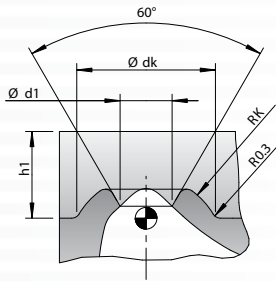

Small Vestige

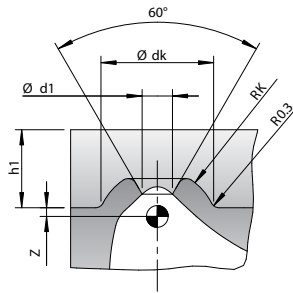

Maintain offset Z from CAD reference point!

	Vestige	h1	d1 max.	dk	Rk	Z
TGC-XS	Standard	1.0	0.6	2.5	1.6	-
TGC-S	Standard	2.0	0.8	2.7	1.7	-
TCG-1 / TGLL-1	Small	1.8	0.7	2.6	1.4	0.2
TGML-1 / TGHL-1	Standard	2.0	1.2	3.2	1.8	-
TCG-2 / TGLL-2	Small	2.75	1.2	3.5	2.0	0.25
TGML-2 / TGHL-2	Standard	3.0	1.8	4.5	2.6	-

Vestiges

TGC-3 / -4 / TGLL-3 / TGML-3 / TGHL-3

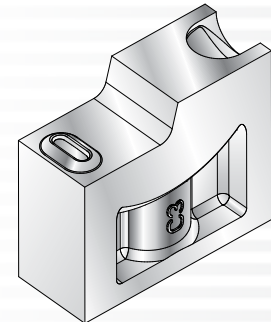

Standard Vestige

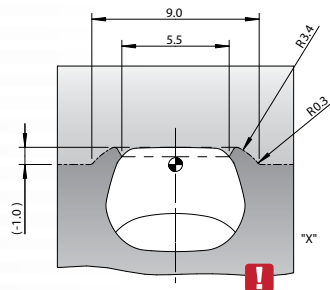
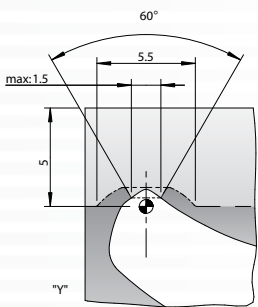

Small Vestige

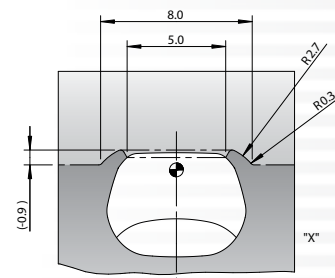
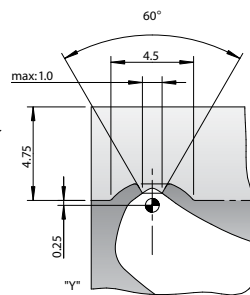

Vestige Versions

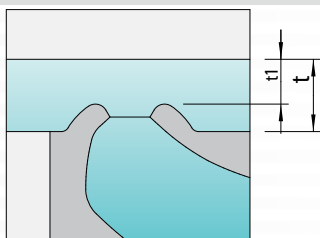

Spherical vestige with cone

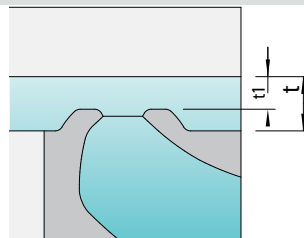

Flattened vestige with cone

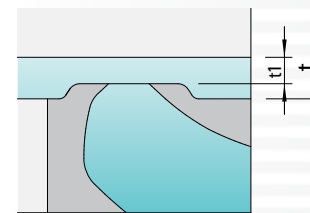

Flattened vestige without cone

$t1 > t/2$ t = wall thickness of plastic part

SUPPLEMENTARY TIPS

Spark-Erosion of Gate Area*

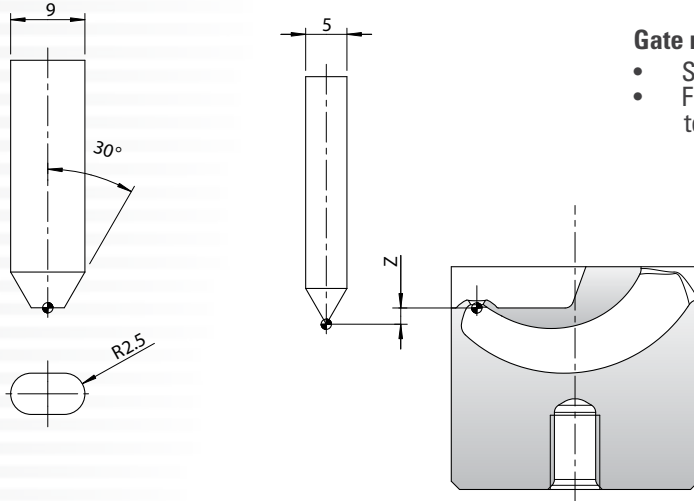

Gate machining by spark-erosion

- Simple positioning of electrode via coordinate system
- For 2D and 3D electrode geometry please refer to www.dme.net/cad-data (download section)

Milling of Gate Area*

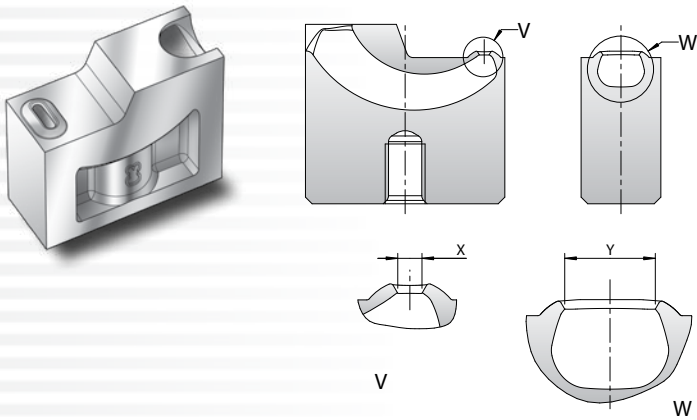

Gate machining by milling

- Easy milling of gate area via Y and Z-axis travel

*TGC 3+4 / TGLL-3 / TGML-3 / TGHL-3

Spark-Erosion of Gate Area		Milling of Gate Area	
Cross-sectional area [mm ²]	Electrode depth Z [mm]	Width X [mm]	Length Y [mm]
7.60	-0.86	1.5	5.5
7.00	-0.74	1.4	5.4
6.41	-0.62	1.3	5.3
5.84	-0.49	1.2	5.2
5.27	-0.37	1.1	5.1
4.72	-0.25	1.0	5.0
4.18	-0.13	0.9	4.9
3.65	-0.01	0.8	4.8
3.13	+0.11	0.7	4.7
2.63	+0.23	0.6	4.6
2.14	+0.35	0.5	4.5

INSTALLATION TCG/TGLL/TGML/TGHL

1 CAD reference point

Gate Point

2 Position the tunnel gate insert

3 Deduct the part's contour and vestige*

Vestige

* Contour surface of the vestige is contained in the 3D data

4 Adapt the feed channel*

Round off the transitions*

5 Machine the gate

Your One-Stop-Shop!

With tens of thousands of products to choose from, DME is your one-stop shop for everything molding. From complex undercuts solutions and plate control to standard pins, bushings and interlocks, the DME line of mold components will help you build or rebuild your mold base inside out, top to bottom. Industrial Supplies, Mold Bases, MUD Quick-Change, Control Systems, and Hot Runner solutions round out our extensive offering to truly be your one-stop shop.



World Headquarters
DME Company LLC
29111 Stephenson Highway
Madison Heights, MI 48071
800-626-6653 *toll-free tel*
248-398-6000 *tel*
888-808-4363 *toll-free fax*
www.dme.net *web*
dme@dme.net *e-mail*

DME of Canada Ltd.
6210 Northwest Drive
Mississauga, Ontario
Canada L4V 1J6
800-387-6600 *toll-free tel*
905-677-6370 *tel*
800-461-9965 *toll-free fax*
dme_canada@dme.net *e-mail*

DME Mexico / South America
Circuito el Marques Notre, No.55
Parque Industrial El Marqués
El Marqués, Querétaro, CP 76246
52.442.713.5666 *tel*
dme_mexico@milacron.com

