

# Cooling Products



## Section E Contents

<b>A</b>		
Adhesive Silicone .....	377	
Adjustable hex Nipples .....	413	
Air Couplers .....	384-385	
Aluminum Manifolds .....	365-368	
<b>B</b>		
Baffles .....	412	
Ball Valves .....	378	
Black Pipe Nipples-Fittings .....	424	
<b>Brass</b>		
Extension Elbows .....	407	
Gate Valves .....	378	
Pipe Adapters .....	416-417	
Pipe Extensions .....	398	
Pipe Nipples-Fittings .....	415	
Push-On Hose Barbs .....	419	
Bronze Y Strainer .....	431	
<b>C</b>		
Cable Ties .....	440	
Cam & Groove Couplings .....	429-431	
<b>Cascades</b>		
Assemblies .....	404	
Compact .....	406	
Extension Tubes .....	405	
Heads .....	405	
Hex Assemblies .....	406	
High Flow .....	403	
Nipple Type .....	405	
Tubes .....	404	
Clips-T .....	456	
<b>D</b>		
Delta-Q Flow Regulator .....	354-360	
Dr. Eddy Flowmeters .....	362-363	
Duct Tape .....	441	
Duoflow Manifolds .....	370	
<b>E</b>		
Electronic Flowmeters .....	347-348	
Ethylene Glycol .....	342	
<b>Extension</b>		
Elbows .....	407-408	
Pipes .....	409	
Plugs .....	399	
<b>F</b>		
Female Pipe Couplers .....	384	
Female Pipe Nipples .....	383	
Flange Adapters .....	432-435	
Flat Face Couplers .....	387	
<b>Flowmeters</b>		
Delta-Q Flow Regulator .....	354-360	
Dr. Eddy Flowmeter .....	362-363	
Electronic Flowmeters .....	347-348	
Flowmeters with Nylon end Caps .....	352	
Mechanical Flowmeters .....	352-353	
Nylon End Caps .....	352-353	
<b>Flow Regulators</b>		
Delta-Q Flow Regulators .....	354	
Multi-Zone Flow Regulators .....	344-345	
<b>Smartflow Flow Regulators .....</b>		364
<b>Forged Brass Ball Valves .....</b>		379
<b>G</b>		
<b>Galvanized Pipe Nipples .....</b>		424
<b>H</b>		
<b>Heat Transfer Fluid</b>		
Inhibited Ethylene Glycol .....		342
Therminol XP Heat Transfer Fuel .....		343
<b>Uninhibited Ethylene Glycol .....</b>		342
<b>Hex Cascade Assemblies .....</b>		406
<b>Hex Key Extension Elbows .....</b>		408
<b>Hex Key Extension Pipes .....</b>		409
<b>Hex Key Sets .....</b>		414
<b>Hi-Pressure Ball Valves .....</b>		380-381
<b>High Flow Cascade Tubes .....</b>		403-404
<b>High Flow Couplers .....</b>		382
<b>Hose</b>		
9000 Push-On .....		438
Barbs .....		418-419, 422
Clamps .....		452-454
Cutters .....		442
Dryer .....		448
General Purpose .....		438
High Performance .....		449
High Temperature .....		444
Insulated Duct .....		447
Loader .....		450
Metal Loader .....		451
Multi-Purpose .....		439
Pincers & Service Kits .....		455
PVC Air & Water .....		443
Recoil .....		446
Reels .....		443
Return Air Duct .....		449
Silicone Duct .....		447
T-Clips .....		456
Wrap .....		456
Hydraulic Adapters .....		416
Hydraulic Couplers .....		386
<b>I</b>		
Industrial Interchange Nipples .....		385
Inhibited Ethylene Glycol .....		342
<b>M</b>		
Male Pipe Couplers .....		382
Male Pipe Nipples .....		383
<b>Manifolds</b>		
Aluminum .....		365-368
Duoflow .....		370
Smartflow Aluminum .....		369-370
Steel .....		371-375
Metal Loader Hose .....		451
Mold Temperature Regulators .....		346
<b>N,P</b>		
Nipple Cascades .....		435
Pipe Extensions .....		405
Pipe Fittings .....		425-427
Pipe Nipples .....		415
Pipe Thread Check .....		397
Piston tubes .....		409
Platen Hose Clips .....		437
<b>Plugs</b>		
Extension Water Plugs .....		399
Pressure Plugs .....		414
Water Plugs .....		396
PTFE Tape .....		377
Push-In Tube Fittings .....		427-429
Push-Lok Hose Barbs .....		422
Push-To-Connect Water Couplers .....		392-394
<b>Q &amp; R</b>		
Quick Coupler Water Jumpers .....		401-402
<b>Quick Release Water Couplers</b>		
Flow-Through Water .....		388, 392
One-Way Shutoff .....		390
Two-Way Shutoff .....		391
Retaining Clips .....		395
<b>S</b>		
Silicone Adhesive .....		377
Silicone Washers .....		395
Smartflow Alum. Manifolds .....		369-370
Split Flange Adapters .....		432-435
Standard Hose barbs .....		418
Steel Hex Elbows .....		407
Steel Hydraulic Adapters .....		421
Steel Manifolds .....		371-375
Steel Pipe Adapters .....		420
Straight Blade Baffles .....		412
<b>T</b>		
T-Handle Ball Valves .....		378
Therminol XP Heat Transfer Fluid .....		343
Thread Inserts .....		423
Thread Repair Kits .....		423
Thread Sealant .....		377
Thread Sealing Tape .....		377
Tool Balancing System .....		446
Turbo Blade Baffles .....		412
<b>U, V</b>		
Uninhibited Ethylene Glycol .....		342
Vacuum Loader Hose .....		450
Viton Washers .....		395
<b>W, Y</b>		
Washers .....		395
Water Coupler Retainer Clips .....		395
<b>Water Couplers</b>		
Flow Through .....		388, 392
One-Way Shutoff .....		390, 393
Two-Way Shutoff .....		391, 394
Water Jumpers .....		401-402
<b>Water Manifolds</b>		
Aluminum .....		365-368
Duoflow .....		370
Smartflow Aluminum .....		369-370
Steel .....		371-375
Water Plugs .....		396
Wire & Hose Wrap .....		456
Y Strainer .....		431

E



# Ethylene Glycol

## Inhibited Ethylene Glycol

Ethylene Glycols are used in applications involving secondary cooling and heat transfer, providing freeze and burst protection. Plain water and “antifreeze” type products do not have the proper inhibitor package for these heavy industrial uses.

Compared with inhibited glycols, uninhibited glycols oxidize in the presence of air and heat, forming acids. These acids can be corrosive to the metal in a system. Inhibited glycols neutralize the acids formed and thus protect against corrosion.

### Applications:

Ethylene Glycol Inhibited is almost odorless, easily mixes with water, and is moderately toxic.

Ethylene Glycol Inhibited is effective from -60° to 250°F.

The proper concentration to use is a function of the lowest anticipated temperature. Try to provide protection about 5° lower than this. However, for best corrosion protection do not go below 30% by volume.

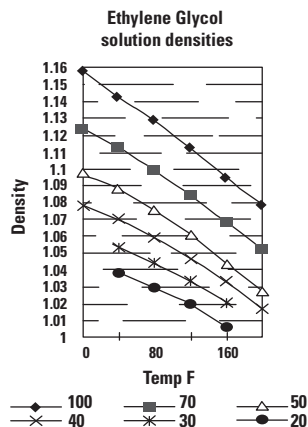

## INHIBITED

Inhibited Ethylene Glycol	
Part Number	Container Size
ELG2-5	5 Gal.
ELG2-55	55 Gal.
ELG2-55	55 Gal.
ELG2-55	55 Gal.

## UNINHIBITED

Uninhibited	
Part Number	Container Size
ELG5	5 Gal.
ELG55	55 Gal.

- Pure ethylene glycol circulator fluid, no additives
- For use from -40° to +250°F (Dilute)
- Good rust preventative properties
- Non-corrosive, will not build-up
- High flash point, +240°F
- Shipped from stock
- Compare our quality, compare our price!

Therminol XP heat transfer fluid is an extremely pure white mineral oil which provides reliable heat transfer 0° to 600°F. Performance features of Therminol XP include:

- Low fouling - The purity of Therminol XP minimizes fouling as a result of oxidation and degradation of the fluid, provided proper attention is given to system design and operation within the maximum bulk and film temperatures specified.
- Practically non-toxic: As an indicator of purity, Therminol XP meets FDA specifications defined in 21 CFR 172.878 and requirements of United States Pharmacopeia (USP) and National Formulary (NF).
- Thermal stability - Therminol XP is stable to 600°F. Users can expect many years of reliable, trouble-free operation, even when operating continuously at the recommended maximum temperature of 600°F.
- Environmentally friendly - Therminol XP has outstanding regulatory status for those seeking heat transfer fluids which have minimum environmental reporting requirements.
- Therminol XP is used in a wide variety of industries, such as:
  - Plastics processing
  - Pharmaceuticals
  - Specialty chemicals
  - Laundries



55 Gallon Drum



5 Gallon Pail

<b>Appearance</b>	Colorless, odorless liquid
<b>Composition</b>	White mineral oil, USP/NF
<b>Flash Point</b> (ASTM D-92)	182°C (360°F)
<b>Fire Point</b> (ASTM D-92)	196°C (385°F)
<b>Autoignition Temperature</b> (ASTM D-2155)	324°C (615°F)
<b>Kinematic Viscosity</b> , at 40°C	23.7 mm <sup>2</sup> /s (cSt)
at 100°C	4.06 mm <sup>2</sup> /s (cSt)
<b>Density at 25°C</b>	875 kg/m <sup>3</sup> (7.30 lb/gal)
<b>Specific Gravity</b> (60°F/60°F)	0.882
<b>Coefficient of Thermal Expansion</b> at 200°C	0.000892/°C (0.000495/°F)
<b>Average Molecular Weight</b>	350
<b>Pour Point</b>	-29°C (-20°F)
<b>Pumpability</b> , at 2000 mm <sup>2</sup> /s (cSt)	-20°C (-4°F)
<b>at 300 mm<sup>2</sup>/s (cSt)</b>	-1°C (30°F)
<b>Minimum Temperatures for</b>	
Fully Developed Turbulent Flow (Re = 10000)	
10 ft/sec, 1-in tube	72°C (162°F)
20 ft/sec, 1-in tube	51°C (123°F)
Transition Region Flow (Re = 2000)	
10 ft/sec, 1-in tube	30°C (85°F)
20 ft/sec, 1-in tube	17°C (63°F)
<b>Boiling Range</b> , 10%	332° C (630°F)
90%	416°C (780°F)
<b>Normal Boiling Point</b>	358°C (676°F)
<b>Heat of Vaporization at Maximum</b>	
Use Temperature 315°C	214 kJ/kg (91.9 Btu/lb)
<b>Optimum Use Range</b>	-20°C to 315°C (0°F to 600°F)
<b>Maximum Film Temperature</b>	330°C (625°F)
<b>Pseudocritical Temperature</b>	542°C (1007°F)
<b>Pseudocritical Pressure</b>	15.2 bar (220 psia)
<b>Pseudocritical Density</b>	280 kg/m <sup>3</sup> (17.5 lb/ft <sup>3</sup> )
<b>Vapor Pressure, psia @</b>	
200°F	0.0005
300°F	0.003
400°F	0.147
500°F	0.967

## Therminol XP™

## HEAT TRANSFER FLUID

Part Number	Container Size
HTFXP5	5 Gallon
HTFXP55	55 Gallon

Shipping weight: 5 gallon/41 Lbs, 55 gallon/465 Lbs



# Flow Regulator

Flow meters for monitoring and regulating flow through mold.

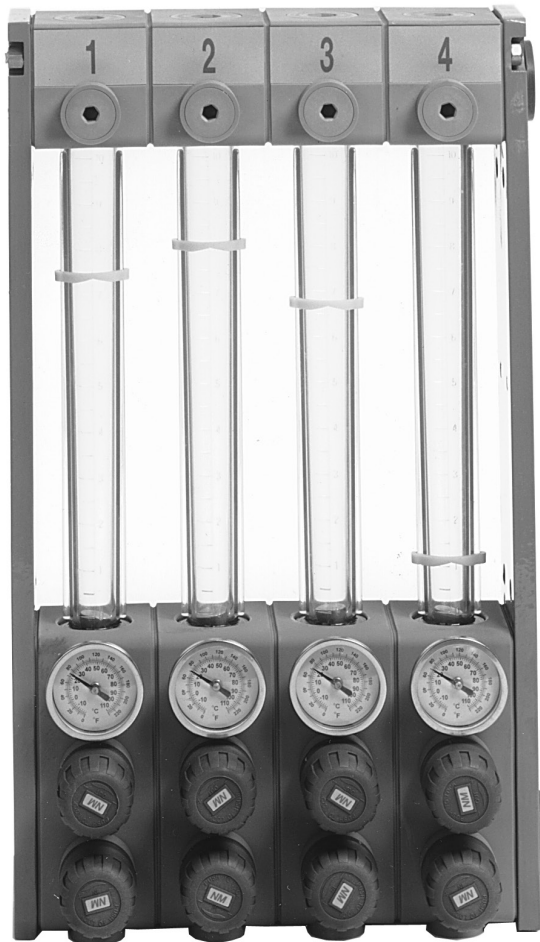

- Larger model 2.65 or 5.3 gpm flow rates
- Up to 210°F/100°C
- 180 PSI
- Manifold blocks made from tough glass-filled nylon construction. Aluminum side plates.
- May be used with ethylene glycol
- From glass-filled nylon
- Cleaning brush included
- Brass valves (push-lock)
- Temp gauge in each tube 0 to 220°F
- Flow rate: 0 to 2.65 G.P.M. (10 liter/min.)  
0 to 5.3 G.P.M. (20 liter/min.)

## FLOW REGULATOR

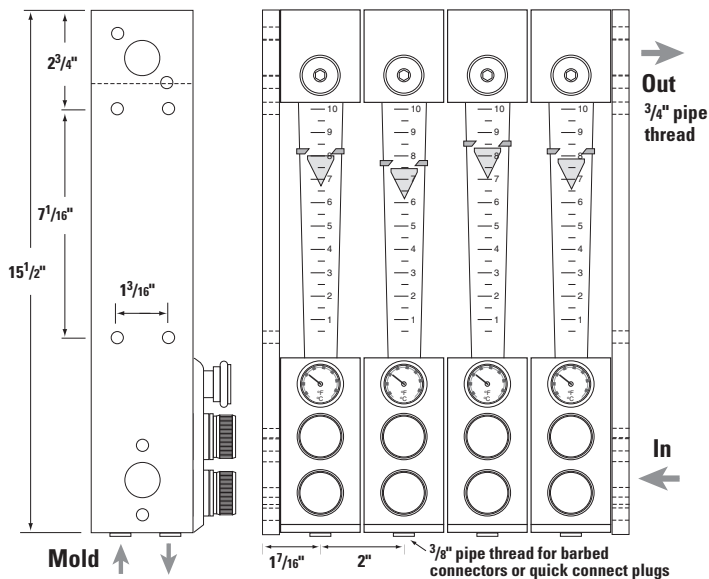
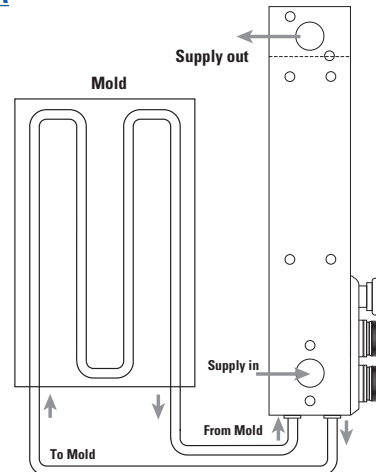

Easy cleaning capability without dismantling (access to tubethrough removable top plug.)



# Flow Regulator



Easy cleaning capability without dismantling (access to tube through removable top plug.)

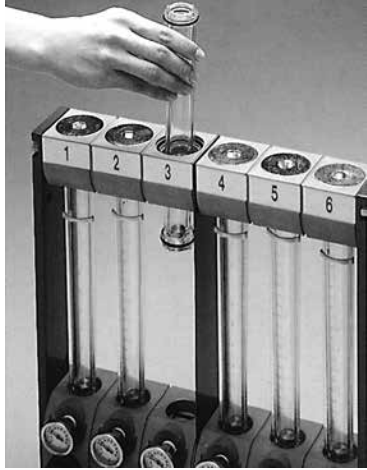

Part Number	Description
12001-2	Lower Housing
12010-4	Upper Housing
12003	Sight Glass
12004	Reference Ring
12020	Fixed Plug
12006	Plug 3/4" NPT
19012	Hand Wheel
99014	Control Valve
22001	O-Ring
22002	O-Ring
22003	O-Ring
22014	O-Ring
22005	O-Ring
29012	O-Ring
29016	O-Ring
30011	Thermometer
52001	R. Side Plate
52002	L. Side Plate
52200	Screw
52005	Nut
52003	Cone
12014	Plug
22010	O-Ring

## Flow Cones available

Max Gallons/Min.	Part Number
2.64 (10 L/min)	FC10M
5.3 (20 L/min)	FC20M

## Flow System Matic Water Flow Regulators

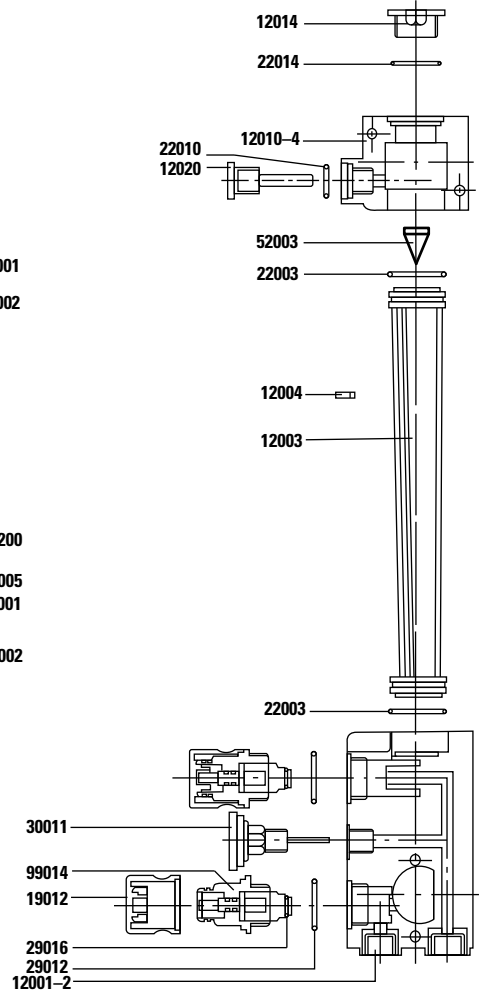
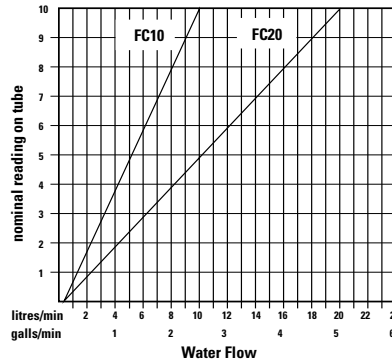
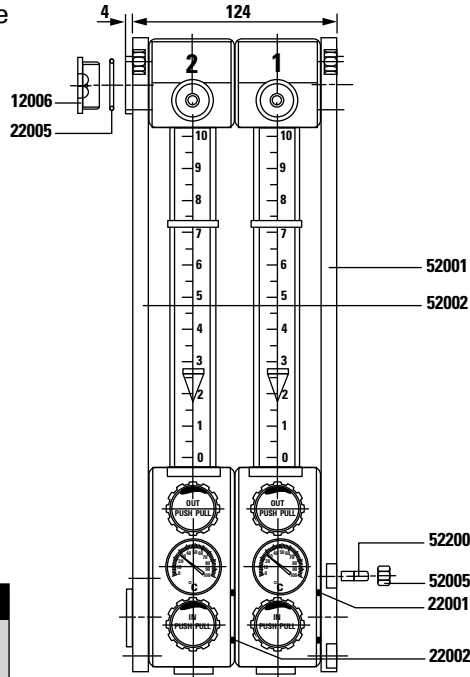

## Larger Model 2.65 or 5.3 GPM Flow Rates

Description	W (in)	Part Number
Two Zone Assembly	4.88"	FR2
Three Zone Assembly	6.93"	FR3
Four Zone Assembly	8.98"	FR4
Five Zone Assembly	11.06"	FR5
Six Zone Assembly	13.15"	FR6
Eight Zone Assembly	17.24"	FR8
Ten Zone Assembly	21.46"	FR10
Twelve Zone Assembly	25.55"	FR12

## Spare Flow Tubes

Max Gallons/Min.	Part Number
2.64 or 5.28 GPM	12003
Flow tube seals (10)	22003





# Mold Temperature Regulator

The Mold Temperature Regulator is a compact, simple-to-operate device for heating and maintaining constant mold temperature. It can be difficult to settle a mold into a steady-state condition. Now with the innovative Mold Temperature Regulator, your work is done by your new best friend. You can heat your mold using otherwise wasted energy, and the Mold Temperature Regulator holds your temperature on point regardless of variables thrown its way.



**MOLD TEMP. REGULATOR**

Part Number	Inlet/Outlet	Width	Length	Height	PSI	Weight
<b>WDT2N2N4</b>	¼" NPT inlet and ½" NPT outlet	2.95"	6.02"	1.72"	150	3 lbs.
<b>WDT2S2P2</b>	¼" quick-connect coupler and plug	2.95"	6.02"	1.72"	150	3 lbs.
<b>WDT2S3P3</b>	⅜" quick-connect coupler and plug	2.95"	6.02"	1.72"	150	3 lbs.

- It's unaffected by pressure changes
- It's unaffected by supply water temperature changes
- It reduces the headaches of maintaining different temperature zones
- It's nearly maintenance free
- It saves money up front and conserves energy year-round

Unlike conventional mold temperature controllers, this unit requires no power to operate, relying instead on the tried and true laws of physics to modulate the temperature of molds. The Mold Temperature Regulator indirectly controls mold temperature by modulating the rate of flow of coolant through the mold. It installs, power-free, right on the coolant line exiting the mold. On a basic level, it's really just a fancy thermostat - faster flow removes more heat, cooling the mold; slow flow removes less heat, heating the mold.

On a more technical level, the Mold Temperature Regulator uses thermal expansion with a proprietary heat exchange fluid. The user picks a setpoint with a dial on the Mold Temperature Regulator; a conical valve moves toward or away from the seat to modulate flow, depending upon the setpoint. The device is designed with controlled flow, so that some fluid is always flowing through the Mold Temperature Regulator - that is, you can't shut off coolant flow with the Mold Temperature Regulator. The temperature dial on the Mold Temperature Regulator allows water temperature setpoints from 80°F to 120°F.

## Automatically adjusts for variations in jet water temperature and pressure.

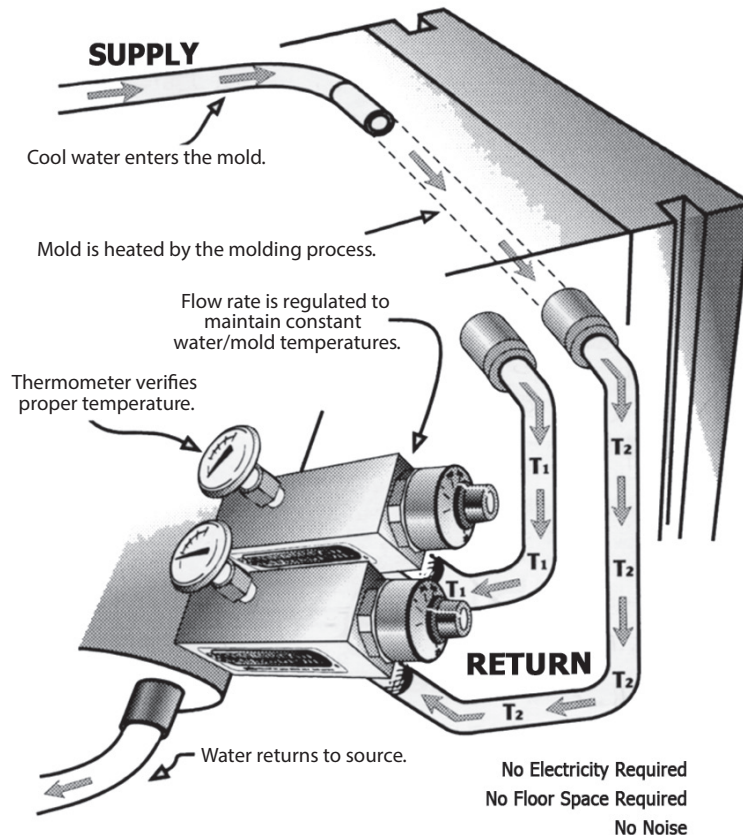

## Tracer with Fluid Characteristic Indication (FCI) Technology

With the new Tracer Electronic Flowmeter, it is easier than ever to know exactly how much water is flowing through your water lines. In addition to flow rate, the Tracer™ provides a precise temperature reading of the water. It will calculate BTU's and display "TFLOW" message when Turbulent Flow is present. With the new information the Tracer™ will provide, you can manage your processes more completely and accurately.

### ELECTRONIC FLOWMETER

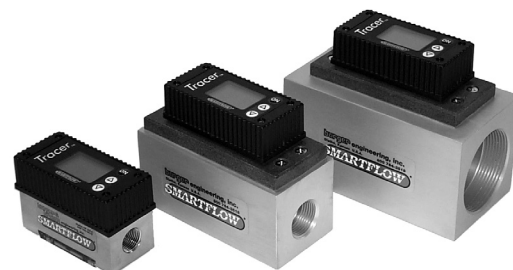

Part No.	Inlet/Outlet	Temp. Range	Temp. Accuracy	Flow	Flow Accuracy	Weight	
DD3B	3/8" NPT inlet and outlet	32°-180°F	+/- 2%	.5 – 8.0 GPM	+/- 5%	1.5 lbs.	
DD3E	3/8" quick-connect coupler and plug						
DD6B	3/4" NPT inlet and outlet			2-20 GPM		2.5 lbs.	
DD6E	3/4" quick-connect coupler and plug						
DD8B	1" NPT inlet and outlet			3-30 GPM		3.9 lbs.	
DD8E	1" quick-connect coupler and plug						
DD12B	1 1/2" NPT inlet and outlet			6.5-60 GPM			
DD12E	1 1/2" quick-connect coupler and plug			10-110 GPM			
DD16B	2" NPT inlet and outlet						
DD16E	2" quick-connect coupler and plug						

#### Know Your Flow

There is no need to guess if water is flowing through each line or zone of a mold. Now you can know exactly how much is flowing. Your flow rate is displayed in 100ths of a gallon per minute. If you prefer, flow is displayed in liters per minute.

#### Know Your Water Temperature

In addition to providing current flow rate data, the Tracer™ also provides the current water temperature at the flowmeter. Used on the supply side, this can verify precise water temperature as it enters the mold. Put the Tracer™ in the out or return side and measure water temperature exiting the mold. Temperature can be displayed in either Fahrenheit or Celsius units, user selectable.

#### Know Your BTU's

The setup mode of the Tracer™ allows you to enter the incoming or supply water temperature. Then with the Tracer™ attached to the return water line, it will calculate BTU per minute.

#### Know Your FCI's

Tracer flowmeter displays a special message ("TFLOW") when Turbulent Flow is present in your cooling water. Turbulent flow is the condition of optimum cooling efficiency. Tracer flowmeter calculates this condition based on the cooling water line size, water temperature and percentage of glycol (0, 10% 20% or 30%) as input in the setup mode.

#### Versatile

The Tracer™ can be mounted in any position. It can accept flow in either direction. 3/8" units include a sight glass on the back for visual verification of flow. Select the optional quick-connect fittings and use the Tracer™ as a test kit to diagnose your water line problems.

#### Digital LCD Display

The digital display Tracer™ is battery powered and has an easy-to-read LCD which displays flow rate, temperature or BTU's at the touch of a button. A programmable auto shutoff feature extends battery life.





# Electronic Flowmeter

## Tracer Switching Flowmeter

### ELECTRONIC FLOWMETER

#### Features and Benefits

- Programmable SPDT switch tied to high or low flow, or high or low temperature conditions to help protect equipment and processes. See Know Your BTUs and FCI on previous page.
- Remotely powered for low maintenance operation
- Bi-directional flow reading makes installation simple and convenient
- Metric or English units for flow and temperature are user-selectable
- Corrosion-resistant wetted parts assure long-lasting durability
- 3/8" through 2" NPT(F) inlet/outlet installs easily into existing plumbing



Tracer® Electronic Switching Flowmeter measures liquid flow rate and temperature while providing one programmable switching set point for high or low flow or temperature. 8 to 28VDC power source operates the flowmeter to provide continuous monitoring of the process. Sealed push-buttons configure the flowmeter and switching operations through user-friendly menus. BTU's per minute and incorporates FCI (Flow Characteristics Indicator) in support of Scientific Cooling<sup>SM</sup> principles.

The Tracer Electronic Switching Flowmeter is designed to be permanently mounted to closely monitor water flow and temperature conditions. The SPDT switch in the Tracer flowmeter can be wired directly to an alarm circuit in a process controller or other peripheral equipment. The NPT(F) threaded openings provide versatile, leak-free connections to match existing plumbing without adapters.

Tracer Flowmeters are suitable for use in injection molding machine cooling water loops, lube oil systems, blending systems, filter condition indicators, and varied applications requiring flow measurement of clean, non-viscous, chemically-compatible process liquids.

Annual calibration is recommended for best results. 3/8" unit not recommended for use with liquids containing metallic particles.

#### Specifications

- Flow accuracy .....±5%\*
  - Flow repeatability .....±3%\*
  - Wetted Parts Body.....Clear-anodized aluminum or nickel-plated brass
  - Impeller.....nylon 6/12
  - Impeller Shaft .....18-8 stainless steel
  - Magnet.....neodymium
  - Power.....8 to 28VDC
  - Switching .....SPDT, 1A, 30VAC, 42VDC
  - Temperature Range.....32°F to 180°F (0°C to 82°C)
  - Accuracy.....±2% of display value
  - Repeatability.....±1% of display value
  - Environmental Pressure.....100 psi max.
- \*Accuracy and repeatability figures are based on the full scale of the range.

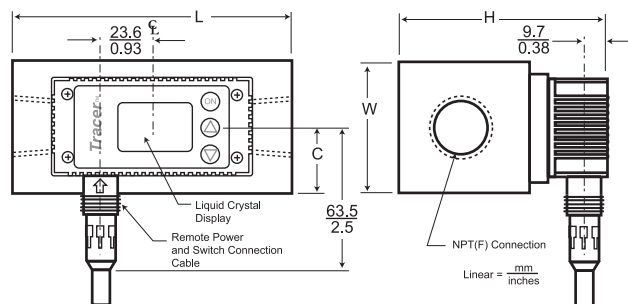

Part Number	Connection Size	Flow Range		Max Dimensions (mm/in)			
		GPM	LPM	L	H	W	C
DDS3B	3/8" NPT(F)	0.5-8	2-30	87/3.42	58/2.27	42/1.67	21/0.83
DDS6B	3/4" NPT(F)	2-20	8-76	121/4.75	94/3.70	57/2.25	29/1.13
DDS8B	1" NPT(F)	3-30	11-114	140/5.50	118/4.65	76/3.00	38/1.50
DDS12B	1-1/2" NPT(F)	6.5-60	25-228				
DDS16B	2" NPT(F)	10-110	38-418				

# Flowmeters



3/4" and 1" NPT

## Features

- Compact, rugged design
- 210°F rating
- 100 PSI
- 20 GPM
- Aluminum body
- Polysulfone sight glass
- Can be mounted in any position
- Optional thermometer & pressure gauge

## Materials & Options

Body.....	Anodized aluminum
Sight glass.....	Polysulfone
Gasket.....	Neoprene
Vane .....	Stainless steel
Spring .....	Stainless steel
Pin & screws .....	Stainless steel
Thermometer (opt.) .....	0° 250°F/-20° -120°C
Pressure gauge (opt.) .....	0 to 100 PSI

Flow

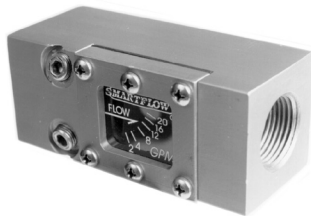

3/4" NPT, 2 to 20 GPM  
**Part Number F6A20**  
 1" NPT, 2 to 20 GPM  
**Part Number F8A20**

Flow & Temp.



3/4" NPT, 2 to 20 GPM  
**Part Number F6B20**  
 1" NPT, 2 to 20 GPM  
**Part Number F8B20**

Flow, Temp. & Pressure



3/4" NPT, 2 to 20 GPM  
**Part Number F6C20**  
 1" NPT, 2 to 20 GPM  
**Part Number F8C20**

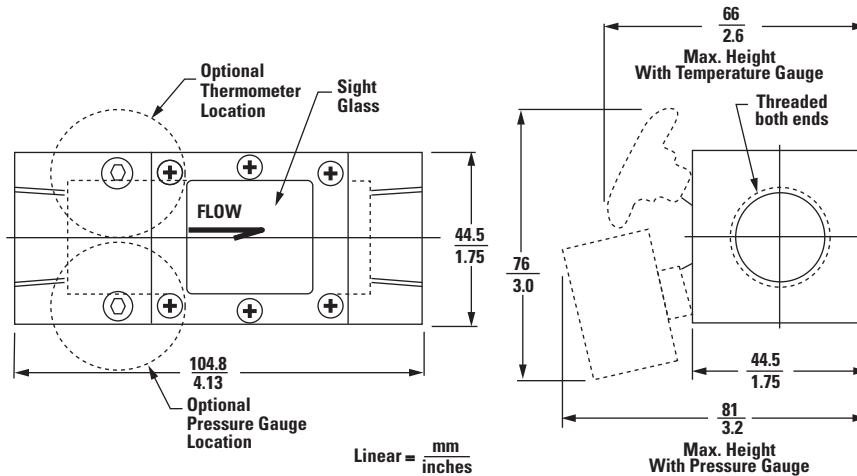





# Large Flowmeters

1" to 2" NPT

Features and materials same as above except that the capacity is up to 100 GPM and rated for 210°F

Flow indicating vane, visible through sight glass, provides continuous flow rate and positive visual verification of flow.

Flow

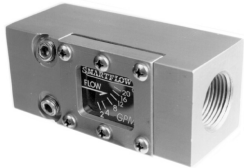

- 1" NPT, 2.5–40 GPM  
**Part Number F8A**
- 1 1/4" NPT, 2.5–40 GPM  
**Part Number F10A**
- 1 1/2" NPT, 2.5–40 GPM  
**Part Number F12A40**
- 1 1/2" NPT, 10–100 GPM  
**Part Number F12A**
- 2" NPT, 2.5–40 GPM  
**Part Number F16A40**
- 2" NPT, 10–100 GPM  
**Part Number F16A**

Flow & Temp.



- 1" NPT, 2.5–40 GPM  
**Part Number F8B**
- 1 1/4" NPT, 2.5–40 GPM  
**Part Number F10B**
- 1 1/2" NPT, 2.5–40 GPM  
**Part Number F12B40**
- 1 1/2" NPT, 10–100 GPM  
**Part Number F12B**
- 2" NPT, 2.5–40 GPM  
**Part Number F16B40**
- 2" NPT, 10–100 GPM  
**Part Number F16B**

Flow, Temp. & Pressure



- 1" NPT, 2.5–40 GPM  
**Part Number F8C**
- 1 1/4" NPT, 2.5–40 GPM  
**Part Number F10C**
- 1 1/2" NPT, 2.5–40 GPM  
**Part Number F12C40**
- 1 1/2" NPT, 10–100 GPM  
**Part Number F12C**
- 2" NPT, 2.5–40 GPM  
**Part Number F16C40**
- 2" NPT, 10–100 GPM  
**Part Number F16C**

## LARGE FLOWMETERS

Dimension Chart	
Dim.	Body Size 1-1/2" or 2"
L	139.7/5.5
H	76.2/3.0
H <sub>1</sub>	99/3.9
H <sub>2</sub>	114/4.5

1" and 1-1/4" Flowmeters 40 gpm

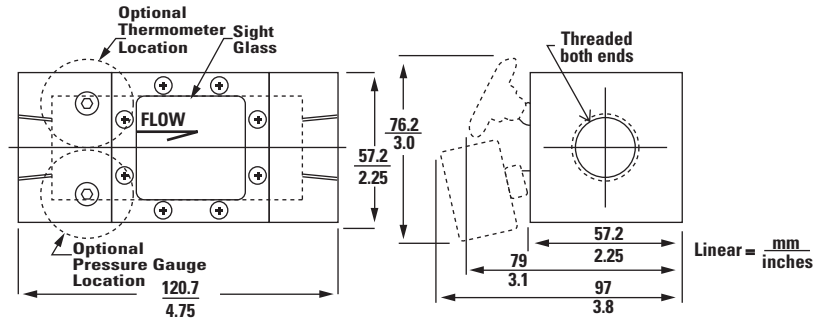

1-1/2", 2" Flowmeters 40, 100

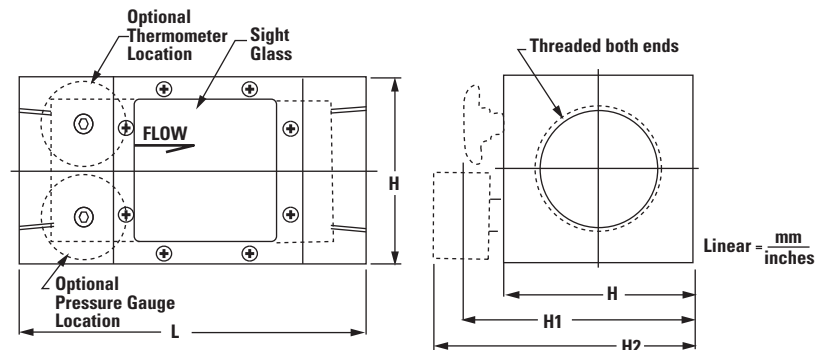

# IceCube™ Flowmeters



## ICECUBE FLOWMETERS

Finally, a product that recognizes that leaks and broken tubes are common problems of other water regulators.

This Smartflow Flowmeter offers a practical and inexpensive solution to a far too common problem.

- Portable
- Compact
- Rugged
- 210°F rating
- 100 PSI
- 1 to 8 GPM – or .5 to 2.5 GPM
- 1/4", 3/8" or 1/2" brass quick connect couplings

on quick-check models.

- Solid brass end caps
- High temperature polymer body
- Can be mounted in any position
- In-stock for same-day shipping
- Material:
  - Endcaps..... Brass
  - Body ..... Polysulfone
  - Vane ..... Nylon
  - Spring..... S/S
  - O-Rings..... EDP
  - Cap Screws ..... S/S

### Flowmeter



#### Smartflow Flowmeter 1 – 8 GPM

- 1/4" NPT ..... **F2A**
- 3/8" NPT ..... **F3A**
- 1/2" NPT ..... **F4A**
- 3/4" NPT ..... **F6A**

#### Smartflow Flowmeter .5 – 2.5 GPM

- 1/4" NPT ..... **SF2A**
- 3/8" NPT ..... **SF3A**
- 1/2" NPT ..... **SF4A**
- 3/4" NPT ..... **SF6A**

### Flow & Temp. & Pressure



#### Smartflow Flow, Temp. & Pressure 1 – 8 GPM

- 1/4" NPT ..... **F2C**
- 3/8" NPT ..... **F3C**
- 1/2" NPT ..... **F4C**
- 3/4" NPT ..... **F6C**

#### Smartflow Flow, Temp. & Pressure .5 – 2.5 GPM

- 1/4" NPT ..... **SF2C**
- 3/8" NPT ..... **SF3C**
- 1/2" NPT ..... **SF4C**
- 3/4" NPT ..... **SF6C**

### Flow & Temp.



#### Flow & Temp. 1 – 8 GPM

- 1/4" NPT ..... **F2B**
- 3/8" NPT ..... **F3B**
- 1/2" NPT ..... **F4B**
- 3/4" NPT ..... **F6B**

#### Flow & Temp. .5 – 2.5 GPM

- 1/4" NPT ..... **SF2B**
- 3/8" NPT ..... **SF3B**
- 1/2" NPT ..... **SF4B**
- 3/4" NPT ..... **SF6B**

### Flow & Pressure



#### Flow & Pressure 1 – 8 GPM

- 1/4" NPT ..... **F2F**
- 3/8" NPT ..... **F3F**
- 1/2" NPT ..... **F4F**
- 3/4" NPT ..... **F6F**

#### Flow & Pressure .5 – 2.5 GPM

- 1/4" NPT ..... **SF2F**
- 3/8" NPT ..... **SF3F**
- 1/2" NPT ..... **SF4F**
- 3/4" NPT ..... **SF6F**

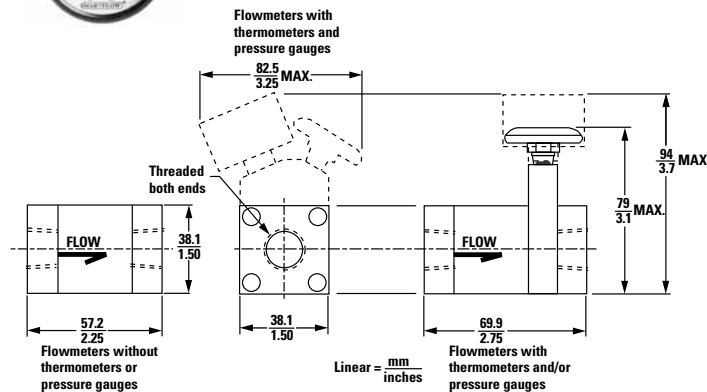



# Ice Cube™ Flowmeters

## With Nylon End Caps

**Reinforced Nylon End Caps reduce weight and cost of proven mechanical flowmeter design.**

Stainless steel stabilizer ring holds threads stable, preventing distortion. Nylon material provides dielectric insulator to help prevent galvanic action due to dissimilar metals.

Stainless Steel Stabilizer Ring!



### General Description

Smartflow® Mechanical Flowmeters are durable, vane-operated devices that provide visual indication of flow rate in many different styles and sizes. Rugged wetted parts are compatible with many process liquids.

Optional temperature and pressure gauges add functionality and flexibility to Smartflow® Flowmeters. Brass quick-connect fittings are available to create an excellent, portable tool for determining flow and locating clogged lines.

### Features and Benefits

- Compact size works well in restricted-space locations
- Rugged construction gives years of dependable service
- Variety of inlet sizes provides exactly the right connection
- 210°F (99°C) temperature rating allows installation into a wide range of applications
- Optional temperature and pressure gauges display pressure and temperature information in addition to flow in one unit
- Common flowmeter configurations stocked to provide same-day delivery in most cases
- No mounting restrictions ease installation in any position without extra brackets or hardware

### Wetted Parts and Materials

End Caps .....	Glass-filled nylon
Flow Body .....	Polysulfone
Vane .....	Glass-filled nylon
Spring .....	Stainless steel
O-Rings.....	EPDM
Cap Screws.....	Stainless steel
Optional Quick-Connect Fittings.....	Brass



### Specifications

Flow Accuracy .....	±10% full scale
Operating Temperature .....	210°F max. (99°C max.)
Operating Pressure.....	100 PSI max. (6.9 bar max.)
Dial Thermometer.....	0° to 250°F (-20° to 120°C) ±2% accuracy (full scale)
Pressure Gauge.....	0 to 100 psi (0 to 700 Kpa) ±3% accuracy (full scale)

# IceCube™ Flowmeters



## With Nylon End Caps

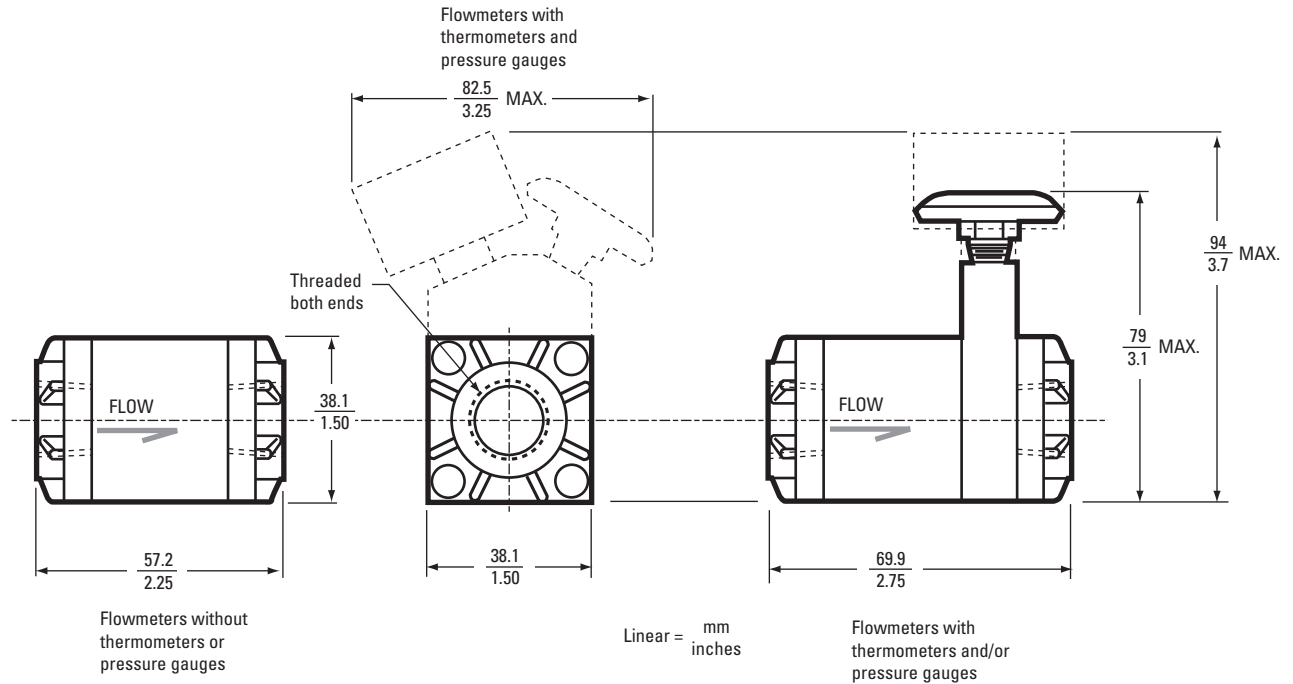

### ICECUBE FLOWMETERS/END CAPS

Part Number	Inlet Size	Accessories
FP2A80	1/4" NPT Female	Flowmeter only
FP2B80		Flowmeter and thermometer
FP2C80		Flowmeter, thermometer and pressure gauge
FP2D80		Flowmeter, thermometer, pressure gauge and quick-change socket and plug
FP2E80		Flowmeter, thermometer and quick-change socket and plug
FP3A80	3/8" NPT Female	Flowmeter only
FP3B80		Flowmeter and thermometer
FP3C80		Flowmeter, thermometer and pressure gauge
FP3D80		Flowmeter, thermometer, pressure gauge and quick-change socket and plug
FP3E80		Flowmeter, thermometer and quick-change socket and plug
FP4A80	1/2" NPT Female	Flowmeter only
FP4B80		Flowmeter and thermometer
FP4C80		Flowmeter, thermometer and pressure gauge
FP4D80		Flowmeter, thermometer, pressure gauge and quick-change socket and plug
FP4E80		Flowmeter, thermometer and quick-change socket and plug

E



# Precision Flow Regulator



Your Platform for Scientific Cooling<sup>SM</sup>

DELTA-Q  
Precision Flow Regulator



## General Description

Delta-Q™ is a low-cost precision flow regulator module that can be used in conjunction with other SMARTFLOW components such as threaded end caps, IceCube™ flowmeters, temperature and pressure gauges, Dr. Eddy® Flowmeter/Turbulent Flow Indicator, Tracer® Electronic Flowmeters, and cooling water manifolds. The Delta-Q Regulator allows full adjustability of flow volume from unrestricted flow to complete shutoff using the manual flow control knob.

The modular design allows users to customize models meeting scientific cooling requirements for each application. The glass-filled nylon body is lightweight and durable. Internal stainless steel components are resistant to corrosion.

## Features and Benefits

- Economical solution for leak-free flow regulation of single or multiple circuits
- Compact size works well in restricted-space locations
- Rugged construction gives years of dependable service
- Variety of inlet sizes provides exactly the right connection
- Optional temperature and pressure gauges give instant access to pressure and temperature information in addition to flow in one unit
- No mounting restrictions ease installation in any position without extra brackets or hardware
- 210°F (99°C) temperature rating allows installation into a wide range of applications





Scientific Molding seeks to optimize molding efficiency by measuring and recording process parameters to the greatest extent possible, providing an effective means of easily repeating a successful molding setup, any molding machine. Mold cooling, estimated to be about 80% of the molding cycle, is a key element.

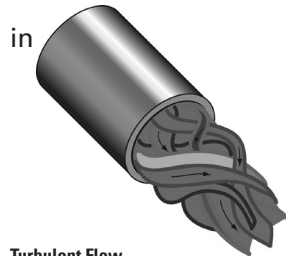

Turbulent Flow

Scientific Cooling<sup>SM</sup> is a training regimen developed for Smartflow<sup>®</sup> products. Scientific

Cooling applies techniques from Scientific Molding: measure, record, adjust and repeat. The teaching of Scientific Cooling requires the right tools to control and quantify cooling parameters. Smartflow's (patent pending) Delta-Q<sup>TM</sup> flow regulator is the foundation of the modular system for Scientific Cooling because it controls and changes flow rate. Delta-Q is designed to mate with Icecube<sup>TM</sup>, Dr. Eddy<sup>®</sup> or Tracer<sup>®</sup> flow meters to provide a range of options for Scientific Cooling measurement and adjustment.

## Measurement options using Delta-Q as your platform for Scientific Cooling:

With an Icecube<sup>TM</sup> Flowmeter  
Attach Delta-Q to a basic mechanical Icecube Flowmeter for economical flexibility of application.



The modular design allows the addition of individual measurement components: temperature gauge, pressure gauge, or liquid-filled pressure gauge. Quick disconnect fittings can also be added to create a portable troubleshooting tool to be kept in a toolbox or mold tryout station. In addition to the parameter

measurements, Delta-Q allows technical molders to experiment with different flow rates while the meter is connected, making Scientific Cooling easier. See next page.

With a Dr. Eddy<sup>®</sup> Flowmeter/Turbulent Flow Indicator Attach Delta-Q to a Dr. Eddy meter to detect turbulent flow using FCI (Flow Characteristic Indication) Technology. The presence of turbulent flow indicates that the most efficient cooling is present. The swirling and mixing of the water inside cooling passages creates the greatest heat transfer from the mold to the cooling medium. When attached to a Dr. Eddy, the Delta-Q becomes a valuable capacity conservation tool. Conserving cooling water at each cooling supply line preserves water capacity in other locations in the shop. Downstream presses can have greater cooling water volume available when upstream cooling line efficiency is maximized. See page 378.

## With a Tracer<sup>®</sup> Electronic Flowmeter

Attach Delta-Q to a Tracer Electronic Flowmeter for greater accuracy and access to FCI Technology<sup>TM</sup>. Tracer flowmeters have  $\pm 5\%$  accuracy and optional NIST traceable calibration. Turbulent flow indication is standard on all Tracer Flowmeters.

A Switching Tracer flowmeter facilitates record-keeping when attached to a PLC or other data collection system. Record keeping is an important step in Scientific Cooling. A Switching Tracer attached to a Delta-Q is the ultimate tool for Scientific Cooling. See page 379.

## On a Smartflow Manifold

Attach an array of Delta-Q modular flow regulators and meters to a Smartflow Manifold for economical fingertip control of an entire mold half without moving individual flowmeters from circuit to circuit. Smartflow manifolds save time in mold setups and help molders start making accurate parts quickly. See page 380.





# Precision Flow Regulator



Use when flow indication is not required.

## Model Number

	<b>F3</b>
Brass End Caps	
1/4" NPT(F)	F2
1/4" BSPP(F)	F2B
3/8" NPT(F)	F3
3/8" BSPP(F)	F3B
1/2" NPT(F)	F4
1/2" BSPP(F)	F4B
Nylon End Caps	
gauge	
1/4" NPT(F)	FP2
1/4" BSPP(F)	FP2B
3/8" NPT(F)	FP3
3/8" BSPP(F)	FP3B
1/2" NPT(F)	FP4
1/2" BSPP(F)	FP4B

<b>A</b>
A
B
C
CL
F
FL

<b>Q</b>	Options
	Regulator only
	Thermometer
	Thermometer and pressure gauge
	Thermometer and liquid-filled pressure gauge
	Pressure gauge
	Liquid-filled pressure



FP3-F-Q

## PRECISION FLOW REGULATOR

### Wetted Parts and Materials

End Caps .....	Brass or glass-filled nylon
Body .....	Glass-filled nylon
O-Rings .....	EPDM
Regulator Stem .....	Stainless steel
Cap Screws .....	Stainless steel
Optional Gauge Block .....	Brass
Optional Quick-Connect Fittings .....	Brass

### Specifications

Operating Temperature .....	210°F max. (99°C max.)
Operating Pressure .....	100 PSI max. (6.9 bar max.)
Dial Thermometer .....	0° to 250°F (-20° to 120°C)
.....	±2% accuracy (full scale)
Pressure Gauge .....	0 to 100 PSI (0 to 700 KPA)
.....	±3% accuracy (full scale)

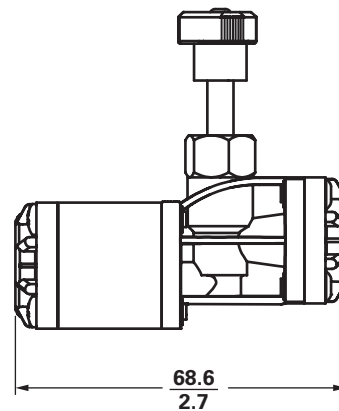
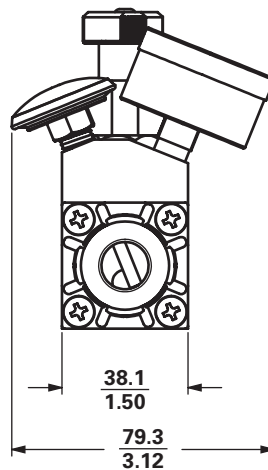
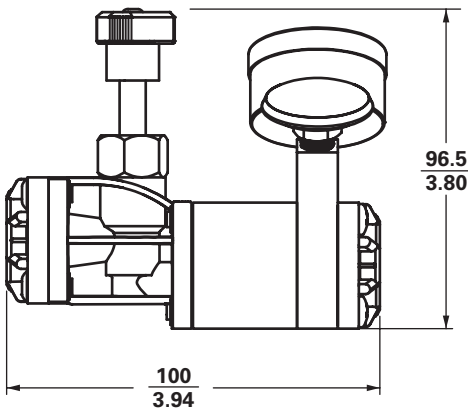

# Regulator IceCube Flowmeter



With IceCube™ Flowmeter

## Model Number

	F3	A	25	QR	
Brass End Caps					Flow Direction
1/4" NPT(F)	F2			QR	Return
1/4" BSPP(F)	F2B				(standard flow in)
3/8" NPT(F)	F3			QS	Supply (flow out)
3/8" BSPP(F)	F3B				
1/2" NPT(F)	F4				Flow Rate (max.)
1/2" BSPP(F)	F4B		15	1.5 GPM	(gallons per minute)
Nylon End Caps					
1/4" NPT(F)	FP2		25	2.5 GPM	
1/4" BSPP(F)	FP2B		80	8.0 GPM	
3/8" NPT(F)	FP3		100	10 LPM	(liters per minute)
3/8" BSPP(F)	FP3B				
1/2" NPT(F)	FP4		200	20 LPM	
1/2" BSPP(F)	FP4B		300	30 LPM	



Use when flow indication is required.

## Options

Flow body only	A
Thermometer	B
Thermometer & press. ga.	C
Thermometer and liquid-filled press. ga.	CL
Thermometer and quick-change socket and plug	E
Pressure gauge	F
Liquid-filled	FL

## Wetted Parts and Materials

End Caps..... Brass or glass-filled nylon  
 Flow Body ..... Polysulfone  
 Regulator Body ..... Glass-filled nylon  
 Vane ..... Glass-filled nylon  
 Spring ..... Stainless steel  
 O-Rings..... EPDM  
 Cap Screws..... Stainless steel  
 Optional Gauge Block..... Brass  
 Optional Quick-Connect Fittings..... Brass

## Specifications

Flow Accuracy ....±10% full scale  
 Operating Temperature 210°F max. (99°C max.)  
 Operating Pressure 100 psi max. (6.9 bar max.)  
 Dial Thermometer.... 0° to 250°F (-20° to 120°C)  
 ..... ±2% accuracy (full scale)  
 Pressure Gauge..... 0 to 100 PSI  
 ..... ±3% accuracy (full scale)

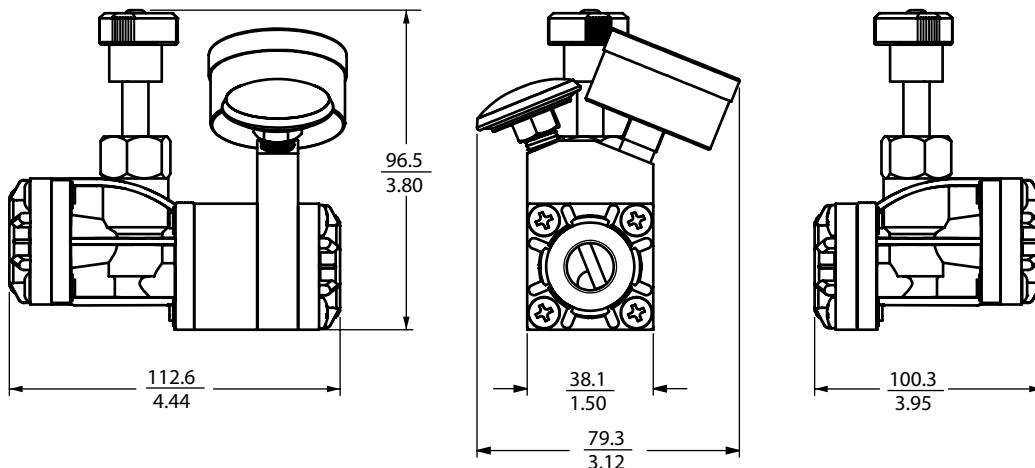



# Precision Flow Regulator

With Dr. Eddy™ Flowmeter



Use when turbulent flow indication is required.

## Model Number

	FC3	B	E	QR	
Brass End Caps					Flow Direction
Inlet Size					Return
1/4" NPT(F)	FC2			QR	(standard flow in)
1/4" BSPP(F)	FC2B				Supply (flow out)
3/8" NPT(F)	FC3				
3/8" BSPP(F)	FC3B			QS	
Nylon End Caps					Scale Units
Inlet Size					E English (temp in °F and flow in GPM)
1/4" NPT(F)	FCP2				M Metric (temp in °C and flow in LPM)
1/4" BSPP(F)	FCP2B				
3/8" NPT(F)	FCP3				
3/8" BSPP(F)	FCP3B				
Accessories					
Thermometer (standard)		B			
Thermometer with quick-connect socket and plug		E			



## PRECISION FLOW/DR. EDDY

### Wetted Parts and Materials

End Caps .....	Brass or glass-filled nylon
Regulator Body .....	Glass-filled nylon
Flow Body .....	Polysulfone
Indicator Ring.....	Silicone rubber
Piston.....	Acetal
Spring .....	Stainless steel
O-Rings.....	EPDM
Gauge Block .....	Brass
Optional Quick-Connect Fittings.....	Brass

### Specifications

Accuracy.....	±10% full scale
Operating Temperature .....	210°F max. (99°C max.)
Operating Pressure.....	100 PSI max. (6.9 bar max.)
Dial Thermometer.....	0° to 250°F (-20° to 120°C)
.....	±2% accuracy (full scale)

10% Glycol Scales are available; contact DME Industrial Supplies for information.

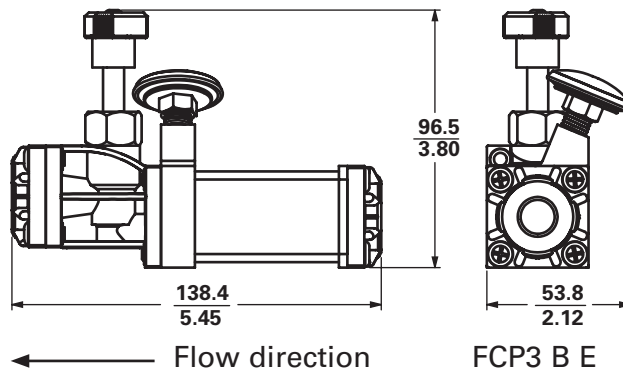

# Precision Flow Regulator



with 3/8" Tracer® Flowmeter

Use when electronic flowmeters are required.

## Model Number

	DD	3BB	Q	
Meter Style	DD			Delta-Q
Digital display	DDS			End Cap
Digital display plus switching			Q QP	Material
				Brass
				Nylon
Thread Size				
	3/8" NPT(F)	3B		
	3/8" BSPP(F)	3BB		



**TRACER FLOWMETER**

Delta-Q Flow Regulator can be used with 3/8" Tracer electronic flowmeters.

### DD - 3.6V Battery-Powered

- Flow rate display
- Temperature display
- BTU's/Minute display
- Turbulent flow condition (with optional glycol % input)

### DDS - 8-28VDC Powered

- Flow rate display
- Temperature display
- BTU's/minute display
- Turbulent flow condition (with optional glycol % input)
- Programmable switch for low and high flow, low and high temperature or turbulent flow condition
- Analog outputs: 0-5VDC or 0-10VDC for flow rate and temperature for connection to a data collection system

### Wetted Parts and Materials

Body.....	Nickel-plated brass
Impeller.....	Nylon
Impeller Shaft.....	Stainless steel
Magnet.....	Neodymium
Back Cover.....	Polysulfone
O-Ring.....	EPDM
End Cap.....	Brass or glass-filled nylon



### Specifications

Flow Accuracy.....	±5% of full scale
Flow Repeatability.....	±3% of full scale
Temperature Accuracy.....	±2% of display
Temperature Repeatability.....	±1% of display
Operating Temperature.....	180°F max. (82°C max.)
Operating Pressure.....	150 PSI max. (10.3 bar max.)

### Power

DD - Model.....	3.6VDC Battery (included)
DDS - Model.....	8 to 28VDC
Switching (DDS - Model only).....	SPDT, 1A 30VAC, 42VDC

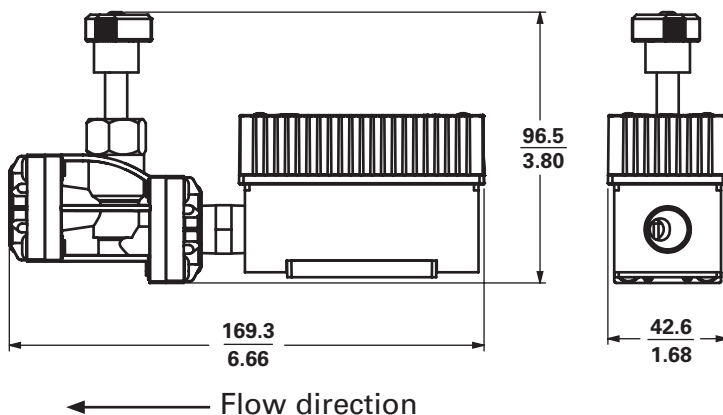





# Precision Flow Regulator

## In Manifold Assemblies



Use when an array of flow regulations is required.

### Model Number

**8SA - 16 - 3 - 2 - AQ B Y - 80**

Base  
Manifold  
Supply size  
and material

3/4" NPT AL	6SA
1" NPT AL	8SA
1-1/2" NPT AL	12SA
2" NPT AL	16SA
1" NPT 304SS	8SS
1-1/2" NPT 304SS	12SS
3/4" BSPP AL	6BSA
1" BSPP AL	8BSA
1-1/2" BSPP AL	12BSA
2" BSPP AL	16BSA
1" BSPP 304SS	8BSS
1-1/2" BSPP 304SS	12BSS

AL= Aluminum  
SS = Stainless steel

Number of Ports 4 to 16

Port Sizes	
1/4" NPT(F)	2
1/4" BSPP(F)	2B
3/8" NPT(F)	3
3/8" BSPP(F)	3B
1/2" NPT(F)	4
1/2" BSPP(F)	4B

Aluminum		Flow Rates
Manifold Color	15	0.2–1.5 GPM
Y Red (flow direction in)	25	0.5–2.5 GPM
80		1–8 GPM
Z Blue (flow direction out);	100	2–10 LPM
does not apply to	200	3–20 LPM
stainless steel	300	4–30 LPM
manifolds		

Flow Regulator	
End Cap Material	
B Brass	
N Nylon	

AQ Temperature Gauge Option without temp. gauge  
TQ with temp. gauge

[CONTACT US](#)



For paired installation, slide aluminum manifolds together using dovetail lock along the side of each manifold. Dovetail feature is not available on 2" aluminum or stainless steel manifolds. Contact DME for options not shown.

**Contact DME Industrial Supplies for options not shown.**

- Available with 1/2", 3/4" & 1" NPT threads
- Easy to install in any position
- No special piping or flow straighteners needed
- No electrical connections
- Direct reading indication

### For Oil, Water & Other Fluids

- Accuracy within ±7% F.S.
- Relatively insensitive to shock and vibration
- Minimal pressure drop

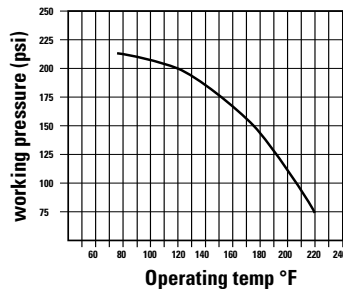

Featuring unique variable-area metering design, with a spring-retained movable piston. The direct-reading EZ-View Flow Meter can be installed quickly, operating within ±7% accuracy. Operates in any position from vertical to horizontal, without costly flow straighteners or other special plumbing requirements. Standard cylindrical walled piston for maximum visibility with opaque liquids. Constructed of polysulfone and stainless steel for greater tolerance to pressure and temperature as well as chemical compatibility, this rugged flow meter is ideal for a wide range of liquid flow monitoring applications, including process control, water cooling systems, hydraulics and many more.



### Specifications

- Material: Polysulfone or brass body and piston with stainless steel spring and stainless steel retaining rings
- Pressure Rating: 220 PSI max. - 3:1 safety factor
- Pressure Drop: Minimal
- Temperature Rating: See "temperature vs pressure" chart above
- Connections: Standard 1" NPT threaded port is recommended; swivel-type brass fittings, with Buna-N

O-rings, are available with 1/2" NPT female and 3/4" NPT male threads; allow easy flow meter removal for routine maintenance.

- Standard scales: Calibrated in graduated GPM and LPM @ .876 specific gravity (oil) and @ 1.0 specific gravity (water) at 70°F.

### EZ VIEW FLOWMETER

Media	Flow Range	Part Number		
		1" Male NPT Polysulfone	3/4" Male NPTF Brass	1/2" Female NPTF Brass
Water 1.0 Sp. Gr.	1.0 – 16 GPM	621-016	625-016	624-016
	3.0 – 18 GPM	621-018	625-018	–
Hex	–	1.125"	1.5"	1.5"
Length	–	5.3" (135 mm)	8.3" (211 mm)	7.8" (198 mm)
Weight	–	3 oz.	1 lb.	1 lb.

\*Do not use pipe dope. Use PTFE tape only.

## Flow Indicators

Visual Flow Indicators provide simple, effective confirmation of coolant flow in mold systems. Prevent dangerous and costly blocked pipe situations.

Visually bright orange spinning rotor  
 Operating temperature 212°F (100°C) max.  
 Pressure 100 PSI max.  
 1/4" or 1/2" ports

Includes low-flow adapter for measuring lower flow rates.

### FLOW INDICATORS



Port Size NPT	Flow range (GPM)		Part Number
	Standard	Low Range	
1/4"	0.5 to 5.0	0.1 to 1.0	<b>VF155420</b>
1/2"	4 to 20	1.5 to 12	<b>VF155480</b>

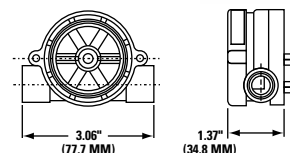



# Dr. Eddy™ Flowmeters

## DR. EDDY FLOWMETER

### Dr. Eddy Diagnoses Flow Condition

Using Fluid Characteristic Indication (FCI) technology, Dr. Eddy displays the condition of the water as it relates to flow efficiency: laminar flow, transitional flow or turbulent flow. Dr. Eddy has four scales built into the meter: three scales for FCI and one scale for flow rate. FCI Scales are selectable and correspond to cooling line inside diameter: 1/4", 3/8", or 1/2". Flow rate scale can be referenced quickly for additional functionality. The flow scale displays flow rate in gallons or liters per minute depending on the model. A dual scale temperature gauge is standard on all models for process comparison to the FCI Scales. Dr. Eddy applies the science of heat transfer, diagnosing the condition of cooling water lines at a glance. Cooling water capacity can be conserved plant-wide by using the minimum amount of flow that will produce turbulence on all presses. It may be possible to delay costly water system upgrades by maximizing the flow effectivity.

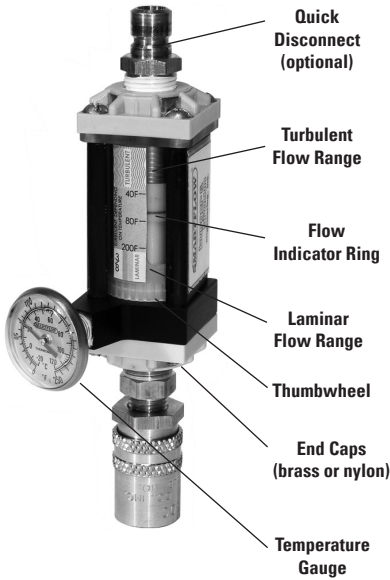

U.S. Patent No. 7,549,348

### Turbulent Flow Basics

Turbulent water flow is much more efficient at removing heat in a cooling system than water flowing under laminar conditions. Once turbulent flow is achieved, increasing the flow rate does not significantly improve the cooling rate of the system. In molding applications, many mold operators try to maximize the flow of water through their cooling systems to ensure turbulent flow. Doing so increases energy costs for pumping more water than necessary through the system. This practice may also limit the amount of cooling water available for cooling additional molds on the same cooling system circuit. By ensuring turbulent flow using FCI Technology, less water can be used in the molding process, saving precious resources.

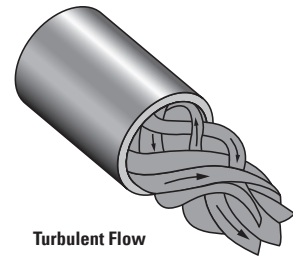

Turbulent Flow

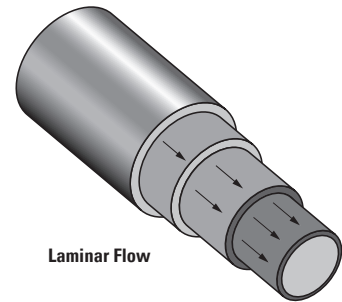

Laminar Flow

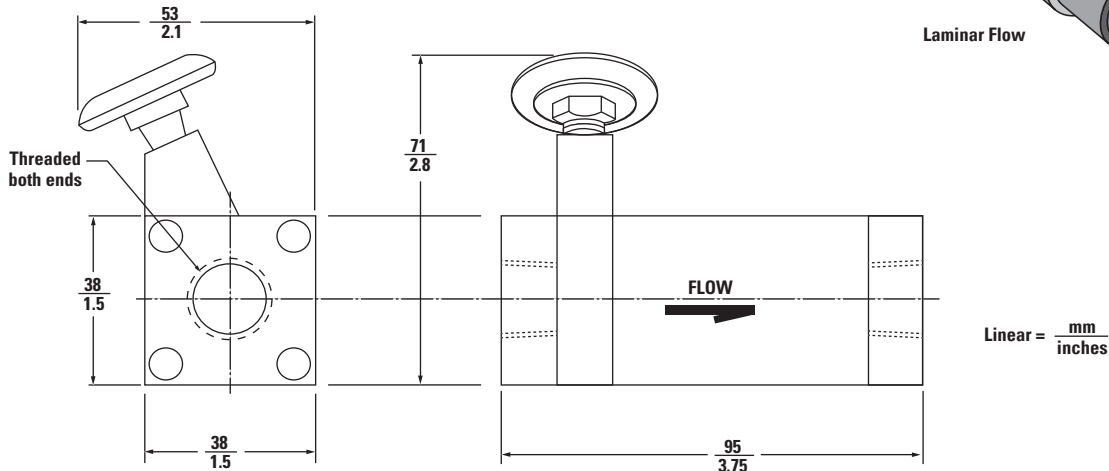

NPT Thread					
Type	Size (of inlet)	Material (of End Caps)	Scale Units	Quick Disconnects?	Part Number
FCI Flowmeter w/temp. and flow gauges	1/4"	Nylon	English (°F)	-	FCP2BE
		Brass		Yes	FCP2EE
				-	FC2BE
		Yes		FC2EE	
	3/8"			Nylon	-
		Brass		Yes	FCP3EE
				-	FC3BE
		Yes		FC3EE	
	1/4"	Nylon	Metric (°C)	-	FCP2BM
				Yes	FCP2EM
		Brass		-	FC2BM
				Yes	FC2EM
3/8"		Nylon		-	FCP3BM
				Yes	FCP3EM
		Brass		-	FC3BM
				Yes	FC3EM
BSP Thread					
Type	Size (of inlet)	Material (of End Caps)	Scale Units	Quick Disconnects?	Part Number
FCI Flowmeter w/temp. and flow gauges	1/4"	Nylon	English (°F)	-	FCP2BBE
		Brass		-	FC2BBE
	3/8"	Nylon		-	FCP3BBE
		Brass		-	FC3BBE
	1/4"	Nylon	Metric (°C)	-	FCP2BBM
		Brass		-	FC2BBM
	3/8"	Nylon		-	FCP3BBM
		Brass		-	FC3BBM



## Flowmeters

Designed to diagnose and/or monitor water line conditions. Provides continuous readings of flow rate, temperature and pressure. Easy to install with quick-connect couplings, one socket and one plug. Choose from a variety of products that help you monitor and adjust your flow, temperature and pressure. End the guesswork, begin the smartwork!

### FLOWMETERS

1 – 8 GPM	
1/4" NPT	F2E
3/8" NPT	F3E
1/2" NPT	F4E
.5 – 2.5 GPM	
1/4" NPT	SF2E
3/8" NPT	SF3E
1/2" NPT	SF4E

1 – 8 GPM	
1/4" NPT	F2D
3/8" NPT	F3D
1/2" NPT	F4D
.5 – 2.5 GPM	
1/4" NPT	SF2D
3/8" NPT	SF3D
1/2" NPT	SF4D

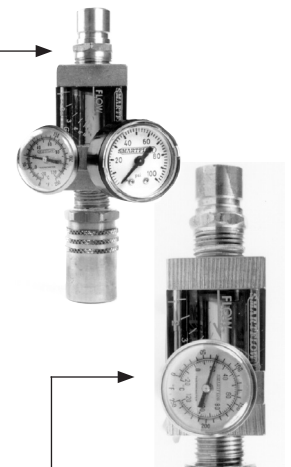



# Flow Regulators

## General Description

Smartflow® Flow Regulators provide a unique, leak-free, single-point manual flow control. This regulator incorporates the proven mechanical flowmeter and integral needle valve in a compact design. Very few moving parts improve reliability and leak-free operation. Used alone or in combination with a water manifold, the flow regulator allows manual control of individual cooling water lines. Brass valve, EPDM o-rings, and polysulfone viewing window are compatible with most process liquids. Optional temperature gauge may be added for additional process control information. Brass quick-connect fittings are available.

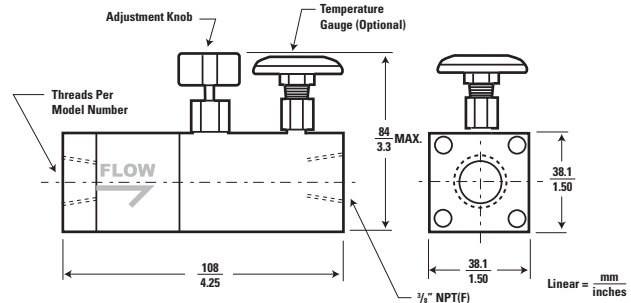

## Features and Benefits

- Compact size works well in restricted-space locations
- Rugged construction gives years of dependable service
- 210°F (99°C) temperature rating allows installation into a wide range of applications
- Optional temperature gauge displays additional process information
- No mounting restrictions ease installation in any position without extra brackets or hardware



## Wetted Parts and Materials

End Caps & Regulator Body.....Brass  
 Flow Body.....Polysulfone  
 Vane.....Glass-filled nylon  
 Spring.....Stainless steel  
 O-Rings.....EPDM  
 Cap Screws.....Stainless steel  
 Optional Quick-Connect Fittings.....Brass

## Specifications

Flow Accuracy.....±10% full scale  
 Operating Temperature.....210°F max.(99°C max.)  
 Operating Pressure.....100 PSI max.(6.9 bar max.)  
 Dial Thermometer.....0° to 250°F(-20° to 120°C) ±2% accuracy (full scale)

## FLOW REGULATORS

Part Number	Description
FR2B15	Flow Regulators -1/4 NPT, 1.5 GPM, includes thermometer
FR3B15	Flow Regulators -3/8 NPT, 1.5 GPM, includes thermometer
FR4B15	Flow Regulators -1/2 NPT, 1.5 GPM, includes thermometer
FR2B25	Flow Regulators -1/4 NPT, 2.5 GPM, includes thermometer
FR3B25	Flow Regulators -3/8 NPT, 2.5 GPM, includes thermometer
FR4B25	Flow Regulators -1/2 NPT, 2.5 GPM, includes thermometer
FR2B100	Flow Regulators -1/4 NPT, 10 LPM, includes thermometer
FR3B100	Flow Regulators -3/8 NPT, 10 LPM, includes thermometer
FR4B100	Flow Regulators -1/2 NPT, 10 LPM, includes thermometer



# Aluminum Water Manifolds



Cooling with ease, DME's one piece aluminum extrusion manifolds allow for outlet ports on 5 flats for maximum water distribution. Painted Blue or Red for easy visual identification of in or out of the manifold, pre-drilled mounting holes.

## Features & Benefits:

Resistant to corrosion, 5 flats for out let ports allows for shorter OAL of the manifold, Combination Red/ Blue in one manifold.)

## Specifications:

One Piece Extruded Aluminum  
 Max Temp up to 180°C/356°F  
 Max Pressure 16Bar/230Psi  
 End Plugs Sold Separately

## ALUMINUM WATER MANIFOLDS

Part Number	Description
BWMBS150	BRACKET FOR 2 BRASS MANIFOLDS WITH 8-16 PORTS
BWMBS70	BRACKET FOR 2 BRASS MANIFOLDS WITH 4 OR 6 PORTS
BWMCC16	ASSEMBLY CLAMP FOR 2 1" BRASS MANIFOLDS
BWMIP12	3/4" INLET PLUG FOR BRASS WATER MANIFOLD
BWMIP16	1" INLET PLUG FOR BRASS WATER MANIFOLD
BWMIP20	1 1/4" INLET PLUG FOR BRASS WATER MANIFOLD
BWMIP24	1 1/2" INLET PLUG FOR BRASS WATER MANIFOLD
BWMIP32	2" INLET PLUG FOR BRASS WATER MANIFOLD
BWMIP8	1/2" INLET PLUG FOR BRASS WATER MANIFOLD

Part Number	Description
ALM4ABC-N2N12-120B	12 PORT ALUM 3/4 INLET 1/8 OUT ABC BLUE 350F 230PSI MAX
ALM4ABC-N2N12-120R	12 PORT ALUM 3/4 INLET 1/8 OUT ABC RED 350F 230PSI MAX
ALM4ABC-N2N12-120RB	6-6 PORT ALUM 3/4 INLET 1/8OUT ABC DIVIDED 350F 230PSI MAX
ALM4ABC-N4N12-120B	12 PORT ALUM 3/4 INLET 1/4 OUT ABC BLUE 350F 230PSI MAX
ALM4ABC-N4N12-120R	12 PORT ALUM 3/4 INLET 1/4 OUT ABC RED 350F 230PSI MAX
ALM4ABC-N4N12-120RB	6-6 PORT ALUM 3/4 INLET 1/4OUT ABC DIVIDED 350F 230PSI MAX
ALM4ABC-N4N16-159B	12 PORT ALUM 1" INLET 1/4 OUT ABC BLUE 350F 230PSI MAX
ALM4ABC-N4N16-159R	12 PORT ALUM 1" INLET 1/4 OUT ABC RED 350F 230PSI MAX
ALM4ABC-N4N16-159RB	6-6 PORT 1" INLET 1/4 OUT ABC DIVIDED 350F 230PSI MAX
ALM4ABC-N6N16-159B	12 PORT ALUM 1" INLET 3/8 OUT ABC BLUE 350F 230PSI MAX
ALM4ABC-N6N16-159R	12 PORT ALUM 1" INLET 3/8 OUT ABC RED 350F 230PSI MAX
ALM4ABC-N6N16-159RB	6-6 PORT 1" INLET 3/8 OUT ABC DIVIDED 350F 230PSI MAX
ALM4ABC-N6N24-254RB	6-6 PORT 1 1/2 INLET 3/8 OUT ABC DIVIDED 350F 230PSI MAX
ALM4ABC-N8N24-254RB	6-6 PORT 1 1/2 INLET 1/2 OUT ABC DIVIDED 350F 230PSI MAX
ALM4BCD-N2N12-120B	12 PORT ALUM 3/4 INLET 1/8 OUT BCD BLUE 350F 230PSI MAX
ALM4BCD-N2N12-120R	12 PORT ALUM 3/4 INLET 1/8 OUT BCD RED 350F 230PSI MAX
ALM4BCD-N4N12-120B	12 PORT ALUM 3/4 INLET 1/4 OUT BCD BLUE 350F 230PSI MAX
ALM4BCD-N4N12-120R	12 PORT ALUM 3/4 INLET 1/4 OUT BCD RED 350F 230PSI MAX
ALM4BCD-N4N16-159B	12 PORT ALUM 1" INLET 1/4 OUT BCD BLUE 350F 230PSI MAX
ALM4BCD-N4N16-159R	12 PORT ALUM 1" INLET 1/4 OUT BCD RED 350F 230PSI MAX
ALM4BCD-N6N16-159B	12 PORT ALUM 1" INLET 3/8 OUT BCD BLUE 350F 230PSI MAX
ALM4BCD-N6N16-159R	12 PORT ALUM 1" INLET 3/8 OUT BCD RED 350F 230PSI MAX
ALM4BCD-N6N24-254B	12 PORT ALUM 1 1/2INLET 3/8OUT BCD BLUE 350F 230PSI MAX
ALM4BCD-N6N24-254R	12 PORT ALUM 1 1/2INLET 3/8OUT BCD RED 350F 230PSI MAX
ALM4BCD-N8N24-254B	12 PORT ALUM 1 1/2INLET 1/2OUT BCD BLUE 350F 230PSI MAX
ALM4BCD-N8N24-254R	12 PORT ALUM 1 1/2INLET 1/2OUT BCD RED 350F 230PSI MAX
ALM4BD-N2N12-120B	8 PORT ALUM 3/4 INLET 1/8 OUT BD BLUE 350F 230PSI MAX
ALM4BD-N2N12-120R	8 PORT ALUM 3/4 INLET 1/8 OUT BD RED 350F 230PSI MAX
ALM4BD-N2N12-120RB	4-4 PORT ALUM 3/4 INLET 1/8OUT BD DIVIDED 350F 230PSI MAX
ALM4BD-N4N12-120B	8 PORT ALUM 3/4 INLET 1/4 OUT BD BLUE 350F 230PSI MAX
ALM4BD-N4N12-120R	8 PORT ALUM 3/4 INLET 1/4 OUT BD RED 350F 230PSI MAX
ALM4BD-N4N12-120RB	4-4 PORT ALUM 3/4 INLET 1/4OUT BD DIVIDED 350F 230PSI MAX
ALM4BD-N4N16-159B	8 PORT ALUM 1" INLET 1/4 OUT BD BLUE 350F 230PSI MAX
ALM4BD-N4N16-159R	8 PORT ALUM 1" INLET 1/4 OUT BD RED 350F 230PSI MAX
ALM4BD-N4N16-159RB	4-4 PORT 1" INLET 1/4 OUT BD DIVIDED 350F 230PSI MAX
ALM4BD-N6N16-159B	8 PORT ALUM 1" INLET 3/8 OUT BD BLUE 350F 230PSI MAX
ALM4BD-N6N16-159R	8 PORT ALUM 1" INLET 3/8 OUT BD RED 350F 230PSI MAX
ALM4BD-N6N16-159RB	4-4 PORT 1" INLET 3/8 OUT BD DIVIDED 350F 230PSI MAX
ALM4BD-N6N24-254B	8 PORT ALUM 1 1/2 INLET 3/8OUT BD BLUE 350F 230PSI MAX
ALM4BD-N6N24-254R	8 PORT ALUM 1 1/2 INLET 3/8OUT BD RED 350F 230PSI MAX
ALM4BD-N6N24-254RB	4-4 PORT 1 1/2 INLET 3/8 OUT BD DIVIDED 350F 230PSI MAX
ALM4BD-N8N24-254B	8 PORT ALUM 1 1/2 INLET 1/2OUT BD BLUE 350F 230PSI MAX
ALM4BD-N8N24-254R	8 PORT ALUM 1 1/2 INLET 1/2OUT BD RED 350F 230PSI MAX
ALM4BD-N8N24-254RB	4-4 PORT 1 1/2 INLET 1/2 OUT BD DIVIDED 350F 230PSI MAX
ALM4C-N2N12-120B	4 PORT ALUM 3/4 INLET 1/8 OUT C BLUE 350F 230PSI MAX
ALM4C-N2N12-120R	4 PORT ALUM 3/4 INLET 1/8 OUT C RED 350F 230PSI MAX
ALM4C-N4N12-120B	4 PORT ALUM 3/4 INLET 1/4 OUT C BLUE 350F 230PSI MAX
ALM4C-N4N12-120R	4 PORT ALUM 3/4 INLET 1/4 OUT C RED 350F 230PSI MAX
ALM4C-N4N16-159B	4 PORT ALUM 1" INLET 1/4 OUT C BLUE 350F 230PSI MAX
ALM4C-N4N16-159R	4 PORT ALUM 1" INLET 1/4 OUT C RED 350F 230PSI MAX
ALM4C-N6N16-159B	4 PORT ALUM 1" INLET 3/8 OUT C BLUE 350F 230PSI MAX
ALM4C-N6N16-159R	4 PORT ALUM 1" INLET 3/8 OUT C RED 350F 230PSI MAX
ALM4C-N6N24-254B	4 PORT ALUM 1 1/2 INLET 3/8OUT C BLUE 350F 230PSI MAX





# Aluminum Water Manifolds

Part Number	Description
ALM4C-N6N24-254R	4 PORT ALUM 1 1/2 INLET 3/8OUT C RED 350F 230PSI MAX
ALM4C-N8N24-254B	4 PORT ALUM 1 1/2 INLET 1/2OUT C BLUE 350F 230PSI MAX
ALM4C-N8N24-254R	4 PORT ALUM 1 1/2 INLET 1/2OUT C RED 350F 230PSI MAX
ALM6ABC-N2N12-171B	18 PORT ALUM 3/4 INLET 1/8 OUT ABC BLUE 350F 230PSI MAX
ALM6ABC-N2N12-171R	18 PORT ALUM 3/4 INLET 1/8 OUT ABC RED 350F 230PSI MAX
ALM6ABC-N2N12-171RB	9-9 PORT ALUM 3/4 INLET 1/8OUT ABC DIVIDED 350F 230PSI MAX
ALM6ABC-N4N12-171B	18 PORT ALUM 3/4 INLET 1/4 OUT ABC BLUE 350F 230PSI MAX
ALM6ABC-N4N12-171R	18 PORT ALUM 3/4 INLET 1/4 OUT ABC RED 350F 230PSI MAX
ALM6ABC-N4N12-171RB	9-9 PORT ALUM 1 1/2 INLET 1/4OUT ABC DIVIDED 350F 230PSI MAX
ALM6ABC-N4N16-222B	18 PORT ALUM 1" INLET 1/4 OUT ABC BLUE 350F 230PSI MAX
ALM6ABC-N4N16-222R	18 PORT ALUM 1" INLET 1/4 OUT ABC RED 350F 230PSI MAX
ALM6ABC-N4N16-222RB	9-9 PORT ALUM 1" INLET 1/4 OUT ABC DIVIDED 350F 230PSI MAX
ALM6ABC-N6N16-222B	18 PORT ALUM 1" INLET 3/8 OUT ABC BLUE 350F 230PSI MAX
ALM6ABC-N6N16-222R	18 PORT ALUM 1" INLET 3/8 OUT ABC RED 350F 230PSI MAX
ALM6ABC-N6N16-222RB	9-9 PORT ALUM 1" INLET 3/8 OUT ABC DIVIDED 350F 230PSI MAX
ALM6ABC-N6N24-355B	18 PORT ALUM 1 1/2 INLET 3/8OUT ABC BLUE 350F 230PSI MAX
ALM6ABC-N6N24-355R	18 PORT ALUM 1 1/2 INLET 3/8OUT ABC RED 350F 230PSI MAX
ALM6ABC-N6N24-355RB	9-9 PORT 1 1/2 INLET 3/8 OUT ABC DIVIDED 350F 230PSI MAX
ALM6ABC-N8N24-355B	18 PORT ALUM 1 1/2 INLET 1/2OUT ABC BLUE 350F 230PSI MAX
ALM6ABC-N8N24-355R	18 PORT ALUM 1 1/2 INLET 1/2OUT ABC RED 350F 230PSI MAX
ALM6ABC-N8N24-355RB	9-9 PORT 1 1/2 INLET 1/2 OUT ABC DIVIDED 350F 230PSI MAX
ALM6BCD-N2N12-171B	18 PORT ALUM 3/4 INLET 1/8 OUT BCD BLUE 350F 230PSI MAX
ALM6BCD-N2N12-171R	18 PORT ALUM 3/4 INLET 1/8 OUT BCD RED 350F 230PSI MAX
ALM6BCD-N4N12-171B	18 PORT ALUM 3/4 INLET 1/4 OUT BCD BLUE 350F 230PSI MAX
ALM6BCD-N4N12-171R	18 PORT ALUM 3/4 INLET 1/4 OUT BCD RED 350F 230PSI MAX
ALM6BCD-N4N16-222B	18 PORT ALUM 1" INLET 1/4 OUT BCD BLUE 350F 230PSI MAX
ALM6BCD-N4N16-222R	18 PORT ALUM 1" INLET 1/4 OUT BCD RED 350F 230PSI MAX
ALM6BCD-N6N16-222B	18 PORT ALUM 1" INLET 3/8 OUT BCD BLUE 350F 230PSI MAX
ALM6BCD-N6N16-222R	18 PORT ALUM 1" INLET 3/8 OUT BCD RED 350F 230PSI MAX
ALM6BCD-N6N24-355B	18 PORT ALUM 1 1/2 INLET 3/8OUT BCD BLUE 350F 230PSI MAX
ALM6BCD-N6N24-355R	18 PORT ALUM 1 1/2 INLET 3/8OUT BCD RED 350F 230PSI MAX
ALM6BCD-N8N24-355B	18 PORT ALUM 1 1/2 INLET 1/2OUT BCD BLUE 350F 230PSI MAX
ALM6BCD-N8N24-355R	18 PORT ALUM 1 1/2 INLET 1/2OUT BCD RED 350F 230PSI MAX
ALM6BD-N2N12-171B	12 PORT ALUM 3/4 INLET 1/8 OUT BD BLUE 350F 230PSI MAX
ALM6BD-N2N12-171R	12 PORT ALUM 3/4 INLET 1/8 OUT BD RED 350F 230PSI MAX
ALM6BD-N2N12-171RB	6-6 PORT ALUM 3/4 INLET 1/8OUT BD DIVIDED 350F 230PSI MAX
ALM6BD-N4N12-171B	12 PORT ALUM 3/4 INLET 1/4 OUT BD BLUE 350F 230PSI MAX
ALM6BD-N4N12-171R	12 PORT ALUM 3/4 INLET 1/4 OUT BD RED 350F 230PSI MAX
ALM6BD-N4N12-171RB	6-6 PORT ALUM 3/4 INLET 1/4OUT BD DIVIDED 350F 230PSI MAX
ALM6BD-N4N16-222B	12 PORT ALUM 1" INLET 1/4 OUT BD BLUE 350F 230PSI MAX
ALM6BD-N4N16-222R	12 PORT ALUM 1" INLET 1/4 OUT BD RED 350F 230PSI MAX
ALM6BD-N4N16-222RB	6-6 PORT ALUM 1" INLET 1/4 OUT BD DIVIDED 350F 230PSI MAX
ALM6BD-N6N16-222B	12 PORT ALUM 1" INLET 3/8 OUT BD BLUE 350F 230PSI MAX
ALM6BD-N6N16-222R	12 PORT ALUM 1" INLET 3/8 OUT BD RED 350F 230PSI MAX
ALM6BD-N6N16-222RB	6-6 PORT ALUM 1" INLET 3/8 OUT BD DIVIDED 350F 230PSI MAX
ALM6BD-N6N24-355B	12 PORT ALUM 1 1/2 INLET 3/8OUT BD BLUE 350F 230PSI MAX
ALM6BD-N6N24-355R	12 PORT ALUM 1 1/2 INLET 3/8OUT BD RED 350F 230PSI MAX
ALM6BD-N6N24-355RB	6-6 PORT 1 1/2 INLET 3/8 OUT BD DIVIDED 350F 230PSI MAX
ALM6BD-N8N24-355B	12 PORT ALUM 1 1/2 INLET 1/2OUT BD BLUE 350F 230PSI MAX
ALM6BD-N8N24-355R	12 PORT ALUM 1 1/2 INLET 1/2OUT BD RED 350F 230PSI MAX
ALM6BD-N8N24-355RB	6-6 PORT 1 1/2 INLET 1/2 OUT BD DIVIDED 350F 230PSI MAX

Part Number	Description
ALM6C-N2N12-171B	6 PORT ALUM 3/4 INLET 1/8 OUT C BLUE 350F 230PSI MAX
ALM6C-N2N12-171R	6 PORT ALUM 3/4 INLET 1/8 OUT C RED 350F 230PSI MAX
ALM6C-N4N12-171B	6 PORT ALUM 3/4 INLET 1/4 OUT C BLUE 350F 230PSI MAX
ALM6C-N4N12-171R	6 PORT ALUM 3/4 INLET 1/4 OUT C RED 350F 230PSI MAX
ALM6C-N4N16-222B	6 PORT ALUM 1" INLET 1/4 OUT C BLUE 350F 230PSI MAX
ALM6C-N4N16-222R	6 PORT ALUM 1" INLET 1/4 OUT C RED 350F 230PSI MAX
ALM6C-N6N16-222B	6 PORT ALUM 1" INLET 3/8 OUT C BLUE 350F 230PSI MAX
ALM6C-N6N16-222R	6 PORT ALUM 1" INLET 3/8 OUT C RED 350F 230PSI MAX
ALM6C-N6N24-355B	6 PORT ALUM 1 1/2 INLET 3/8OUT C BLUE 350F 230PSI MAX
ALM6C-N6N24-355R	6 PORT ALUM 1 1/2 INLET 3/8OUT C RED 350F 230PSI MAX
ALM6C-N8N24-355B	6 PORT ALUM 1 1/2 INLET 1/2OUT C BLUE 350F 230PSI MAX
ALM6C-N8N24-355R	6 PORT ALUM 1 1/2 INLET 1/2OUT C RED 350F 230PSI MAX
ALM8ABC-N2N12-222RB	12-12 PORT 3/4 INLET 1/8 OUT ABC DIVIDED 350F 230PSI MAX
ALM8ABC-N4N12-222RB	12-12 PORT 3/4 INLET 1/4 OUT ABC DIVIDED 350F 230PSI MAX
ALM8ABC-N4N16-286RB	12-12 PORT 1" INLET 1/4 OUT ABC DIVIDED 350F 230PSI MAX
ALM8ABC-N6N16-286RB	12-12 PORT 1" INLET 3/8 OUT ABC DIVIDED 350F 230PSI MAX
ALM8ABC-N6N24-457RB	12-12 PORT 1 1/2 INLET 3/8 OUT ABC DIVIDED 350F 230PSI MAX
ALM8ABC-N8N24-457RB	12-12 PORT 1 1/2 INLET 1/2 OUT ABC DIVIDED 350F 230PSI MAX
ALM8BD-N2N12-222B	16 PORT ALUM 3/4 INLET 1/8 OUT BD BLUE 350F 230PSI MAX
ALM8BD-N2N12-222R	16 PORT ALUM 3/4 INLET 1/8 OUT BD RED 350F 230PSI MAX
ALM8BD-N2N12-222RB	8-8 PORT ALUM 3/4 INLET 1/8OUT BD DIVIDED 350F 230PSI MAX
ALM8BD-N4N12-222B	16 PORT ALUM 3/4 INLET 1/4 OUT BD BLUE 350F 230PSI MAX
ALM8BD-N4N12-222R	16 PORT ALUM 3/4 INLET 1/4 OUT BD RED 350F 230PSI MAX
ALM8BD-N4N12-222RB	8-8 PORT ALUM 3/4 INLET 1/4OUT BD DIVIDED 350F 230PSI MAX
ALM8BD-N4N16-286B	16 PORT ALUM 1" INLET 1/4 OUT BD BLUE 350F 230PSI MAX
ALM8BD-N4N16-286R	16 PORT ALUM 1" INLET 1/4 OUT BD RED 350F 230PSI MAX
ALM8BD-N4N16-286RB	8-8 PORT ALUM 1" INLET 1/4 OUT BD DIVIDED 350F 230PSI MAX
ALM8BD-N6N16-286B	16 PORT ALUM 1" INLET 3/8 OUT BD BLUE 350F 230PSI MAX
ALM8BD-N6N16-286R	16 PORT ALUM 1" INLET 3/8 OUT BD RED 350F 230PSI MAX
ALM8BD-N6N16-286RB	8-8 PORT ALUM 1" INLET 3/8 OUT BD DIVIDED 350F 230PSI MAX
ALM8BD-N6N24-457B	16 PORT ALUM 1 1/2 INLET 3/8OUT BD BLUE 350F 230PSI MAX
ALM8BD-N6N24-457R	16 PORT ALUM 1 1/2 INLET 3/8OUT BD RED 350F 230PSI MAX
ALM8BD-N6N24-457RB	8-8 PORT 1 1/2 INLET 3/8 OUT BD DIVIDED 350F 230PSI MAX
ALM8BD-N8N24-457B	16 PORT ALUM 1 1/2 INLET 1/2OUT BD BLUE 350F 230PSI MAX
ALM8BD-N8N24-457R	16 PORT ALUM 1 1/2 INLET 1/2OUT BD RED 350F 230PSI MAX
ALM8BD-N8N24-457RB	8-8 PORT 1 1/2 INLET 1/2 OUT BD DIVIDED 350F 230PSI MAX
ALM8C-N2N12-222B	8 PORT ALUM 3/4 INLET 1/8 OUT C BLUE 350F 230PSI MAX
ALM8C-N2N12-222R	8 PORT ALUM 3/4 INLET 1/8 OUT C RED 350F 230PSI MAX
ALM8C-N4N12-222B	8 PORT ALUM 3/4 INLET 1/4 OUT C BLUE 350F 230PSI MAX
ALM8C-N4N12-222R	8 PORT ALUM 3/4 INLET 1/4 OUT C RED 350F 230PSI MAX
ALM8C-N4N16-286B	8 PORT ALUM 1" INLET 1/4 OUT C BLUE 350F 230PSI MAX
ALM8C-N4N16-286R	8 PORT ALUM 1" INLET 1/4 OUT C RED 350F 230PSI MAX
ALM8C-N6N16-286B	8 PORT ALUM 1" INLET 3/8 OUT C BLUE 350F 230PSI MAX
ALM8C-N6N16-286R	8 PORT ALUM 1" INLET 3/8 OUT C RED 350F 230PSI MAX
ALM8C-N6N24-457B	8 PORT ALUM 1 1/2 INLET 3/8OUT C BLUE 350F 230PSI MAX
ALM8C-N6N24-457R	8 PORT ALUM 1 1/2 INLET 3/8OUT C RED 350F 230PSI MAX
ALM8C-N8N24-457B	8 PORT ALUM 1 1/2 INLET 1/2OUT C BLUE 350F 230PSI MAX
ALM8C-N8N24-457R	8 PORT ALUM 1 1/2 INLET 1/2OUT C RED 350F 230PSI MAX

# Brass Water Manifolds



Part Number	Description
BWM10412B	BRASS 10 1/4 PORTS 3/4 INLET BLUE 350F 230PSI MAX
BWM10412R	BRASS 10 1/4 PORTS 3/4 INLET RED 350F 230PSI MAX
BWM10612B	BRASS 10 3/8 PORTS 3/4 INLET BLUE 350F 230PSI MAX
BWM10612R	BRASS 10 3/8 PORTS 3/4 INLET RED 350F 230PSI MAX
BWM10616B	BRASS 10 3/8 PORTS 1INCH INLET BLUE 350F 230PSI MAX
BWM10616R	BRASS 10 3/8 PORTS 1INCH INLET RED 350F 230PSI MAX
BWM10620B	BRASS 10 3/8 PORTS 1 1/4 INLET BLUE 350F 230PSI MAX
BWM10620R	BRASS 10 3/8 PORTS 1 1/4 INLET RED 350F 230PSI MAX
BWM10816B	BRASS 10 1/2 PORTS 1INCH INLET BLUE 350F 230PSI MAX
BWM10816R	BRASS 10 1/2 PORTS 1INCH INLET RED 350F 230PSI MAX
BWM10820B	BRASS 10 1/2 PORTS 1 1/4 INLET BLUE 350F 230PSI MAX
BWM10820R	BRASS 10 1/2 PORTS 1 1/4 INLET RED 350F 230PSI MAX
BWM12412B	BRASS 12 1/4 PORTS 3/4 INLET BLUE 350F 230PSI MAX
BWM12412R	BRASS 12 1/4 PORTS 3/4 INLET RED 350F 230PSI MAX
BWM12612B	BRASS 12 3/8 PORTS 3/4 INLET BLUE 350F 230PSI MAX
BWM12612R	BRASS 12 3/8 PORTS 3/4 INLET RED 350F 230PSI MAX
BWM12616B	BRASS 12 3/8 PORTS 1INCH INLET BLUE 350F 230PSI MAX
BWM12616R	BRASS 12 3/8 PORTS 1INCH INLET RED 350F 230PSI MAX
BWM12620B	BRASS 12 3/8 PORTS 1 1/4 INLET BLUE 350F 230PSI MAX
BWM12620R	BRASS 12 3/8 PORTS 1 1/4 INLET RED 350F 230PSI MAX
BWM12816B	BRASS 12 1/2 PORTS 1INCH INLET BLUE 350F 230PSI MAX
BWM12816R	BRASS 12 1/2 PORTS 1INCH INLET RED 350F 230PSI MAX
BWM12820B	BRASS 12 1/2 PORTS 1 1/4 INLET BLUE 350F 230PSI MAX
BWM12820R	BRASS 12 1/2 PORTS 1 1/4 INLET RED 350F 230PSI MAX
BWM16620B	BRASS 16 3/8 PORTS 1 1/4 INLET BLUE 350F 230PSI MAX
BWM16620R	BRASS 16 3/8 PORTS 1 1/4 INLET RED 350F 230PSI MAX
BWM16820B	BRASS 16 1/2 PORTS 1 1/4 INLET BLUE 350F 230PSI MAX
BWM16820R	BRASS 16 1/2 PORTS 1 1/4 INLET RED 350F 230PSI MAX
BWM4412B	BRASS 4 1/4 PORTS 3/4 INLET BLUE 350F 230PSI MAX
BWM4412R	BRASS 4 1/4 PORTS 3/4 INLET RED 350F 230PSI MAX
BWM4612B	BRASS 4 3/8 PORTS 3/4 INLET BLUE 350F 230PSI MAX
BWM4612R	BRASS 4 3/8 PORTS 3/4 INLET RED 350F 230PSI MAX
BWM4616B	BRASS 4 3/8 PORTS 1 INCH INLET BLUE 350F 230PSI MAX
BWM4616R	BRASS 4 3/8 PORTS 1 INCH INLET RED 350F 230PSI MAX
BWM4620B	BRASS 4 3/8 PORTS 1 1/4 INLET BLUE 350F 230PSI MAX
BWM4620R	BRASS 4 3/8 PORTS 1 1/4 INLET RED 350F 230PSI MAX
BWM4816B	BRASS 4 1/2 PORTS 1 INCH INLET BLUE 350F 230PSI MAX
BWM4816R	BRASS 4 1/2 PORTS 1 INCH INLET RED 350F 230PSI MAX
BWM4820B	BRASS 4 1/2 PORTS 1 1/4 INLET BLUE 350F 230PSI MAX
BWM4820R	BRASS 4 1/2 PORTS 1 1/4 INLET RED 350F 230PSI MAX
BWM6412B	BRASS 6 1/4 PORTS 3/4 INLET BLUE 350F 230PSI MAX
BWM6412R	BRASS 6 1/4 PORTS 3/4 INLET RED 350F 230PSI MAX
BWM6612B	BRASS 6 3/8 PORTS 3/4 INLET BLUE 350F 230PSI MAX
BWM6612R	BRASS 6 3/8 PORTS 3/4 INLET RED 350F 230PSI MAX
BWM6616B	BRASS 6 3/8 PORTS 1 INCH INLET BLUE 350F 230PSI MAX
BWM6616R	BRASS 6 3/8 PORTS 1 INCH INLET RED 350F 230PSI MAX
BWM6620B	BRASS 6 3/8 PORTS 1 1/4 INLET BLUE 350F 230PSI MAX
BWM6620R	BRASS 6 3/8 PORTS 1 1/4 INLET RED 350F 230PSI MAX
BWM6816B	BRASS 6 1/2 PORTS 1 INCH INLET BLUE 350F 230PSI MAX
BWM6816R	BRASS 6 1/2 PORTS 1 INCH INLET RED 350F 230PSI MAX
BWM6820B	BRASS 6 1/2 PORTS 1 1/4 INLET BLUE 350F 230PSI MAX
BWM6820R	BRASS 6 1/2 PORTS 1 1/4 INLET RED 350F 230PSI MAX
BWM8412B	BRASS 8 1/4 PORTS 3/4 INLET BLUE 350F 230PSI MAX



Brass is a great alternative to aluminum manifolds. Aluminum is known to erode when introduced to acidic water and harsh water. Brass manifolds are also unaffected by galvanic corrosion caused by aluminum manifolds combined with brass fittings. Overtime this erosion can lead to leaks of the threaded in/outlets.

### Features & Benefits:

Resistant to corrosion, Painted color coded to quickly identify in and out of mold. Many options for inlet and outlet threads and number of ports to easily connect to your mold.

### Specifications:

- High Quality Brass Alloy
- Max Temps up to 180°C/356°F
- Max Pressure 16Bar/230Psi
- End Plugs Sold Separately

## BRASS WATER MANIFOLDS

Part Number	Description
BWM8412R	BRASS 8 1/4 PORTS 3/4 INLET RED 350F 230PSI MAX
BWM8612B	BRASS 8 3/8 PORTS 3/4 INLET BLUE 350F 230PSI MAX
BWM8612R	BRASS 8 3/8 PORTS 3/4 INLET RED 350F 230PSI MAX
BWM8616B	BRASS 8 3/8 PORTS 1 INCH INLET BLUE 350F 230PSI MAX
BWM8616R	BRASS 8 3/8 PORTS 1 INCH INLET RED 350F 230PSI MAX
BWM8620B	BRASS 8 3/8 PORTS 1 1/4 INLET BLUE 350F 230PSI MAX
BWM8620R	BRASS 8 3/8 PORTS 1 1/4 INLET RED 350F 230PSI MAX
BWM8816B	BRASS 8 1/2 PORTS 1 INCH INLET BLUE 350F 230PSI MAX
BWM8816R	BRASS 8 1/2 PORTS 1 INCH INLET RED 350F 230PSI MAX
BWM8820B	BRASS 8 1/2 PORTS 1 1/4 INLET BLUE 350F 230PSI MAX
BWM8820R	BRASS 8 1/2 PORTS 1 1/4 INLET RED 350F 230PSI MAX
BWMBS150	BRACKET FOR 2 BRASS MANIFOLDS WITH 8-16 PORTS
BWMBS70	BRACKET FOR 2 BRASS MANIFOLDS WITH 4 OR 6 PORTS
BWMCC16	ASSEMBLY CLAMP FOR 2 1" BRASS MANIFOLDS
BWMI12	3/4" INLET PLUG FOR BRASS WATER MANIFOLD
BWMI16	1" INLET PLUG FOR BRASS WATER MANIFOLD
BWMI20	1 1/4" INLET PLUG FOR BRASS WATER MANIFOLD
BWMI24	1 1/2" INLET PLUG FOR BRASS WATER MANIFOLD
BWMI32	2" INLET PLUG FOR BRASS WATER MANIFOLD
BWMI8	1/2" INLET PLUG FOR BRASS WATER MANIFOLD



# Aluminum Manifolds

## INTERLOCKING ALUMINUM MANIFOLDS

### Features & Benefits:

- One-piece aluminum extrusion
- Anodized red and blue for corrosion protection
- No welds
- No rust
- 3/4", 1" or 1 1/2" NPT supply
- 1/4", 3/8" or 1/2" ports
- Brass end plug included
- Pre-drilled mounting holes and screws
- Interlocking units



**Made in the USA!**

Part Number	No. Ports	NPT Port Size	Length	Inlet NPT	Between Ports
<b>3/4" NPT Inlet/Outlet with 1/4" NPT Ports</b>					
6SA4-2	4	1/4"	7.5"	3/4"	1 1/2"
6SA6-2	6	1/4"	10.5"	3/4"	1 1/2"
6SA8-2	8	1/4"	13.5"	3/4"	1 1/2"
*6SA10-2	10	1/4"	16.5"	3/4"	1 1/2"
*6SA12-2	12	1/4"	19.5"	3/4"	1 1/2"
*6SA16-2	16	1/4"	25.5"	3/4"	1 1/2"
<b>3/4" NPT Inlet/Outlet with 3/8" NPT Ports</b>					
6SA4-3	4	3/8"	9"	3/4"	2"
6SA6-3	6	3/8"	13"	3/4"	2"
6SA8-3	8	3/8"	17"	3/4"	2"
*6SA10-3	10	3/8"	21"	3/4"	2"
*6SA12-3	12	3/8"	25"	3/4"	2"
*6SA16-3	16	3/8"	33"	3/4"	2"
<b>1" NPT Inlet/Outlet with 1/4" NPT Ports</b>					
SA4-2	4	1/4"	7.5"	1"	1 1/2"
SA6-2	6	1/4"	10.5"	1"	1 1/2"
SA8-2	8	1/4"	13.5"	1"	1 1/2"
SA10-2	10	1/4"	16.5"	1"	1 1/2"
SA12-2	12	1/4"	19.5"	1"	1 1/2"
SA16-2	16	1/4"	25.5"	1"	1 1/2"
<b>1" NPT Inlet/Outlet with 3/8" NPT Ports</b>					
SA4-3	4	3/8"	9"	1"	2"
SA6-3	6	3/8"	13"	1"	2"
SA8-3	8	3/8"	17"	1"	2"
SA10-3	10	3/8"	21"	1"	2"
SA12-3	12	3/8"	25"	1"	2"
SA16-3	16	3/8"	33"	1"	2"
<b>1-1/2" NPT Inlet/Outlet with 1/2" NPT Ports</b>					
12SA4-4	4	1/2"	10"	1-1/2"	2"
12SA6-4	6	1/2"	14"	1-1/2"	2"
12SA8-4	8	1/2"	18"	1-1/2"	2"
12SA10-4	10	1/2"	22"	1-1/2"	2"
12SA12-4	12	1/2"	26"	1-1/2"	2"
12SA16-4	16	1/2"	34"	1-1/2"	2"

### Available Options:

- 1/2" ball valves
- 1/2" quick change plugs
- 1/2" hose barbs
- Flowmeters
- Flow Regulators
- 1 1/2" or 2" supply/hose barb fittings
- Custom modifications

☐ Add "R" for red or "B" for blue.

368 U.S. 800-626-6653 • Canada 800-387-6600 • Mexico 52-442-7135666 • Worldwide 248-398-6000

# Aluminum Manifolds



2" female NPT manifold allows tremendous flow. This large manifold supplies up to 16-1/2" ports uniformly without restricting flow.

**Specify Red or Blue by adding -R or -B to Part Number!**

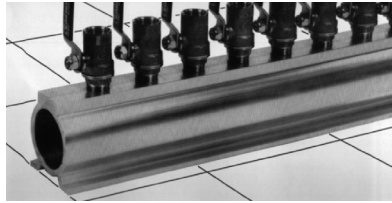

- One piece aluminum extrusion
- Anodized for corrosion protection
- No welds
- No rust
- 2" NPT supply for maximum flow
- 1/2" ports - up to 1" available
- Brass end plug included
- Integral mounting flange
- With or without flow
- Money back guarantee

Available Options:

- 1/2" ball valves
- 1/2" quick change plugs
- 1/2" hose barbs
- Flowmeters
- Flow Regulators
- Custom modifications

Made in the USA!

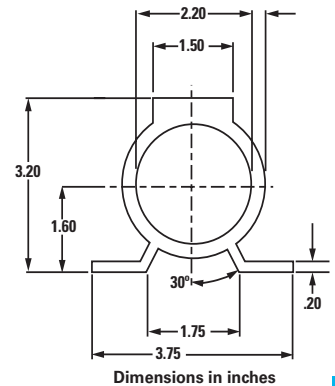

## INTERLOCKING ALUMINUM MANIFOLDS

Part Number*	No. of Ports	2" Manifolds With 1/2" Ports Length
A4A <sup>?</sup>	4	10"
A6A <sup>?</sup>	6	14"
A8A <sup>?</sup>	8	18"
A12A <sup>?</sup>	12	26"
A16A <sup>?</sup>	16	34"

Manifolds include a brass end plug. Add "R" for red or "B" for blue.

## SMARTFLOW<sup>®</sup> Standard Aluminum Manifold Dimensions

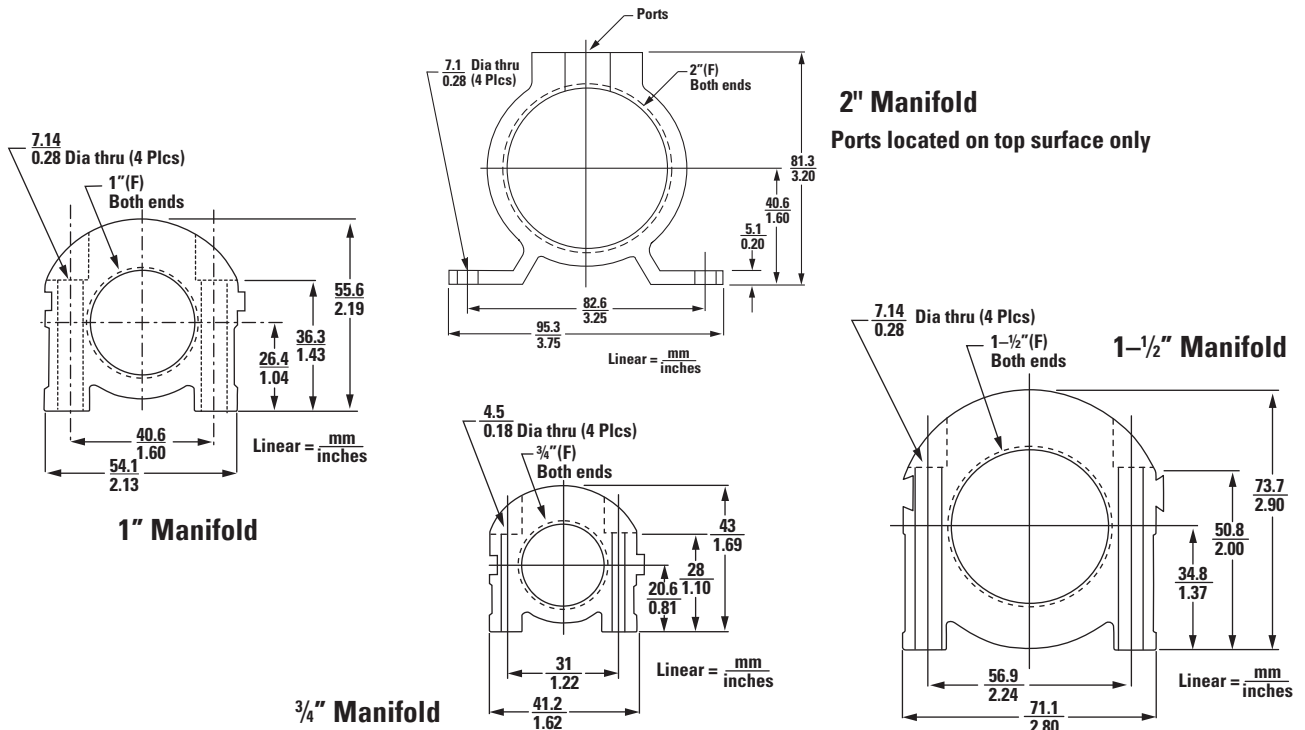





# SMARTFLOW®

## DUOFLOW™ Aluminum Manifolds

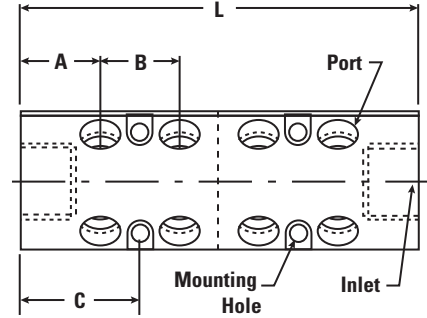

See table below for dimensions.

### SMARTFLOW-DUOFLOW ALUMINUM MANIFOLDS

#### General Description

SMARTFLOW® DUOFLOW™ Manifolds are robust extruded aluminum manifolds similar to the original Smartflow one-piece design. The manifolds are divided internally and anodized with one red end and one blue end to denote supply and return on a single manifold.

The Duoflow design provides a shorter footprint specifically for mounting a manifold directly to an injection mold, or where space is limited. Port spacing is narrow for installation of hose barbs or quick disconnect fittings only. Ball valves are not recommended.

Tool change time is significantly decreased by mounting manifolds directly to molds in storage. Water hookup is simplified to "Supply" and "Return" lines versus individual water lines for every circuit.

#### Features and Benefits

- Versatile mounting due to smaller size
- Mold-Mount to speed mold change times
- Economical, proven design for reliability

#### Specifications

Max. Pressure .....150 PSI (10 bar)  
 Max. Temperature ..... 210°F (99°C)  
 Material .....Aluminum  
 Divider Material ..... Stainless Steel w EPD

Custom manifolds are available on request!

#### Stocked Manifolds

Model Number	Inlet Size	Port Size	Total Ports	Ports Per End	A	B	C	Overall Length L
6SDA8-2-13AYZ	¾" NPT	¼" NPT	8	4	1" 25.4mm	1" 25.4mm	1.5" 38mm	6.0"/152mm
6SDA12-2-13AYZ			12	6				8.0"/203mm
6SDA16-2-13AYZ			16	8				10.0"/254mm
8SDA8-3-13AYZ	1" NPT	⅜" NPT	8	4	1.25" 32mm	1.25" 32mm	1.88" 47.6mm	7.25"/184mm
8SDA12-3-13AYZ			12	6				9.75"/248mm
8SDA16-3-13AYZ			16	8				12.25"/311mm
12SDA8-4-13AYZ	1-½" NPT	½" NPT	8	4	1.75" 44.5mm	1.5" 38mm	2.5" 63.5mm	9.0"/229mm
12SDA12-4-13AYZ			12	6				12.0"/305mm
12SDA16-4-13AYZ			16	8				15.0"/381mm

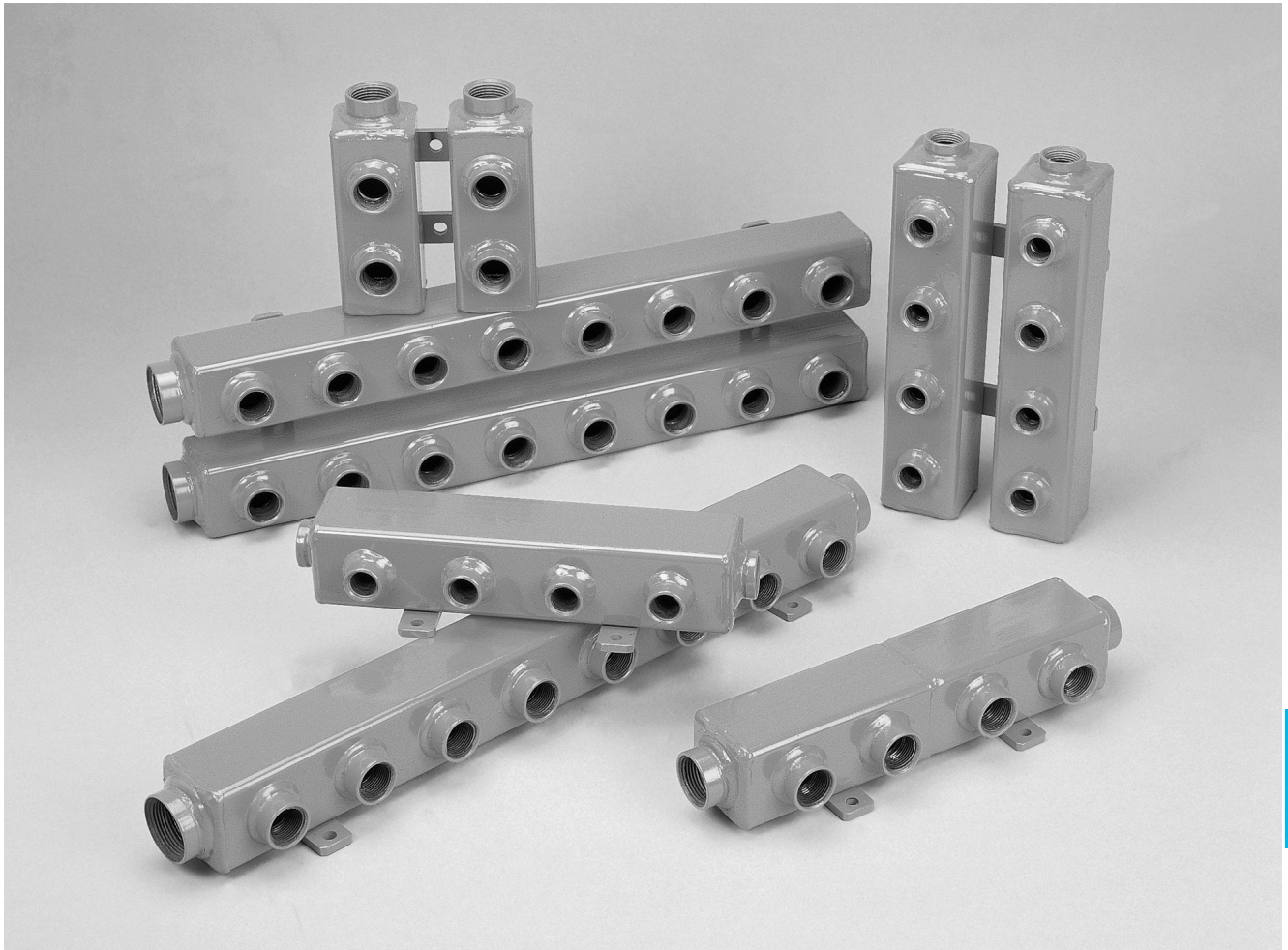

E

### Painted Steel Manifolds

Painted steel water manifolds help increase cycles through more efficient water distribution. They help tidy your hoses while reducing the number of hoses to mold. Mount the manifolds close to your mold for maximum flow volumes. Platen-mounted manifolds reduce hose lengths (if you plan to keep platen-mounted manifolds in storage with your mold, we recommend that you select our anodized aluminum or stainless steel manifolds).

Manufactured from heavy gauge mild steel with threaded couplings welded in place. Pre-drilled mounting brackets for easy mounting to your mold platens or temperature controller are included.

### Stainless Steel Manifolds

All the benefits of our painted steel manifolds – better water distribution for increased cycles, reduced number of hoses, tidier hose arrangements – and a big plus: NO RUST OR CORROSION. If your plant has poor water quality, the extra investment in stainless steel pays off fast in lower maintenance and maximum flow volumes at all times. With platen-mounted manifolds, you can put them into storage with no concern about rust.



# Steel Manifolds

## Painted and Stainless-SINGLE

### Features

- Painted manifolds are manufactured from heavy-gauge mild steel
- Threaded couplings are welded in place
- Pre-drilled mounting brackets for easy mounting
- Pressure rated to 120 PSI
- Temperature rated to 3000 F

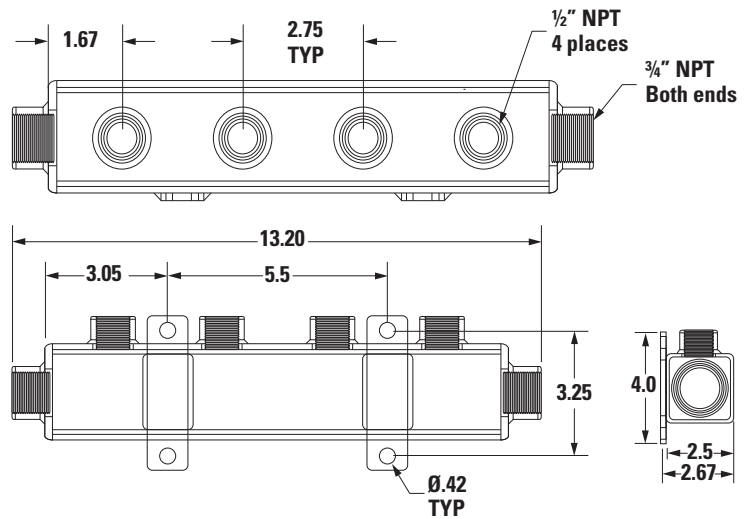
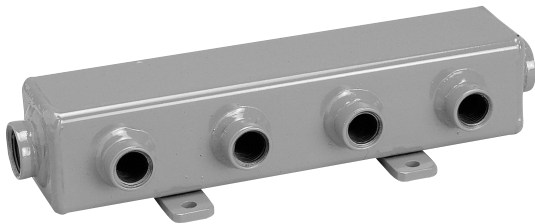

Steel Type	Inlets		Outlets		Dimensions			Part Number
	NPT	Qty.	NPT	Qty.	L	W	H	
Painted	3/4"	2	1/2"	4	12 3/4"	2 1/2"	2 1/2"	CWM4
Stainless	3/4"	2	1/2"	4	12 3/4"	2 1/2"	2 1/2"	CWM4CR



### PAINTED & STAINLESS STEEL MANIFOLDS

Steel Type	Inlets		Outlets		Dimensions			Part Number
	NPT	Qty.	NPT	Qty.	L	W	H	
Painted	1 1/4"	2	3/4"	8	24 1/4"	2 1/2"	2 1/2"	CWM8A
Stainless	1 1/4"	2	3/4"	8	24 1/4"	2 1/2"	2 1/2"	CWM8ACR

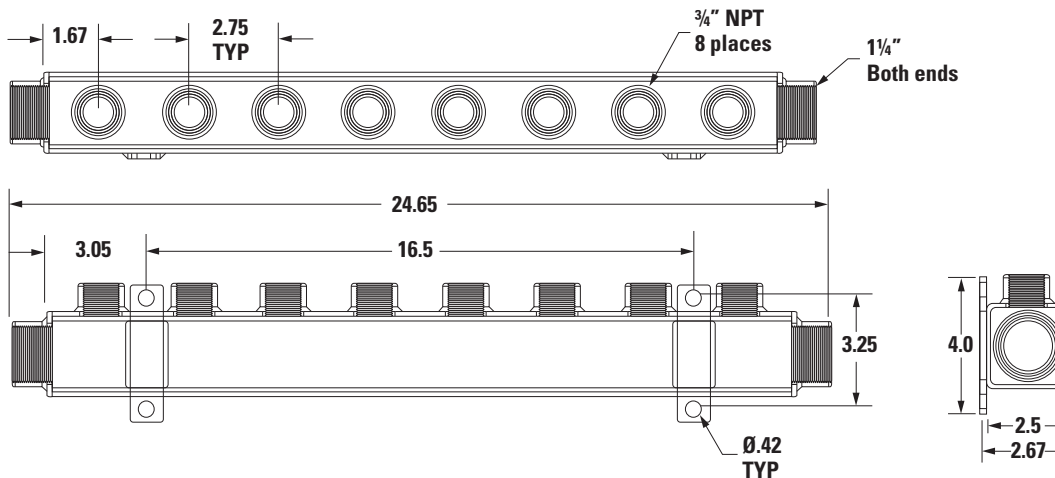

# Steel Manifolds



## Painted and Stainless-SINGLE

### Features

- Painted manifolds are manufactured from heavy-gauge mild steel
- Threaded couplings are welded in place
- Pre-drilled mounting brackets for easy mounting
- Pressure rated to 120 PSI
- Temperature rated to 3000 F

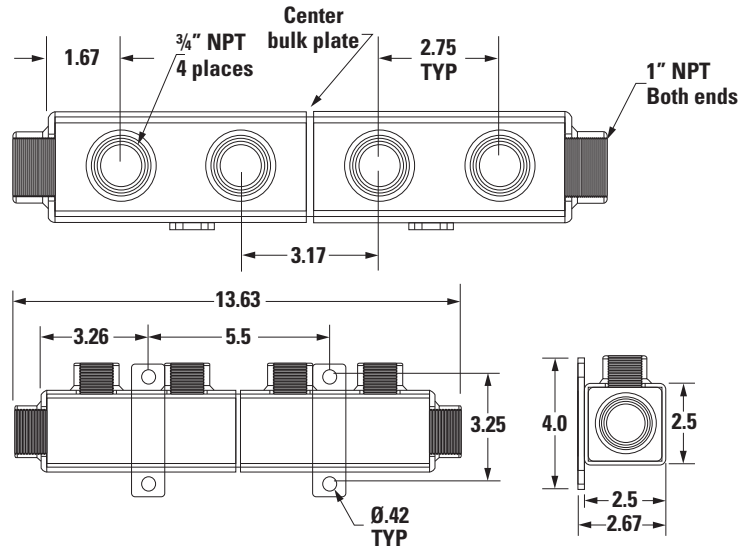

Steel Type	Inlets		Outlets		Dimensions			Part Number
	NPT	Qty.	NPT	Qty.	L	W	H	
Painted	1"	2	3/4"	4	13 1/2"	2 1/2"	2 1/2"	CWML22
Stainless	1"	2	3/4"	4	13 1/2"	2 1/2"	2 1/2"	CWML22CR

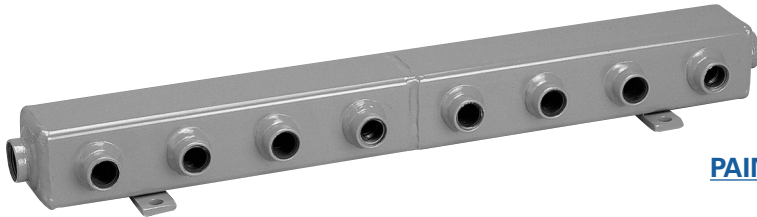

PAINTED & STAINLESS STEEL MANIFOLDS

Steel Type	Inlets		Outlets		Dimensions			Part Number
	NPT	Qty.	NPT	Qty.	L	W	H	
Painted	3/4"	2	1/2"	8	24"	2 1/2"	2 1/2"	CWM44
Stainless	3/4"	2	1/2"	8	24"	2 1/2"	2 1/2"	CWM44CR

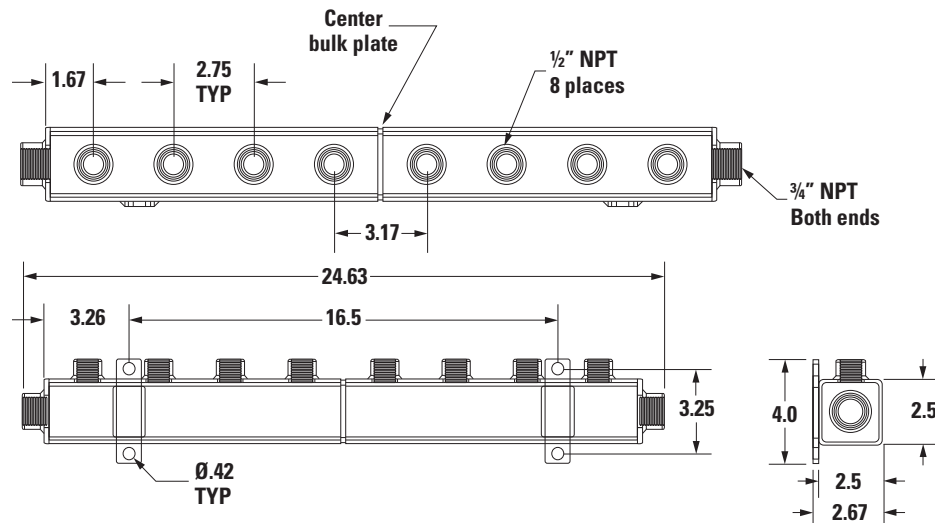



# Steel Manifolds

## Painted and Stainless-STACKED

### Features

- Painted manifolds are manufactured from heavy-gauge mild steel
- Threaded couplings are welded in place
- Pre-drilled mounting brackets for easy mounting
- Pressure rated to 120 PSI
- Temperature rated to 3000 F

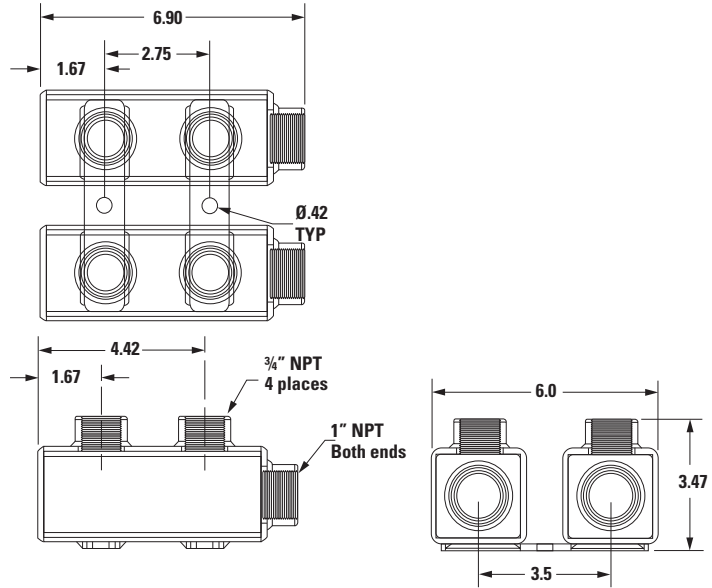

Steel Type	Inlets		Outlets		Dimensions			Part Number
	NPT	Qty.	NPT	Qty.	L	W	H	
Painted	1"	2	3/4"	4	7"	6"	2 1/2"	CWML2S2
Stainless	1"	2	3/4"	4	7"	6"	2 1/2"	CWML2S2CR

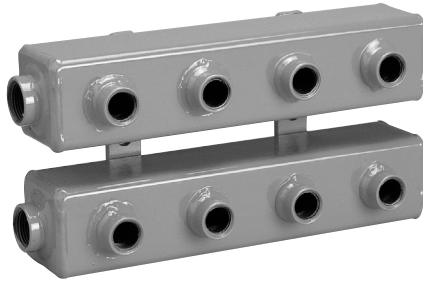

### PAINTED & STAINLESS STEEL MANIFOLDS

Steel Type	Inlets		Outlets		Dimensions			Part Number
	NPT	Qty.	NPT	Qty.	L	W	H	
Painted	3/4"	2	1/2"	8	12 1/4"	6"	2 1/2"	CWM4S4
Stainless	3/4"	2	1/2"	8	12 1/4"	6"	2 1/2"	CWM4S4CR

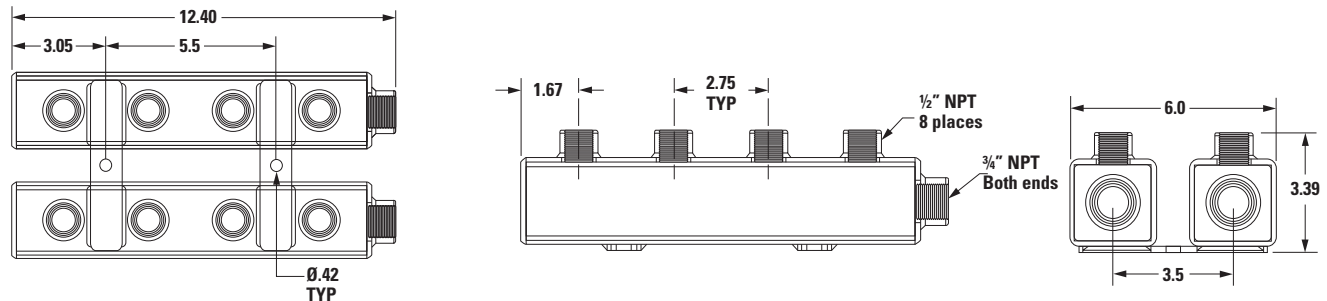



# Steel Manifolds



## Painted and Stainless-STACKED

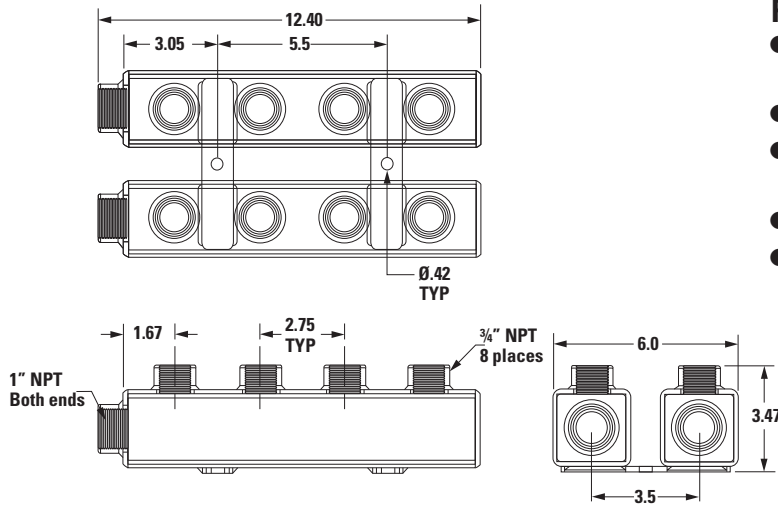

### Features

- Painted manifolds are manufactured from heavy-gauge mild steel
- Threaded couplings are welded in place
- Pre-drilled mounting brackets for easy mounting
- Pressure rated to 120 PSI
- Temperature rated to 300°F



Steel Type	Inlets		Outlets		Dimensions			Part Number
	NPT	Qty.	NPT	Qty.	L	W	H	
Painted	1"	2	3/4"	8	12 1/2"	6"	2 1/2"	CWML4S4
Stainless	1"	2	3/4"	8	12 1/2"	6"	2 1/2"	CWML4S4CR



### PAINTED & STAINLESS STEEL MANIFOLDS

Steel Type	Inlets		Outlets		Dimensions			Part Number
	NPT	Qty.	NPT	Qty.	L	W	H	
Painted	1 1/4"	2	3/4"	16	23 1/2"	6"	2 1/2"	CWM8S8A
Stainless	1 1/4"	2	3/4"	16	23 1/2"	6"	2 1/2"	CWM8S8ACR

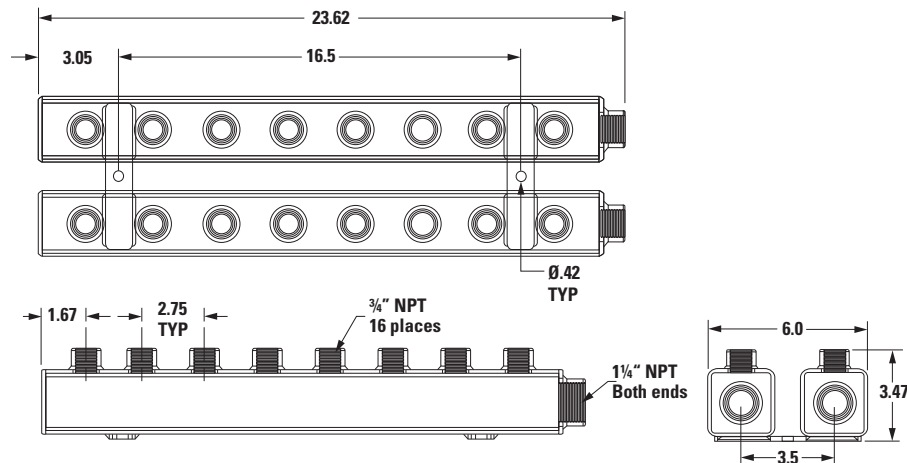



# Bronze Valved Manifolds

## Repair Kit

### Repair Kit

Includes ball, handle, nut, packing nut, stem, packing gland, thrust washer, 2 ball seats and adaptor.

**Part Number B6000Z76**



[BRONZE VALVED MANIFOLD REPAIR KIT](#)

# PTFE Thread Sealing Tape



## PTFE Tape Thread Sealants

- Permanent non-flammable seal
- Remains plastic permanently
- Operation temps -450°F to +500°F
- For water connections, hydraulics, air, gas, & petroleum
- The finest quality tape available
- NEVER use thinner, cheaper substitutes

### PTFE THREAD SEALING TAPE



Part Number	Length	Thickness	Width
TT100	260" (21.6')	0.0035	1/2"
TT200	520" (43.3')	0.0035	1/2"
TT300	520" (43.3')	0.0035	3/4"

## Thread Sealant

- Resists corrosion, leakage and loosening from vibration and moisture
- Anaerobic sealant chemically cures in the absence of air
- Use from -65°F To +350°F
- Allows final adjustments up to 24 hours after application
- Use for hydraulics, pneumatics, process piping or steam
- Locks and seals threaded fittings
- Easy disassembly without damage to threads
- Won't shrink away from fitting



Part Number	Container Size
49485	6 ml Tube
49486	50 ml Tube
49495	16 Oz Brush-Top

### THREAD SEALANT

## RTV Silicone

### RTV Silicone Adhesive Sealant

- Bonds most plastics many assembly uses
- Cures at room temperature to a tough, flexible rubber
- Resists shrinkage
- Perfect for caulking, sealing, waterproofing & bonding
- Bonds & seals terminals, connectors, mounting fixtures, mechanical gaskets, glass, metal, masonry, plastic, tile, rubber, wood & fabric
- Very attractive prices!



Operational Temp.(RTV Silicone): -60°F to +450°F Max Temp.(Silicone Gasket Makers): 650°F

Part Number	Container Size**	Color
49204	3 Oz Tube	Clear
49294	11 Oz Cartridge	Clear*
<b>Silicone Gasket Makers</b>		
49202	3 Oz Tube	Red
49292	11 Oz Cartridge	Red

### RTV SILICONE

\*Available in Marine Grade & Mildew Resistant \*\* Available in Larger Sizes!





# T-Handle Ball Valves

- ¼ turn on/off
- Fits close for tight installations
- Bottom loaded stem, blowout proof design
- Large port design/rated to 400 PSI W.O.G.
- PTFE stem packing & seats, viton seals
- Excellent flow compared to other valves in this class
- Forged brass body, chrome-plated ball



ISO 9002  
Registered Manufacturer

## T-HANDLE BALL VALVE

Part Number	NPT Thread
BBV2MFT	1/8"
BBV4MFT	1/4"
BBV6MFT	3/8"
BBV8MFT	1/2"

T-Handle is 1 5/8" wide for 1/8" & 1/4"; 2 1/2" for 3/8" & 1/2".

# Brass Gate Valves

- Heavy-duty die cast brass
- Screwed bonnet, non-rising stem, solid wedge disc and integral seats
- Recommended for non-stem use
- Asbestos-free graphite packing
- Pressure rating: 200 W.O.G. non-shock
- Very economical

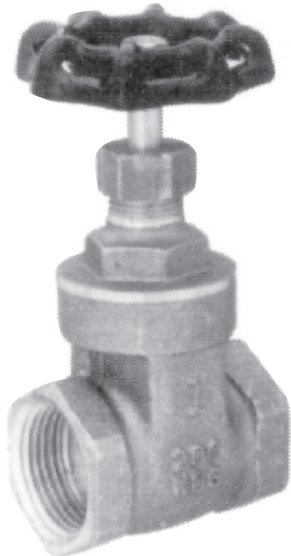
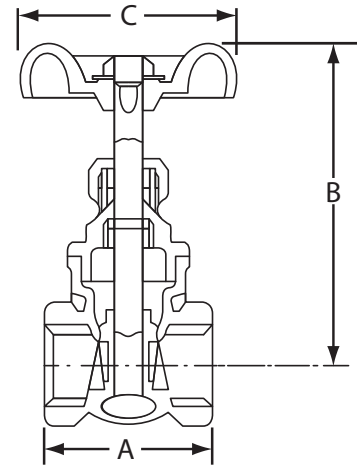

## CONTACT US

Part Number	Valve Size	A	B	C
BGV8	1/2"	1.54	2.72	2.13
BGV12	3/4"	1.73	2.92	2.13
BGV16	1"	1.85	3.31	2.13
BGV20	1 1/4"	2.09	3.86	2.40
BGV24	1 1/2"	2.25	4.57	2.96
BGV32	2"	2.4	4.93	2.96
	Available to 4"			

# Forged Brass Ball Valves



## Female x Female

- Extra heavy-duty bottom-loaded stem with a PTFE thrust washer and Viton O-ring
- PTFE seats, thrust washer and stem packing
- Self-cleaning, chromium-plated brass ball for maximum durability

Pressure Rating	
400 W.O.G. NON-SHOCK 125 W.S.P.	

Part Number	Ref. No.	Thd. Size	Rating	A	B	C	D
BBV2	-	1/8"	5.0	1.58	1.38	.31	1.71
BBV4*	BBV25	1/4"	10.8	1.58	1.96	.36	3.77
BBV6*	BBV37	3/8"	10.8	1.66	1.96	.48	3.77
BBV8*	BBV50	1/2"	21.6	2.08	2.41	.59	3.77
BBV12	BBV75	3/4"	14.2	2.05	2	.59	3.07
BBV16	BBV100	1"	28.6	2.62	2.58	.79	3.78
BBV20	BBV125	1 1/4"	56.4	2.9	2.93	.98	3.78
BBV24	BBV150	1 1/2"	114.0	3.28	3.25	1.26	3.78
BBV32	-	2"	162.9	3.81	4.13	1.58	3.78
BBV40	-	2 1/2"	200.0	4.48	5.1	2	7.88
BBV48	-	3"	380.0	5.33	6	2.5	7.88
BBV64	-	4"	550.0	6.86	7	2.96	7.88

\*BBV4, BBV6 and BBV8 full port; all others regular port.  
 Other sizes available in full port; call for stock status and pricing.  
 CV Rating is the gallons of water per minute passed thru the valve with a 1 PSI pressure drop.

### MATERIAL SPECIFICATIONS

Handle Nut .. Coated steel  
 Handle..... Coated steel  
 Stem Packing... Carbolon  
 Thrust Washer..... PTFE  
 Stem.....Brass  
 Ball Chrome-plated brass  
 Seats ..... PTFE  
 Body.....Forged brass  
 End AdapterForged brass

### FORGED BRASS BALL VALVES FXF

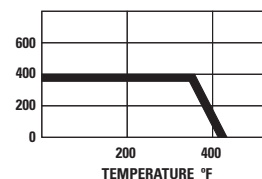

# Forged Brass Ball Valves



- Super-port BBV-MF is a full port, 2-piece ball valve with features only found on more expensive valves
- Extra heavy-duty, bottom-loaded stem with a PTFE thrust washer and Viton O-ring
- PTFE seats, thrust washer and stem packing
- Self cleaning, chromium-plated brass ball for maximum durability

### FORGED BRASS BALL VALVES MXF

Pressure Rating	
1/8" - 1/4"	400 lbs. W.O.G. Non-shock
3/8" - 3/4"	600 lbs. W.O.G. Non-shock
1"	500 lbs. W.O.G. Non-shock

All sizes rated at 150 W.S.P.

Part Number	Ref. No.	Thd. Size	(Mix-N-Match) Rating	A	B	C	D
BBV2MF	-	1/8"	7.2	1.8	1.41	.29	1.72
BBV4MF	BBV25M	1/4"	7.7	1.8	1.41	.32	1.65
BBV6MF	BBV37M	3/8"	10.8	2.15	1.7	.39	3.06
BBV8MF	BBV50M	1/2"	16.7	2.5	1.86	.50	3.06
BBV12MF	BBV75M	3/4"	30.3	2.9	2.5	.69	3.81
BBV16MF	BBV100M	1"	59.5	3.33	2.78	.89	3.81

CV Rating is the gallons of water per minute passed thru the valve with a 1 PSI pressure drop.

## Male x Female

### MATERIAL SPECIFICATIONS

Handle Nut .. Coated steel  
 Handle..... Coated steel  
 Packing Nut .....Brass  
 Stem Packing... Carbolon  
 Thrust Washer..... PTFE  
 Stem.....Brass  
 Ball Chrome-plated brass  
 Seats ..... PTFE  
 Body.....Forged brass  
 End AdapterForged brass

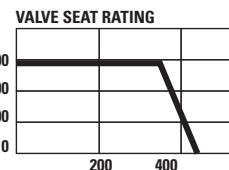
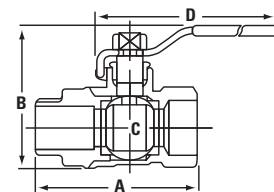





# Hi-Pressure Ball Valve

- Carbon steel construction with zinc dichromate plating
- Unrestricted bore up to 1" size
- Maximum working pressure of up to 7250 PSI
- POM ball seats & Buna seal standard
- Optional seal materials available for extreme temperature applications & fluid compatibility

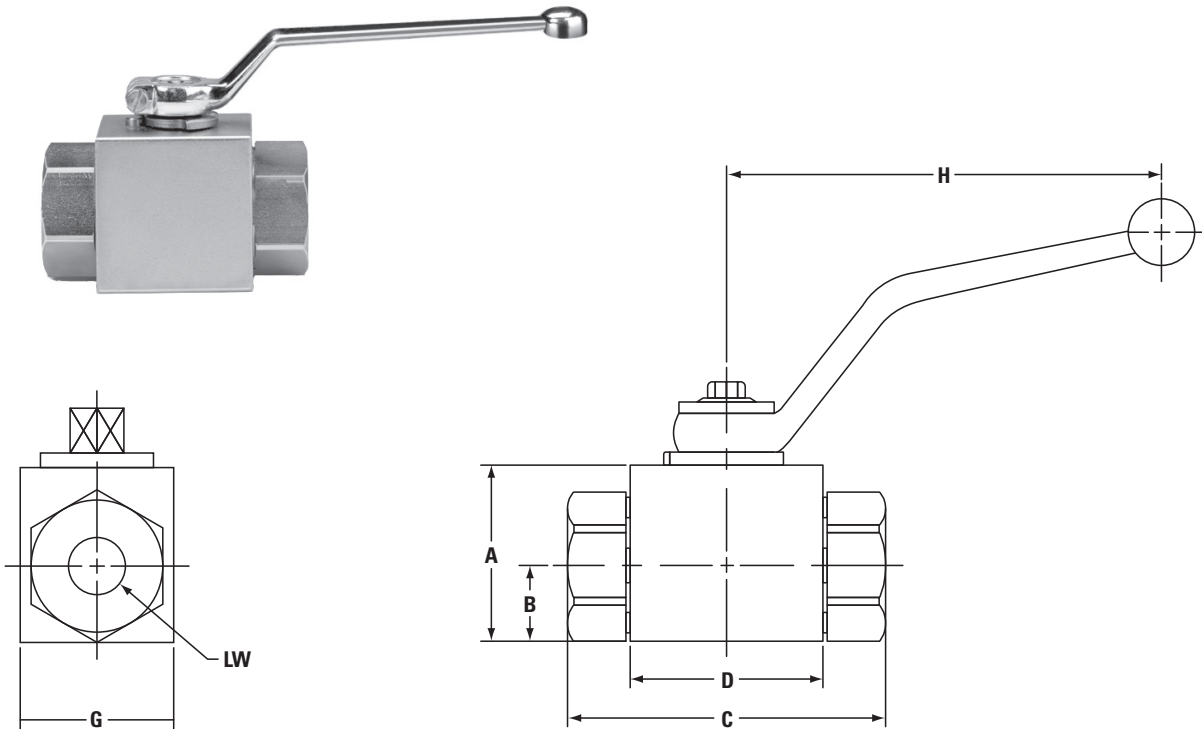

## CONTACT US

	Series		PSI (max)	Bore	A			G			H	Weight [lbs.]	
	NPT	SAE			Carbon	Stainless	B	C	D	Carbon			Stainless
Full Bore	AE2N18	N/A	7250	.16	1.38	C/F	0.55	2.80	1.65	1.18	C/F	4.33	1.1
	AE2N14	AE2S4	7250	.24	1.38	1.38	0.55	2.80	1.65	1.18	1.38	4.33	1.1
	AE2N38	AE2S6	7250	.39	1.57	1.57	0.67	2.87	1.73	1.38	1.57	4.33	1.4
	AE2N12	AE2S8	7250	.51	1.69	1.77	0.71	3.27	1.89	1.46	1.77	4.33	1.7
	AE2N34	AE2S12	5800	.79	2.17	2.17	0.91	3.74	2.44	1.77	2.17	7.09	3.1
	AE2N1	AE2S16	5075	.98	2.56	2.56	1.14	4.45	2.60	2.17	2.56	7.09	4.7
Reduced Bore	AE2N1-14R	AE2S20R	5075	.98	2.56	2.56	1.14	4.76	2.60	2.17	2.56	7.09	5.0
	AE2N1-12R	AE2S24R	5075	.98	2.56	2.56	1.14	4.88	2.60	2.17	2.56	7.09	5.2

# Hi-Pressure Ball Valve



## Model Code Breakdown

AE2 N½ \_ 1 1 D B

Valve Series . \_\_\_\_\_

Connection Type/Size . \_\_\_\_\_

N	NPTE Pipe Thread
S	SAE Straight Thread

Bore Restriction . \_\_\_\_\_

blank	Unrestricted Bore
R	Restricted Bore

Body & Adapter Material . \_\_\_\_\_

1	Carbon Steel
2	316 Stainless Steel

. Adapter & Stem Seals

B	Buna-Standard
V	Viton

. Ball Seats

D	POM-Standard
T	PTFE

. Ball & Stem Material

1	Carbon Steel
2	316 Stainless Steel

## MAXIMUM & MINIMUM WORKING TEMPERATURES FOR SEAL MATERIALS

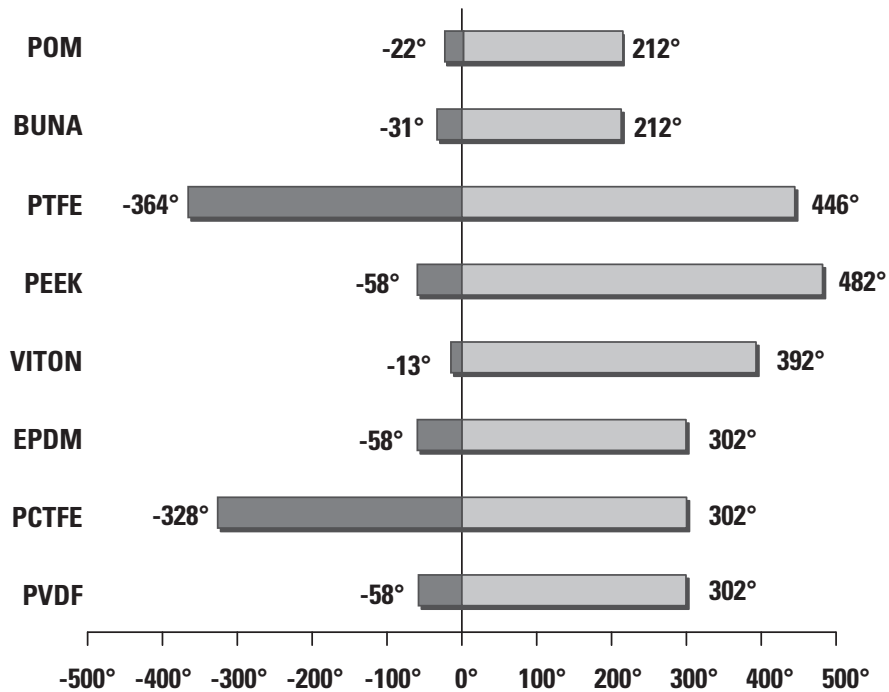



# High Flow Couplers

## ST SERIES

### HIGH FLOW COUPLERS/NIPPLES

1. The smooth, open bore with no valving in either half offers minimal pressure drop, allowing easy cleaning in applications where the same lines are used for more than one media.

2. ST couplers and nipples are machined from solid bar stock, providing a quality coupling that is durable. ST couplers are available in brass as standard product materials.

3. ST nipples are available in brass. The ball locking grooves of the brass

ST nipples are case hardened for resistance to brinelling where high cycle rates and pressure surges are encountered.

4. The ST is an "industrial interchange" coupling since it is dimensionally and functionally interchangeable with similar couplings manufactured by other major manufacturers.

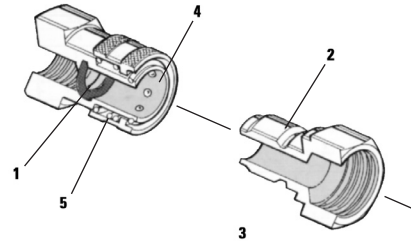

#### Female Pipe Coupler

Body Size	Thd Size Fem. NPT	Material	
		Brass Part Number	Stainless Steel Part Number
1/8"	1/8-27	BST1	SST1
1/4"	1/4-18	BST2	SST2
3/8"	3/8-18	BST3	SST3
1/2"	1/2-14	BST4	SST4
3/4"	3/4-14	BST6	SST6
1"	1-1 1/2	BST8	SST8
1 1/4"	1 1/4-11	BST10	
1 1/2"	1 1/2-11	BST12	

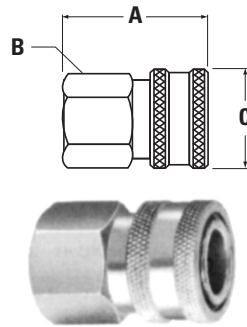

See table below for dimensions.

#### Male Pipe Coupler

Body Size	Thd Size Fem. NPT	Material	
		Brass Part Number	Stainless Steel Part Number
1/8"	1/8-27	BST1M	SST1M
1/4"	1/4-18	BST2M	SST2M
3/8"	3/8-18	BST3M	SST3M
1/2"	1/2-14	BST4M	SST4M
3/4"	3/4-14	BST6M	SST6M
1"	1-11	BST8M	SST8M

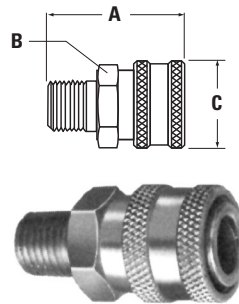

See table below for dimensions.

#### Dimensions

	Female Pipe			Male Pipe		
	A	B	C	A	B	C
1/8"	1.00	.56	.69	1.06	.56	.69
1/4"	1.47	.81	.94	1.69	.81	.81
3/8"	1.59	1.00	1.16	1.75	1.00	1.16
1/2"	1.91	1.13	1.30	1.94	1.13	1.30
3/4"	2.05	1.44	1.66	2.17	1.44	1.66
1"	2.31	1.75	2.02	2.53	1.75	2.02
1 1/4"	2.44	2.00	2.51			
1 1/2"	2.88	2.50	3.00			

#### O-Rings for ST Couplers

Part Number	Coupler Size
ST10R	1/8"
ST20R	1/4"
ST30R	3/8"
ST40R	1/2"
ST60R	3/4"
ST80R	1"
ST100R	1 1/4"
ST120R	1 1/2"

# High Flow Nipples



## ST SERIES

### HIGH FLOW COUPLERS/NIPPLES

Pressure/Temp Ratings			
Size	Brass	Steel	Stainless
1/8"	2500	2600	4200
1/4"	5200	5500	6700
3/8"	2700	3500	5500
1/2"	2200	2700	3000
3/4"	1700	2700	3000
1"	1200	2000	1700
1 1/4"	1700	Ratings Are	
1 1/2"	1400	In PSI	

-40° to +250° F - Temp Range

- Non-valved for high flow
- Very low pressure drop
- Standard seal material is Buna-N
  - Other material available upon request
- Nipples & couplers interchangeable with similar types from other manufacturers
- Couplers and nipples are available in brass
- High quality, low prices!

Female Pipe Nipples		Brass	Steel	Stainless Steel
Body Size	Thd Size Fem. NPT	Part Number	Part Number	Part Number
1/8"	1/8-27	BSTN1	STN1	SSTN1
1/4"	1/4-18	BSTN2	STN2	SSTN2
3/8"	3/8-18	BSTN3	STN3	SSTN3
1/2"	1/2-14	BSTN4	STN4	SSTN4
3/4"	3/4-14	BSTN6	STN6	SSTN6
1"	1-11	BSTN8	STN8	SSTN8
1 1/4"	1 1/4-11 1/2	BSTN10		
1 1/2"	1 1/2-11 1/2	BSTN12		

See table below for dimensions.

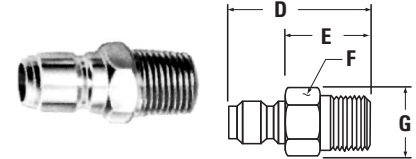
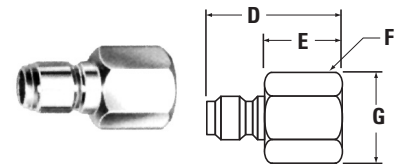

Male Pipe Nipples		Brass	Steel	Stainless Steel
Body Size	Thd Size Fem. NPT	Part Number	Part Number	Part Number
1/8"	1/8-27	BSTN1M	STN1M	SSTN1M
1/4"	1/4-18	BSTN2M	STN2M	SSTN2M
3/8"	3/8-18	BSTN3M	STN3M	SSTN3M
1/2"	1/2-14	BSTN4M	STN4M	SSTN4M
3/4"	3/4-14	BSTN6M	STN6M	SSTN6M
1"	1-11	BSTN8M	STN8M	SSTN8M

See table below for dimensions.

### Dimensions

	Female Pipe				Male Pipe			
	D	E	F	G	D	E	F	G
1/8"	.98	.57	.56	.65	1.04	.63	.44	.51
1/4"	1.39	.67	.75	.87	1.53	.81	.56	.65
3/8"	2.04	.96	1.38	1.59	1.69	.86	.69	.79
1/2"	1.85	.95	1.13	1.30	1.94	1.01	.88	1.01
3/4"	2.04	.96	1.38	1.59	2.19	1.11	1.06	1.23
1"	2.16	1.00	1.63	1.88	2.51	1.34	1.38	1.59
1 1/4"	2.38	1.11	2.00	2.31				
1 1/2"	2.81	1.17	2.38	2.74				



# Air Couplers

For Male Fittings  
Refer to Next Page!!

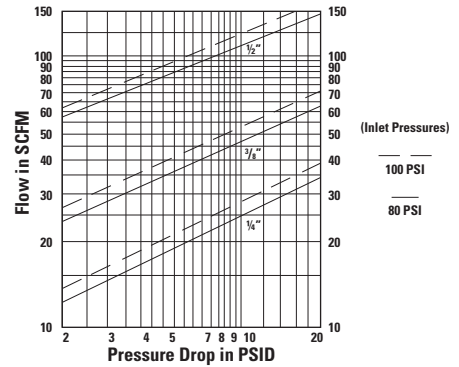

- Solid barstock construction
- High flow/low pressure drop
- 20 series
- Low, low price!
- Off-the-shelf delivery!

## AIR COUPLERS

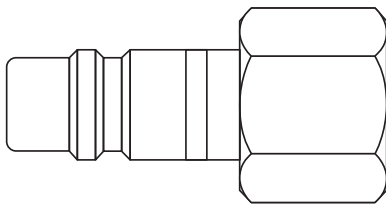

1/2" BODY SIZE

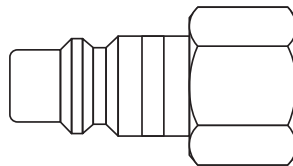

3/8" BODY SIZE

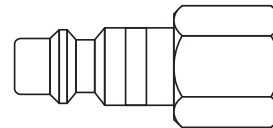

1/4" BODY SIZE

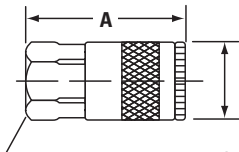
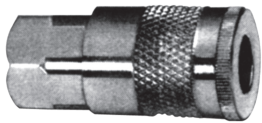

Valved Air Coupler

### Female Coupler

Part Number	Body Size	Body Material	Thread Size	Overall A	Hex B	Dia. C
B204F2	1/4	Brass	1/8	1.83	.75	.88
B204F4	1/4	Brass	1/4	1.83	.75	.88
B204F6	1/4	Brass	3/8	1.95	.81	.94
206F4	3/8	Steel	1/4	2.22	.88	1.06
206F6	3/8	Steel	3/8	2.28	.88	1.06
206F8	3/8	Steel	1/2	2.55	1.00	1.16
0208F6	1/2	Steel	3/8	2.74	1.00	1.19
208F8	1/2	Steel	1/2	2.96	1.00	1.19
208F12	1/2	Steel	3/4	3.19	.25	1.44

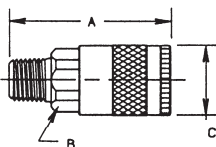
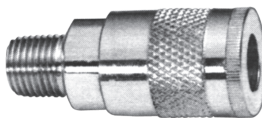

Valved Air Coupler

### Male Coupler

Part Number	Body Size	Body Material	Thread Size	Overall A	Hex B	Dia. C
B204M2	1/4	Brass	1/8	1.89	.75	.88
B204M4	1/4	Brass	1/4	2.05	.75	.88
B204M6	1/4	Brass	3/8	2.08	.75	.88
206M4	3/8	Steel	1/4	2.36	.88	1.06
206M6	3/8	Steel	3/8	2.39	.88	1.06
206M8	3/8	Steel	1/2	2.55	.88	1.06
208M6	1/2	Steel	3/8	2.93	1.00	1.19
208M8	1/2	Steel	1/2	3.08	1.00	1.19
208M12	1/2	Steel	3/4	3.21	1.13	1.19



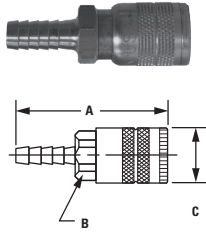

## Hose Barb Coupler

Part Number	Body Size	Body Material	Hose I. D.	Overall A	Hex B	Dia. C
B204HB4	1/4	Brass	1/4	2.49	.75	.88
B204HB5	1/4	Brass	5/16	2.49	.75	.88
B204HB6	1/4	Brass	3/8	2.49	.75	.88
206HB6	3/8	Steel	3/8	2.86	.88	1.06
206HB8	3/8	Steel	1/2	3.08	.88	1.06
208HB6	1/2	Steel	3/8	3.37	1.00	1.19
208HB8	1/2	Steel	1/2	3.62	1.00	1.19
208HB12	1/2	Steel	3/4	3.96	1.00	1.19

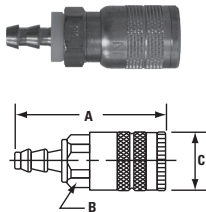

## Push-Lok® Coupler

Part Number	Body Size	Body Material	Hose I. D.	Overall A	Hex. B	Dia. C
B204PL4	1/4	Brass	1/4	2.49	.75	.88
B204PL6	1/4	Brass	3/8	2.49	.75	.88
206PL6	3/8	Steel	3/8	2.49	.75	.88
208PL6	1/2	Steel	3/8	2.86	.88	1.06
208PL8	1/2	Steel	1/2	3.08	.88	1.06

# Industrial Interchange Nipples

These fit all the couplers pictured above and on previous page. They also will work with any MIL-C4109 Couplers. We provide high-quality parts at everyday low prices! Same day shipping on most orders.

## INDUSTRIAL INTERCHANGE NIPPLES

### Female Pipe

Part Number	Coupler Size	Female NPT
N204F2	1/4	1/8
N204F4	1/4	1/4
N204F6	1/4	3/8
N206F4	3/8	1/4
N206F6	3/8	3/8
N206F8	3/8	1/2
N208F6	1/2	3/8
N208F8	1/2	1/2
N208F12	1/2	3/4

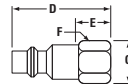

### Male Pipe

Part Number	Coupler Size	Male NPT
N204M2	1/4	1/8
N204M4	1/4	1/4
N204M6	1/4	3/8
N206M4	3/8	1/4
N206M6	3/8	3/8
N206M8	3/8	1/2
N208M6	1/2	3/8
N208M8	1/2	1/2
N208M12	1/2	3/4

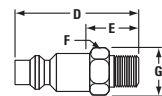

### Hose Barb Nipple

Part Number	Coupler Size	Hose I. D.
N204HB4	1/4	1/4
N204HB5	1/4	5/16
N204HB6	1/4	3/8
N206HB6	3/8	3/8
N206HB8	3/8	1/2
N208HB6	1/2	3/8
N208HB8	1/2	1/2
N208HB12	1/2	3/4

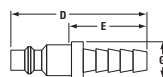

### Push-Lok® Nipple

Part Number	Coupler Size	Hose I. D.
N204PL4	1/4	1/4
N204PL6	1/4	3/8
N206PL4	3/8	1/4
N206PL6	3/8	3/8
N206PL8	3/8	1/2
N208PL6	1/2	3/8
N208PL8	1/2	1/2

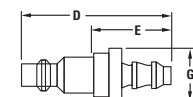



# Hydraulic Couplers

## HYDRAULIC COUPLERS

### Materials

Steel Body - Body, sleeve & valve are zinc-plated steel. Retaining rings, springs and locking balls are stainless. Buna-N or Viton o-rings are standard.

### Female Body - 990

Hydraulic Couplers are double-side, shutoff poppet type in steel, stainless steel and brass. Available with Buna-N or Viton seals. This series is directly interchangeable with Parker 60 Series, Hansen HK Series, Aeroquip FD-45 Series and others.

Hardened nipples & sleeves and solid barstock construction assure a long service life by providing maximum resistance to hydraulic shock and abuse common in industrial applications.

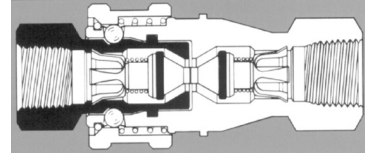

### Male Tip - 991

303 Stainless Steel - Body, sleeves, valves, retaining rings, springs and locking balls

are stainless. Buna-N or Viton o-rings are standard.

Brass Body - Body, sleeve and valves are brass. Retaining rings, springs and locking balls are stainless. Buna-N or Viton o-rings are standard.



### Female Body Half - Steel

### Male Body Half - Steel

Part Number		Body Material	Thd Size NPT	Part Number		Tip Material	Thd Size NPT
Buna Seals	Viton Seals			Buna Seals	Viton Seals		
990-2	990-2V	Steel	1/4"	991-2	991-2V	Steel	1/4"
990-3	990-3V	Steel	3/8"	991-3	991-3V	Steel	3/8"
990-4	990-4V	Steel	1/2"	991-4	991-4V	Steel	1/2"
990-6	990-6V	Steel	3/4"	991-6	991-6V	Steel	3/4"
990-8	990-8V	Steel	1"	991-8	991-8V	Steel	1"

### Female Body Half - Brass

### Male Body Half - Brass

Part Number		Body Material	Thd Size NPT	Part Number		Tip Material	Thd Size NPT
Buna Seals	Viton Seals			Buna Seals	Viton Seals		
990-2B	990-2BV	Brass	1/4"	991-2B	991-2BV	Brass	1/4"
990-3B	990-3BV	Brass	3/8"	991-3B	991-3BV	Brass	3/8"
990-4B	990-4BV	Brass	1/2"	991-4B	991-4BV	Brass	1/2"
990-6B	990-6BV	Brass	3/4"	991-6B	991-6BV	Brass	3/4"
990-8B	990-8BV	Brass	1"	991-8B	991-8BV	Brass	1"

### Female Body Half - Stainless Steel

### Male Body Half - Stainless Steel

Part Number		Body Material	Thd Size NPT	Part Number		Tip Material	Thd Size NPT
Buna Seals	Viton Seals			Buna Seals	Viton Seals		
990-2S	990-2SV	Stainless	1/4"	991-2S	991-2SV	Stainless	1/4"
990-3S	990-3SV	Stainless	3/8"	991-3S	991-3SV	Stainless	3/8"
990-4S	990-4SV	Stainless	1/2"	991-4S	991-4SV	Stainless	1/2"
990-6S	990-6SV	Stainless	3/4"	991-6S	991-6SV	Stainless	3/4"
990-8S	990-8SV	Stainless	1"	991-8S	991-8SV	Stainless	1"

# Flat Face Couplers



- No-spill coupling design, low air inclusion; 2,500 PSI operating pressure
- Sleeve lock prevents accidental disconnection
- Dust seal is designed into coupling to prevent dirt inclusion into hydraulic system
- Low cost, high pressure

## FLAT FACE COUPLERS

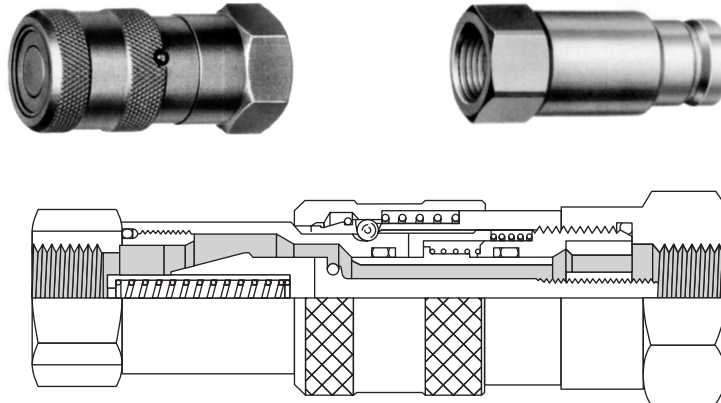

### Female Couplers

Part Number			
Buna Seals	Viton Seals	Metal	Thread Size NPT
FF990-3	FF990-3V	Steel	3/8"
FF990-4	FF990-4V	Steel	1/2"

### Male Couplers

Part Number			
Buna Seals	Viton Seals	Metal	Thread Size NPT
FF991-3	FF991-3V	Steel	3/8"
FF991-4	FF991-4V	Steel	1/2"

E



# Water Couplers

## Flow-Thru

DME plugs used with DME Flow-Thru Type Sockets and DME Automatic Shut-off Type Sockets are designed for water, air or oil lines in plastics molds and die cast dies. They feature a combination brass and stainless steel leakproof construction; have a maximum rated capacity of 200 PSI; and withstand temperatures up to 400°F, with supplied Viton seals. DME Sockets can be used interchangeably with the same plugs already in your mold or die. Comparable sizes of both socket types have the same O.D., permitting interchangeability even when the plugs are flush mounted.

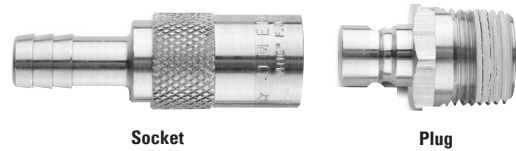

### FLOW THRU WATER COUPLERS

#### Sockets(Flow-Thru Type)

DME Flow-Thru Type Sockets have a large thru hole to provide unrestricted flow. These quick-connection couplers are available with either straight, 45° or 90° hose stems, or standard female or male NPT threads.

DME Flow-Thru and Automatic Shut-Off Type Sockets have the same O.D., permitting complete interchangeability with plugs installed in your mold or die.

DME Sockets can be used with either male, female or extension plugs.

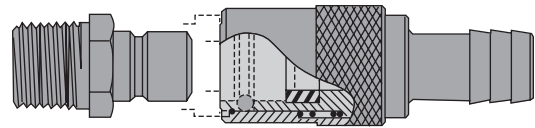

Description	Part Number	Nominal Passage	Hose I. D.	Fit Any Plug Number
 Straight Stem	NS204	1/4	1/4	NS251-252-253 (F) (FB)
	NS205	1/4	5/16	NS251-252-253 (F) (FB)
	NS206	1/4	3/8	NS251-252-253 (F) (FB)
	NS306	3/8	3/8	NS352-353-354 (F) (FB)
	NS308	3/8	1/2	NS352-353-354 (F) (FB)
	NS308HF*	7/16	1/2	NS352-353-354 (F) (FB)
	NS504	1/2	1/2	NS554 (F)
NS506	1/2	3/4	NS554 (F)	

Description	Part Number	Nominal Passage	Hose I. D.	Fit Any Plug Number
 45° Stem	NS224	1/4	1/4	NS251-252-253 (F) (FB)
	NS225	1/4	5/16	NS251-252-253 (F) (FB)
	NS226	1/4	3/8	NS251-252-253 (F) (FB)
	NS326	3/8	3/8	NS352-353-354 (F) (FB)
	NS328	3/8	1/2	NS352-353-354 (F) (FB)
	NS328HF*	7/16	1/2	NS352-353-354 (F) (FB)
	NS524	1/2	1/2	NS554 (F)
NS526	1/2	3/4	NS554 (F)	

Description	Part Number	Nominal Passage	Hose I. D.	Fit Any Plug Number
 90° Stem	NS214	1/4	1/4	NS251-252-253 (F) (FB)
	NS215	1/4	5/16	NS251-252-253 (F) (FB)
	NS216	1/4	3/8	NS251-252-253 (F) (FB)
	NS316	3/8	3/8	NS352-353-354 (F) (FB)
	NS318	3/8	1/2	NS352-353-354 (F) (FB)
	NS318HF*	7/16	1/2	NS352-353-354 (F) (FB)
	NS514	1/2	1/2	NS554 (F)
NS516	1/2	3/4	NS554 (F)	

Description	Part Number	Nominal Passage	Hose I. D.	Fit Any Plug Number
 Socket Only	NS200	1/4	1/8 NPT	NS251-252-253 (F) (FB)
	NS300	3/8	1/4 NPT	NS352-353-354 (F) (FB)
	NS300HF*	7/16	3/8 NPT	NS352-353-354 (F) (FB)
	NS500	1/2	1/2 NPT	NS554 (F)

\* Indicates High Flow

# Water Couplers

## SV Series

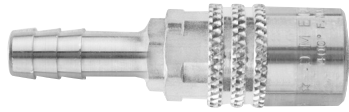

Socket



Plug

### SV-Series Connectors – NS

#### Two-Way Automatic Shut-Off Type

The DME line of SV-Series Connectors features a male plug and socket, each with an automatic shut-off stemmed valve. These connectors are designed for use with plastics molds and die cast dies in water, air or heat transfer oil lines. They feature a combination of brass and stainless steel in a leak-proof construction, have a maximum rated capacity of 200 PSI and will withstand temperatures up to 400°F with supplied Viton seals.

The SV-Series Male Plugs add the capability of automatic shut-off at the mold, thereby minimizing coolant loss.

DME SV-Series Sockets can be used interchangeably with the plugs already in your mold or die. However, the SV-Series Male Plugs can ONLY be used with the SV-Series Sockets. Comparable sizes of both types of sockets and plugs have the same O.D., permitting interchangeability even when the plugs are flush-mounted.

The SV-Series Male Plugs are now supplied with thread sealant. Eliminating the initial need for joint tape or compound, the sealant will withstand temperatures up to 400°F and pressures up to 200 PSI.

### SV-Series Male Plugs

#### (Automatic Shut-Off Type with Stemmed Valve)

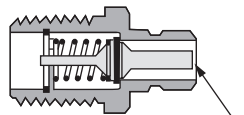

Stemmed Valve (SV)

The DME SV-Series Male Plugs feature an automatic shut-off stemmed valve. This plug design adds the capability of automatic shut-off at the mold. The plug's shut-off stemmed valve minimizes mold coolant loss, thereby decreasing cleanup time and the possibility of rust occurring on the mold surface. The SV-Series Male Plug can ONLY be used with the SV-Series Socket.

### SV-Series Sockets

#### (Automatic Shut-Off Type with Stemmed Valve)

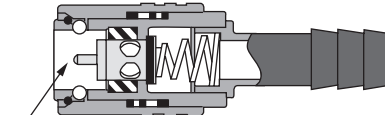

Stemmed Valve (SV)

The DME SV-Series Sockets feature an automatic shut-off stemmed valve that is designed to work with the SV-Series Male Plugs, as well as the standard male, female and extension plugs. The sockets open automatically when connected and shut off automatically when disconnected. The SV-Series Sockets are designed to keep flow restriction to a minimum and are available with either straight, 45° or 90° hose stems.



## Operating Combinations

### Two-Way Shut-Off\*

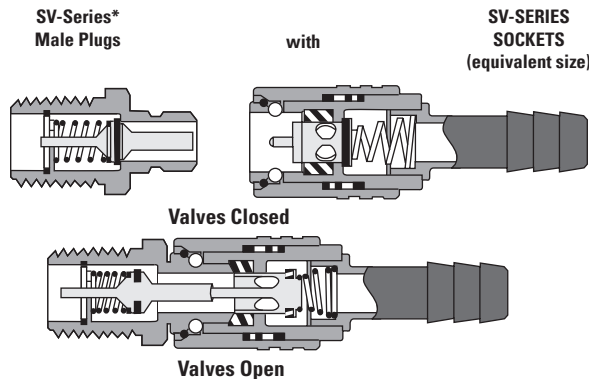

### One-Way Shut-Off

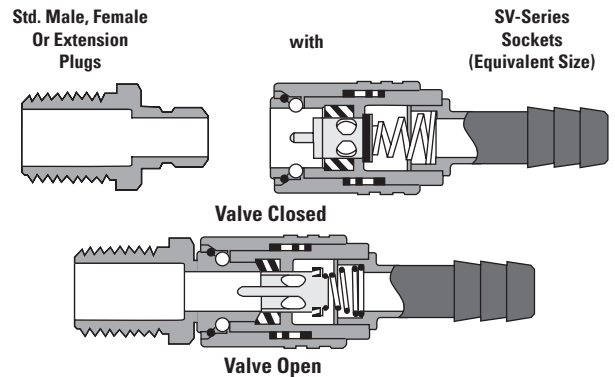

\*The SV-Series Male Plugs can only be used for two-way shut-offs and must be used with the SV-Series Sockets.





# Water Couplers

## Quick Release, Automatic One-Way Shutoff

DME plugs used with DME Flow-Thru Type Sockets and DME **Automatic**

Shutoff Type Sockets are designed for plastics molds and die cast dies in water, air or oil lines. They feature a combination brass and stainless steel leakproof construction; have a maximum rated capacity of 200 PSI; and withstand temperatures up to 400°F, with supplied Viton seals. DME Sockets can be used interchangeably with the same plugs already in your mold or die. Comparable sizes of both socket types have the same O.D., permitting interchangeability even when the plugs are flush mounted.



Socket

Plug

### Sockets(Automatic Shut-Off Type)

DME Automatic Shut-off Type Sockets open automatically when connected and shut off automatically when disconnected. Unlike most valve-type connectors, DME Sockets are designed to keep flow restriction to a minimum.

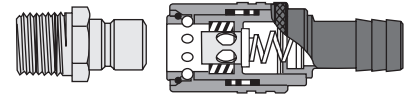

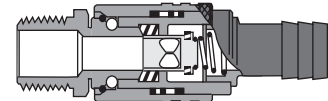

Value Closed



Value Open

Description	Part Number	Nominal Passage	Hose I. D.	Fit Any Plug Number
 Straight Stem	NS204V	1/4	1/4	NS251-252-253 (F) (FB)
	NS205V	1/4	5/16	NS251-252-253 (F) (FB)
	NS206V	1/4	3/8	NS251-252-253 (F) (FB)
	NS306V	3/8	3/8	NS352-353-354 (F) (FB)
	NS308V	3/8	1/2	NS352-353-354 (F) (FB)
	NS504V	1/2	1/2	NS554 (F)
	NS506V	1/2	3/4	NS554 (F)

Description	Part Number	Nominal Passage	Hose I. D.	Fit Any Plug Number
 45° Stem	NS224V	1/4	1/4	NS251-252-253 (F) (FB)
	NS225V	1/4	5/16	NS251-252-253 (F) (FB)
	NS226V	1/4	3/8	NS251-252-253 (F) (FB)
	NS326V	3/8	3/8	NS352-353-354 (F) (FB)
	NS328V	3/8	1/2	NS352-353-354 (F) (FB)
	NS524V	1/2	1/2	NS554 (F)
	NS526V	1/2	3/4	NS554 (F)

Description	Part Number	Nominal Passage	Hose I. D.	Fit Any Plug Number
 90° Stem	NS214V	1/4	1/4	NS251-252-253 (F) (FB)
	NS215V	1/4	5/16	NS251-252-253 (F) (FB)
	NS216V	1/4	3/8	NS251-252-253 (F) (FB)
	NS316V	3/8	3/8	NS352-353-354 (F) (FB)
	NS318V	3/8	1/2	NS352-353-354 (F) (FB)
	NS514V	1/2	1/2	NS554 (F)
	NS516V	1/2	3/4	NS554 (F)

Description	Part Number	Nominal Passage	Hose I. D.	Fit Any Plug Number
 Socket Only	NS200SV	1/4	1/8 NPT	NS251-252-253 (F) (FB)
	NS300SV	3/8	1/4 NPT	NS252-353-354 (F) (FB)
	NS500SV	1/2	1/2 NPT	NS554 (F)

[QUICK RELEASE WATER](#)

[COUPLERS](#)

# Water Couplers





## Quick Release, Automatic Two-Way Shutoff

[CONTACT US](#)

Description	Part Number	Nominal Passage	Hose I. D.	Fit Any Plug Number
	NS204SV	1/4	1/4	NS252SV
	NS205SV	1/4	5/16	NS253SV
	NS206SV	1/4	3/8	NS352SV
	NS306SV	3/8	3/8	NS353SV
	NS308SV	3/8	1/2	NS354SV

Description	Part Number	Nominal Passage	Hose I. D.	Fit Any Plug Number
	NS224SV	1/4	1/4	NS252SV
	NS225SV	1/4	5/16	NS253SV
	NS226SV	1/4	3/8	NS352SV
	NS326SV	3/8	3/8	NS353SV
	NS328SV	3/8	1/2	NS354SV

Description	Part Number	Nominal Passage	Hose I. D.	Fit Any Plug Number
	NS214SV	1/4	1/4	NS252SV
	NS215SV	1/4	5/16	NS253SV
	NS216SV	1/4	3/8	NS352SV
	NS316SV	3/8	3/8	NS353SV
	NS318SV	3/8	1/2	NS354SV

Description	Part Number	Nominal Passage	Hose I. D.	Fit Any Plug Number
	NS200SV	1/4	1/8 NPT	NS252SV
	NS300SV	3/8	1/4 NPT	NS253SV





# Water Couplers

## Push To Connect/Push To Lock, Flow-Thru Type

### With Clampless Hose Stems for use with Push-To-Connect/ Push-To-Lock Type Hose

- For use with push-to-connect/push-to-lock type hose only
- Saves setup time by eliminating the need for hose clamps
- Hose stem barbs mate with "Push-to-Lock" style rubber hose
- Popular sizes for interchangeability with existing and SV Sockets
- More compact and consistently sized than competitive sockets
- Leakproof brass and stainless steel construction
- Replaceable seals and valves for long service life
- Socket connector seals are Viton

Description	Part Number	Nominal Passage	Hose I. D.	Fit Any Plug Number
	NS204PL	1/4	1/4	NS252PL
	NS206PL	1/4	5/16	NS253PL
	NS306PL	1/4	3/8	NS352PL
	NS308PL	3/8	1/2	NS353PL NS354PL
	NS504PL	3/8	1/2	NS554 (F)
	NS506PL	7/16	1/2	NS554 (F)

[PUSH TO CONNECT WATER  
COUPLERS](#)

Description	Part Number	Nominal Passage	Hose I. D.	Fit Any Plug Number
	NS224PL	1/4	1/4	NS252PL
	NS226PL	1/4	3/8	NS253PL
	NS326PL	3/8	3/8	NS352PL
	NS328PL	3/8	1/2	NS353PL NS354PL
	NS524PL	1/2	1/2	NS554 (F)
	NS526PL	1/2	3/4	NS554 (F)

Description	Part Number	Nominal Passage	Hose I. D.	Fit Any Plug Number
	NS214PL	1/4	1/4	NS252PL
	NS216PL	1/4	3/8	NS253PL
	NS316PL	3/8	3/8	NS352PL
	NS318PL	3/8	1/2	NS353PL NS354PL
	NS514PL	1/2	1/2	NS554 (F)
	NS516PL	1/2	3/4	NS554 (F)

Note: Use "Push-to-Lock" type hose only. Connector Sockets are for use with water and water-based coolants only. Although Connector Sockets are suitable for temperatures to 400°F, observe the temperature ratings of your "push-to-lock" hose. Most "push-to-lock" hoses have a temperature rating of 175°F or less. Never exceed 200 PSI.

# Water Couplers



## Push To Connect/Push To Lock, Auto One-Way Shutoff

### With Clampless Hose Stems for use with Push-To-Connect/Push-To-Lock Type Hose

- For use with push-to-connect/push-to-lock type hose only
- Saves setup time by eliminating the need for hose clamps
- Hose stem barbs mate with "Push-to-Lock" style rubber hose
- Popular sizes for interchangeability with existing and SV sockets
- More compact and consistently sized than competitive sockets
- Leakproof brass and stainless steel construction
- Replaceable seals and valves for long service life
- Socket connector seals are Viton

### PUSH TO CONNECT WATER COUPLERS



Description	Part Number	Nominal Passage	Hose I. D.	Fit Any Plug Number
<b>Straight Stem</b>	NS204VPL	1/4	1/4	NS252
	NS206VPL	1/4	3/8	NS253
	NS306VPL	3/8	3/8	NS352
	NS308VPL	3/8	1/2	NS353 NS354
	NS504VPL	1/2	1/2	NS554 (F) (FB) 556 (FB)
	NS506VPL	1/2	3/4	NS554 (F) (FB) 556 (FB)

Description	Part Number	Nominal Passage	Hose I. D.	Fit Any Plug Number
<b>45° Stem</b>	NS224VPL	1/4	1/4	NS252
	NS226VPL	1/4	3/8	NS253
	NS326VPL	3/8	3/8	NS352
	NS328VPL	3/8	1/2	NS353 NS354
	NS524VPL	1/2	1/2	NS554 (F) (FB) 556 (FB)
	NS526VPL	1/2	3/4	NS554 (F) (FB) 556 (FB)

Description	Part Number	Nominal Passage	Hose I. D.	Fit Any Plug Number
<b>90° Stem</b>	NS214VPL	1/4	1/4	NS252
	NS216VPL	1/4	3/8	NS253
	NS316VPL	3/8	3/8	NS352
	NS318VPL	3/8	1/2	NS353 NS354

Note: Use "Push-to-Lock" type hose only. Connector Sockets are for use with water and water-based coolants only. Although Connector Sockets are suitable for temperatures to 400°F, observe the temperature ratings of your "push-to-lock" hose. Most "push-to-lock" hoses have a temperature rating of 175°F or less. Never exceed 200 PSI.





# Water Couplers

## Push To Connect/Push To Lock, Auto Two-Way Shutoff

### With Clampless Hose Stems for use with Push-To-Connect/Push-To-Lock Type Hose

- For use with push-to-connect/push-to-lock type hose only
- Saves setup time by eliminating the need for hose clamps
- Hose stem barbs mate with "Push-to-Lock" style rubber hose
- Popular sizes for interchangeability with existing and SV sockets
- More compact and consistently sized than competitive sockets
- Leakproof brass and stainless steel construction
- Replaceable seals and valves for long service life
- Socket connector seals are Viton



### [PUSH TO CONNECT WATER COUPLERS](#)

Description	Part Number	Nominal Passage	Hose I. D.	Fit Any Plug Number
 Straight Stem	NS204SVPL	1/4	1/4	NS252SV
	NS206SVPL	1/4	3/8	NS253SV
	NS306SVPL	3/8	3/8	NS352SV
	NS308SVPL	3/8	1/2	NS353SV NS354SV

Description	Part Number	Nominal Passage	Hose I. D.	Fit Any Plug Number
 45° Stem	NS224SVPL	1/4	1/4	NS252SV
	NS226SVPL	1/4	3/8	NS253SV
	NS326SVPL	3/8	3/8	NS352SV
	NS328SVPL	3/8	1/2	NS353SV NS354SV

Description	Part Number	Nominal Passage	Hose I. D.	Fit Any Plug Number
 90° Stem	NS214SVPL	1/4	1/4	NS252SV
	NS216SVPL	1/4	3/8	NS253SV
	NS316SVPL	3/8	3/8	NS352SV
	NS318SVPL	3/8	1/2	NS353SV NS354SV

Note: Use "Push-to-Lock" type hose only. Connector Sockets are for use with water and water-based coolants only. Although Connector Sockets are suitable for temperatures to 400°F, observe the temperature ratings of your "push-to-lock" hose. Most "push-to-lock" hoses have a temperature rating of 175°F or less. Never exceed 200 PSI.

# Water Couplers



## Valved/Non-Valved

### Coupler - Valved & Non-valved body only

Part Number	Description	Thread Size
NS200	1/4" Passage - 200 Series	1/8"
NS200SV*	1/4" Passage - 200 Series Valved*	1/8"
NS300	3/8" Passage - 300 Series	1/4"
NS300HF	7/16" Passage - 300 Series High Flow	3/8"
NS300SV*	3/8" Passage - 300 Series Valved*	1/4"
NS500	1/2" Passage - 500 Series	1/2"

\*Valved couplers include: Coupler, Valve & Spring - Complete

### VALVED-NON VALVED

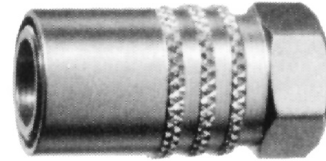

### Positive Sleeve Lock Sockets - Non-valved

Part Number	Description
NS200SL	1/8" Thread - Use with 200 Series Plug
NS300SL	1/4" Thread - Use with 300 Series Plug
NS300HFSL	3/8" Thread - Use with 300 Series Plug
NS500SL	1/2" Thread - Use with 500 Series Plug



## Washers

Part Number	Description
SW200*	Silicone Washers for 200 Series
VW200*	Viton® Washers for 200 Series
SW300*	Silicone Washers for 300 Series
VW300*	Viton® Washers for 300 Series
SW500*	Silicone Washers for 500 Series
VW500*	Viton® Washers for 500 Series

\*Add -12 (for bag of 12) or -100 (for bag of 100) to the part number.

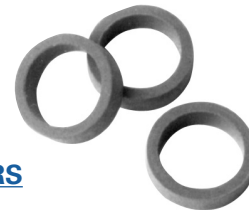

### WASHERS

Temperature Range	Silicone	Viton
	-90F to 400F	-15F to 400F

E

## Retaining Clips (for water couplers)

### Helps prevent accidental release of water couplers

- Avoids unnecessary spills
- Available in 200,300 and 500 series
- 2 colors: red for hot, blue for cold
- Made of nylon
- Universal, fits most water couplers
- Max rating is 400 degrees F

Fits securely to help prevent release of water coupler

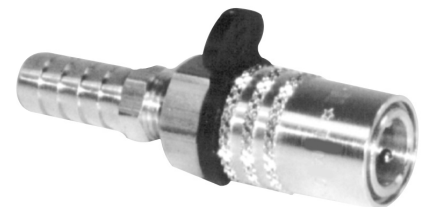

### RETAINING CLIPS

Part Number	Series	Inside Diameter	Thickness
C200*	200	.59	.11
C300*	300	.79	.14
C500*	500	1.16	.15

\*Add -R for red or -B for blue







# Water Plugs

## For Mold Connections

### MALE PLUGS

#### Brass & Steel Male Water Plugs

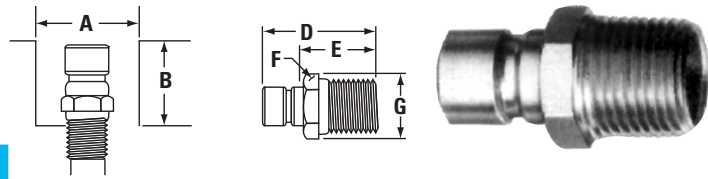

Series	Part Number	Material	Passage Size	NPT Size	Dia. A	Depth B	O.A.L. D	EXP. E	HEX F	LGST. G
200	NS250	Brass	3/16	1/16	.69	.69	.94	.54	.38	.43
	NS251	Brass	1/4	1/8	.69	.69	.94	.54	.56	.51
	NS252	Brass	1/4	1/4	.84	.94	1.13	.74	.56	.67
	NS252S	Steel	1/4	1/4	.84	.94	1.13	.74	.56	.67
	NS253	Brass	1/4	3/8	1.00	.97	1.19	.79	.69	.79
300	NS351	Brass	3/8	1/8	1.00	.94	1.19	.58	.56	.65
	NS352	Brass	3/8	1/4	1.00	.94	1.34	.74	.56	.65
	NS352S	Steel	3/8	1/4	1.00	.94	1.34	.74	.56	.65
	NS353	Brass	3/8	3/8	1.00	1.13	1.38	.78	.69	.79
	NS354	Brass	3/8	1/2	1.18	1.25	1.59	.99	.88	1.01
500	NS554	Brass	1/2	1/2	1.25	1.50	1.69	.92	.88	1.01
	NS556	Brass	1/2	3/4	1.50	1.56	1.75	.99	1.13	1.30

#### Valved Water Plugs

#### VALVED PLUGS

Part Number	Material	Passage Size	NPT Size	Dia. A	Depth B	O.A.L. D	EXP. E	HEX F	LGST. G
NS252SV	Brass	1/4	1/4	.84	.94	1.13	.74	.56	.67
NS253SV	Brass	1/4	1/4	.84	.94	1.13	.74	.56	.67
NS352SV	Brass	3/8	1/4	1.00	.94	1.34	.74	.56	.65
NS353SV	Brass	3/8	3/8	1.00	.94	1.34	.74	.56	.65
NS354SV	Brass	3/8	1/2	1.00	.94	1.34	.74	.56	.65

#### Steel Female (plated to prevent rust)

#### STEEL FEMALE

Series	Part Number	Material	Passage Size	NPT Size	O.A.L. D	EXP. E	HEX F	LGST. G
200	NS251F	Steel	1/4	1/8	.97	.58	.50	.58
	NS252F	Steel	1/4	1/4	1.28	.89	.63	.72
	NS253F	Steel	1/4	3/8	1.41	1.03	.75	.87
300	NS352F	Steel	3/8	1/4	1.48	.88	.63	.72
	NS353F	Steel	3/8	3/8	1.58	.98	.75	.87
	NS354F	Steel	3/8	1/2	1.66	1.45	.94	1.09
500	NS554F	Steel	1/2	1/2	1.75	.98	.94	1.07

#### Brass Female

#### BRASS FEMALE

Series	Part Number	Material	Passage Size	NPT Size	O.A.L. D	EXP. E	HEX F	LGST. G
200	NS250FB	Brass	1/4	1/16	.75	.39	.38	.43
	NS251FB	Brass	1/4	1/8	.97	.58	.50	.58
	NS252FB	Brass	1/4	1/4	1.28	.89	.63	.72
	NS253FB	Brass	1/4	3/8	1.41	1.03	.75	.87
300	NS351FB	Brass	11/32	1/8	1.00	.42	.56	.64
	NS352FB	Brass	3/8	1/4	1.48	.88	.63	.72
	NS353FB	Brass	3/8	3/8	1.58	.98	.75	.87

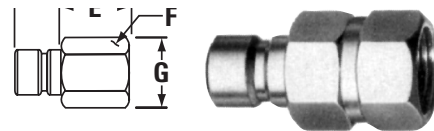

**Pipe Check** is an easy way to check a pipe thread. This handy tool can check pipe sizes from 1/16" thru 1/2" for a number of applications.

## PC-100

PC-100 simply determines the size of pipes from 1/16" to 1/2" NPT. Made entirely of heavy gauge aluminum, this model is perfect for the office, warehouse, or factory floor. Just turn the thread into the hole that fits to determine pipe size.

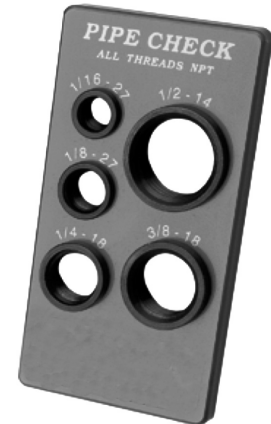

**PIPE CHECK**

## Pipe Thread Data

Most ordering mistakes are caused by measuring the pipe size of the fitting or component incorrectly. The nominal size of any pipe does not in fact refer to either the outside diameter (O.D.) or the inside diameter (I.D.) of the pipe. The table lists standard pipe sizes along with the actual O.D. and I.D. for each size. Keep in mind that manufacturers may slightly modify these dimensions to strengthen or enhance the performance of a product.

Pipe Size	Threads Per Inch	Outside Dia. of Pipe	Inside Diameter of Pipe	Tap Drill Size Without Ream	Tap Drill Size With Ream	E
1/16	27	.312	.209	1/4	15/64	.261
1/8	27	.405	.269	11/32	21/64	.263
1/4	18	.540	.364	7/16	27/64	.395
3/8	18	.675	.493	9/16	9/16	.407
1/2	14	.840	.622	45/64	11/16	.534
3/4	14	1.050	.824	29/32	57/64	.545
1	11 1/2	1.315	1.049	1 9/64	1 1/8	.661
1 1/4	11 1/2	1.660	1.380	1 31/64	1 15/32	.681
1 1/2	11 1/2	1.900	1.610	1 23/32	1 45/64	.681
2	11 1/2	2.375	2.067	2 3/16	2 11/64	.697

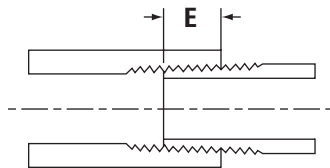

Once the correct pipe size has been determined, the "E" dimension may be used to determine the length of the component required to assemble properly when fully tightened.

### Pipes shown actual size

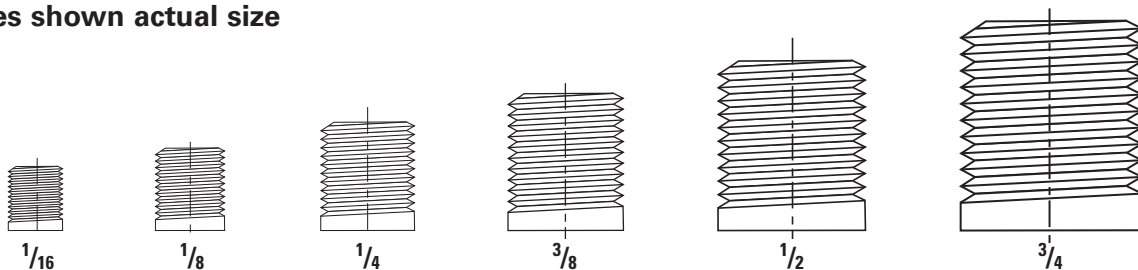



# Extension Plugs

## Solid Brass



British Standard Thread also available!

- Positive removal
- No rust; brass
- In stock!!
- Flush mount for easy mold handling
- Cut to any length
- Low, low prices
- Leak-free extensions

### 1/16" Pipe Extensions

Part Number	Length	Pipe Size	Hex Size	A	Part Number	Length	Pipe Size	Hex Size	A
250X212	2.5"	1/16	3/8	11/16	350X212	2.5"	1/16	9/16	7/8
250X4	4	1/16	3/8	13/16	350X4	4	1/16	9/16	1
250X7	7	1/16	3/8	13/16	350X7	7	1/16	9/16	1

### 1/8" Pipe Extensions

251X212	2.5"	1/8	7/16	11/16	351X212	2.5	1/8	9/16	7/8
251X4	4	1/8	7/16	1	351X4	4	1/8	9/16	1
251X512	5.5	1/8	7/16	1	351X512	5.5	1/8	9/16	1
251X7	7	1/8	7/16	1	351X7	7	1/8	9/16	1
251X812	8.5	1/8	7/16	1	351X812	8.5	1/8	9/16	1
251X10	10	1/8	7/16	1	351X10	10	1/8	9/16	1
251X1112	11.5	1/8	7/16	1	351X1112	11.5	1/8	9/16	1
251X13	13	1/8	7/16	1	351X13	13	1/8	9/16	1

### 1/4" Pipe Extensions

252X212	2.5"	1/4	9/16	7/8	352X212	2.5"	1/4	9/16	7/8
252X4	4	1/4	9/16	1 1/4	352X4	4	1/4	9/16	1 1/4
252X512	5.5	1/4	9/16	1 1/4	352X512	5.5	1/4	9/16	1 1/4
252X7	7	1/4	9/16	1 1/4	352X7	7	1/4	9/16	1 1/4
252X812	8.5	1/4	9/16	1 1/4	352X812	8.5	1/4	9/16	1 1/4
252X10	10	1/4	9/16	1 1/4	352X10	10	1/4	9/16	1 1/4
252X1112	11.5	1/4	9/16	1 1/4	352X1112	11.5	1/4	9/16	1 1/4
252X13	13	1/4	9/16	1 1/4	352X13	13	1/4	9/16	1 1/4

### EXTENSION PLUGS

### 3/8" Pipe Extensions

253X212	2.5"	3/8	11/16	1
253X4	4	3/8	11/16	1 1/4
253X512	5.5	3/8	11/16	1 1/4
253X7	7	3/8	11/16	1 1/4
253X812	8.5	3/8	11/16	1 1/4
253X10	10	3/8	11/16	1 1/4
253X1112	11.5	3/8	11/16	1 1/4
253X13	13	3/8	11/16	1 1/4
353X212	2.5"	3/8	11/16	1
353X4	4	3/8	11/16	1 1/4
353X512	5.5	3/8	11/16	1 1/4
353X7	7	3/8	11/16	1 1/4
353X812	8.5	3/8	11/16	1 1/4
353X10	10	3/8	11/16	1 1/4
353X1112	11.5	3/8	11/16	1 1/4
353X13	13	3/8	11/16	1 1/4
553X212	2.5"	3/8	13/16	1 1/8
553X4	4	3/8	13/16	1 3/8
553X512	5.5	3/8	13/16	1 3/8
553X7	7	3/8	13/16	1 3/8
553X812	8.5	3/8	13/16	1 3/8
553X10	10	3/8	13/16	1 3/8
553X1112	11.5	3/8	13/16	1 3/8
553X13	13	3/8	13/16	1 3/8

### 1/2" Pipe Extensions

354X212	2.5"	1/2	7/8	1 1/8
354X4	4	1/2	7/8	1 1/2
354X512	5.5	1/2	7/8	1 1/2
354X7	7	1/2	7/8	1 1/2
354X812	8.5	1/2	7/8	1 1/2
354X10	10	1/2	7/8	1 1/2
354X1112	11.5	1/2	7/8	1 1/2
354X13	13	1/2	7/8	1 1/2
554X212	2.5"	1/2	7/8	1 1/8
554X4	4	1/2	7/8	1 1/2
554X512	5.5	1/2	7/8	1 1/2
554X7	7	1/2	7/8	1 1/2
554X812	8.5	1/2	7/8	1 1/2
554X10	10	1/2	7/8	1 1/2
554X1112	11.5	1/2	7/8	1 1/2
554X13	13	1/2	7/8	1 1/2

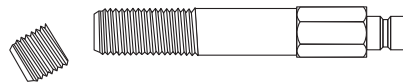
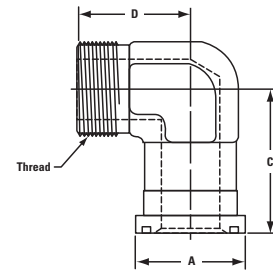

Simply cut piece to length and chamfer end. Turn into standard pipe threading die to retaper end threads. Pre-cut threads allow die to turn easily, and guide the die for smooth threads that are always straight and square.

# Extension Plugs

Solid Brass



Brass Extension Plugs are designed to eliminate the installation problems of soldering, welding, etc. of connector plugs to steel pipe nipples. Length adjustments (when required) are easy and accurate with pre-cut pipe thread system.

Once installed, the advantages of flush-mounted mold connector plugs are many. Sealing surfaces of plugs are protected, while handling and storage of the mold are made easier.

Brass Extension Plugs offer ease of installation, leak-free performance, and complete removability. In stock in all standard lengths and thread sizes, these extensions may also be ordered cut to any exact length required, and in any quantity.

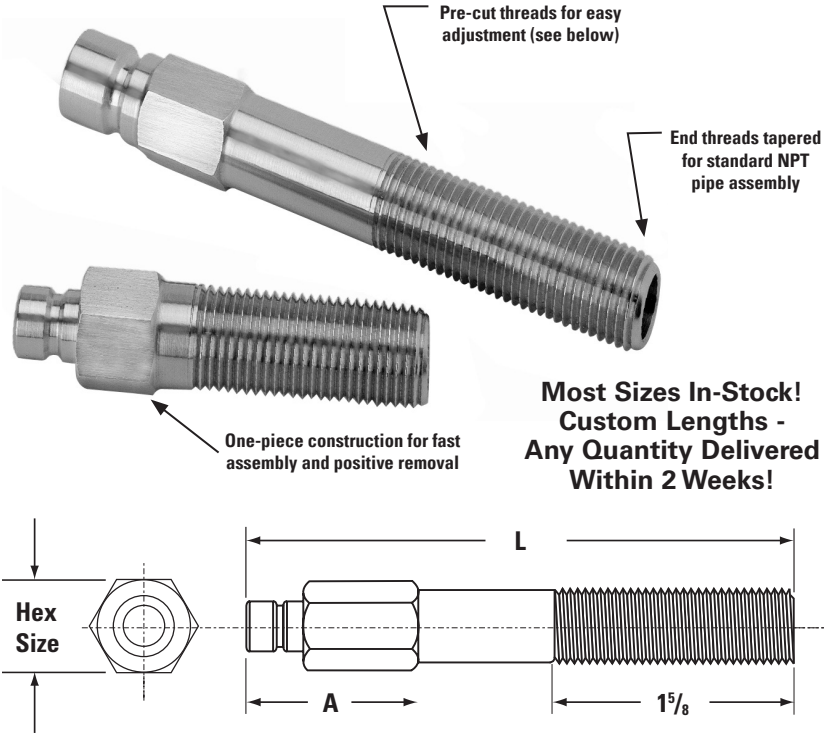

**Most Sizes In-Stock!  
Custom Lengths -  
Any Quantity Delivered  
Within 2 Weeks!**

## Custom Lengths Are Easy to Make!

### Length Adjustments & Installation

1. When special length adjustments are required, simply cut piece to length and chamfer end.
2. Turn into standard pipe threading die to re-taper threads.

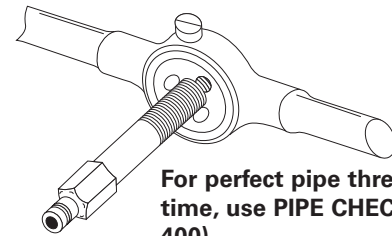
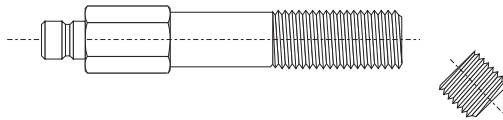

**For perfect pipe threads every time, use PIPE CHECK (see Page 400).**

3. At assembly, the tapered brass threads provide a dependable, leak-proof seal. With one-piece construction, removability is always guaranteed.

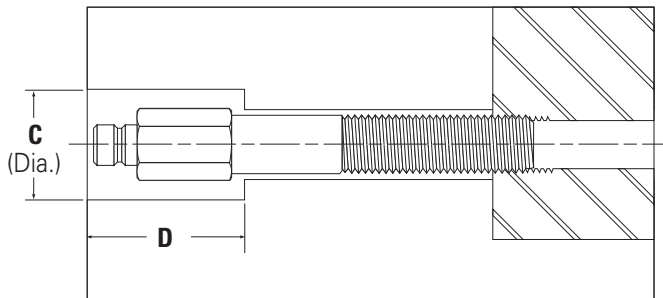

Extension Series	C (Dia.)	D
250	3/4	1
251	7/8	1 1/4
252	1	1 1/2
253	1 1/8	1 1/2
350	1	1 1/4
351	1	1 1/4
352	1	1 1/2
353	1 1/8	1 1/2
554	1 1/2	1 3/4
553	1 3/8	1 5/8
554	1 1/2	1 3/4



# Combination Hose Insert

Our Combination Hose Inserts offer compact, versatile connections without the use of multiple fittings and assemblies. When machine cooling manifolds are equipped with socket connector bodies, hoses should have a combination hose insert on one end, and a socket connector on the other. In this way, hoses may be connected from manifold to mold, or snapped together in series for longer-reach situations.

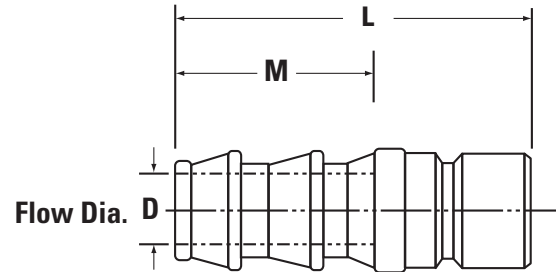

## COMBINATION HOSE BARBS

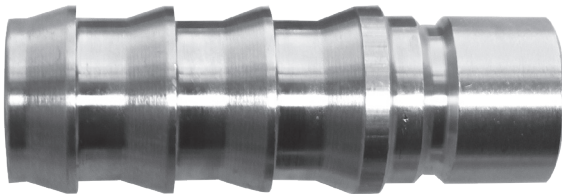
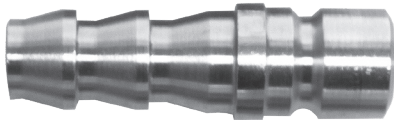
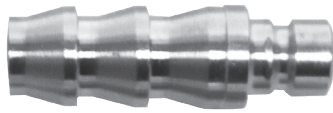

200 SERIES 1/4" Hole	Part Number	Hose I.D.	Dimensions		
			D	M	L
	200-4	1/4	3/16	7/8	1 3/8
	200-5	5/16	1/4	7/8	1 3/8
	200-6	3/8	1/4	1 1/16	1 9/16
	200-8	1/2	1/4	1 1/16	1 9/16

300 SERIES 3/8" Hole	Part Number	Hose I.D.	Dimensions		
			D	M	L
	300-4	1/4	3/16	7/8	1 13/16
	300-6	3/8	9/32	1 1/16	1 13/16
	300-8	1/2	1 1/32	1 1/16	1 13/16

500 SERIES 1/2" Hole	Part Number	Hose I.D.	Dimensions		
			D	M	L
	500-8	1/2	13/32	1 1/16	2
	500-12	3/4	9/16	1 1/2	2 1/2

## Cover Plugs

Mold Cover Plugs conveniently snap into socket connectors to stop coolant flow. Uses include plugging extra ports on machine cooling manifolds, and to stop hose drainage during mold changes.

Part Number	Fits Socket Number
CP200	200 (1/4" nominal)
CP300	300 (3/8" nominal)
CP500	500 (1/2" nominal)



# Quick-Coupler Water Jumpers



Standard

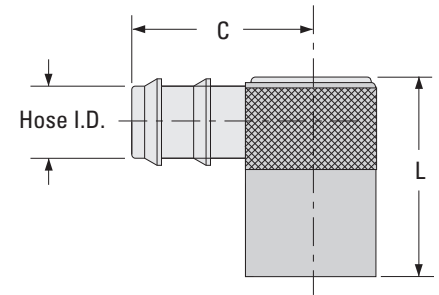
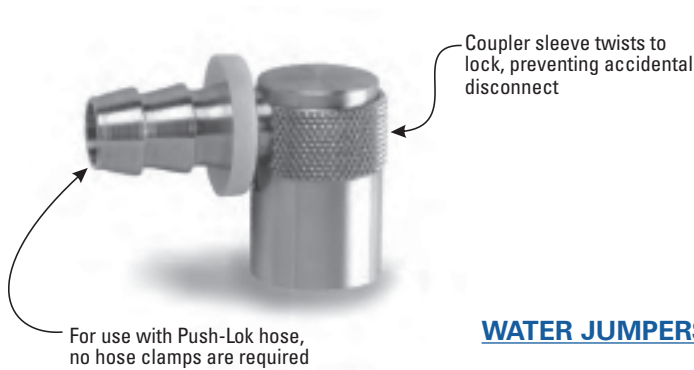

## WATER JUMPERS

Part Number	Hose I.D.	Fits Plug Series No.	Measurements (refer to drawings)		
			L	C	M
WJ200-4	1/4	200	1	1 1/4	3/8
WJ200-5	5/16	200	1	1 1/4	3/8
WJ200-6	3/8	200	1	1 1/4	3/8
WJ300-6	3/8	300	1 7/16	1 9/16	1/2
WJ300-8	1/2	300	1 7/16	1 9/16	1/2
WJ500-8	1/2	500	2 1/8	2	7/8
WJ500-12	3/4	500	2 1/8	2	7/8

- Oversized and unrestricted flow path maintains full flow rate of hose used
- Compact design neatly and safely holds cooling lines close to the mold surface
- Exclusive Locking Sleeve prevents accidental disconnect and ensures proper installation
- Unlimited installation options; fits around obstacles, and installs in compact spaces
- All brass and stainless steel construction
- Viton seals withstand temps up to 400°F
- Compatible with all major mold connection systems

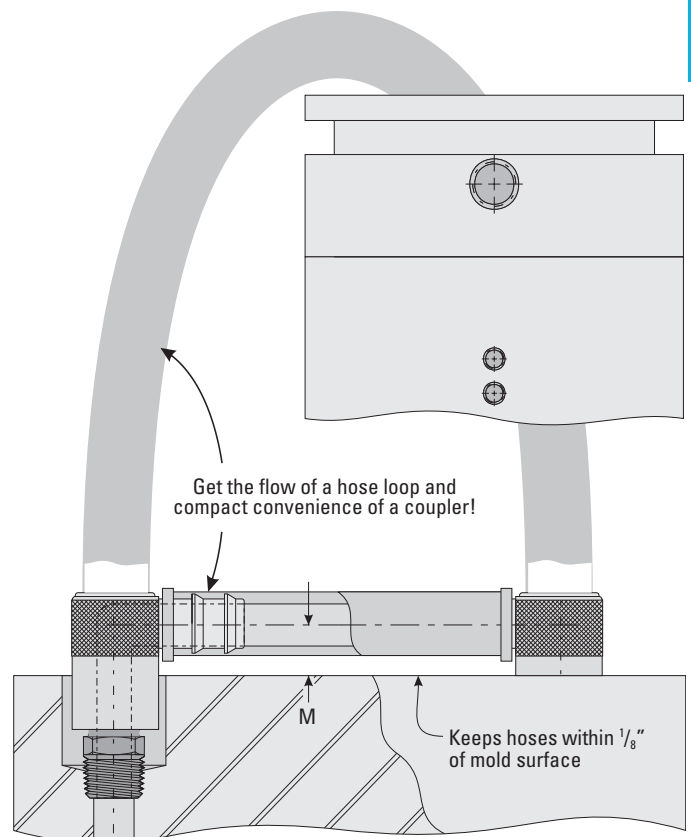





# Quick Coupler Water Jumpers

## Swivel Head

- Can be fully recessed to prevent accidental disconnect or damage
- Swivel body allows for installation in tight spaces
- Eliminate crimped hoses and setup errors
- Viton O-ring seals
- All brass construction
- Easy hex key installation
- Custom length water jumpers available

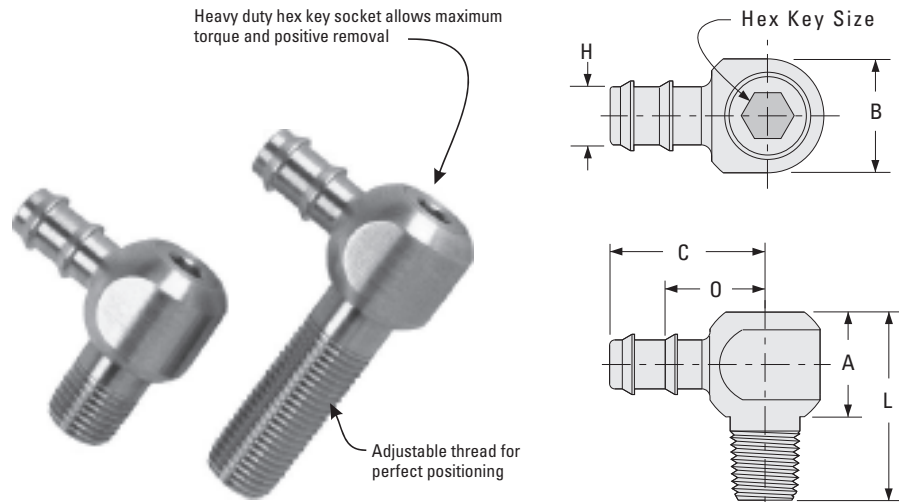

### WATER JUMPERS

Part Number	Pipe Size (NPT)	Hose I.D.	Hex Key Size	Measurements (refer to drawing above)					For Recessed Installation	
				L	A	C	O	B	Min. Slot Width	Min. Slot Depth
WJ18S	1/8	5/16	3/16	1 3/16	1 1/16	1	5/8	.660	1 1/16	1
WJ18M	1/8	5/16	3/16	2	1 1/16	1	5/8	.660	1 1/16	1
WJ18L	1/8	5/16	3/16	3 1/2	1 1/16	1	5/8	.660	1 1/16	1
WJ14S	1/4	3/8	1/4	1 7/16	1 3/16	1 3/16	25/32	.840	7/8	1 3/16
WJ14M	1/4	3/8	1/4	2 3/8	1 3/16	1 3/16	25/32	.840	7/8	1 3/16
WJ14L	1/4	3/8	1/4	3 7/8	1 3/16	1 3/16	25/32	.840	7/8	1 3/16
WJ38S	3/8	1/2	5/16	1 5/8	1	1 3/8	15/16	.980	1	1 3/8
WJ38M	3/8	1/2	5/16	2 5/8	1	1 3/8	15/16	.980	1	1 3/8
WJ38L	3/8	1/2	5/16	4 1/8	1	1 3/8	15/16	.980	1	1 3/8
WJ50S	1/2	3/4	3/8	2	1 1/8	1 1/2	1 1/8	1.235	1 1/4	1 9/16
WJ50M	1/2	3/4	3/8	3	1 1/8	1 1/2	1 1/8	1.235	1 1/4	1 9/16
WJ50L	1/2	3/4	3/8	4 1/2	1 1/8	1 1/2	1 1/8	1.235	1 1/4	1 9/16

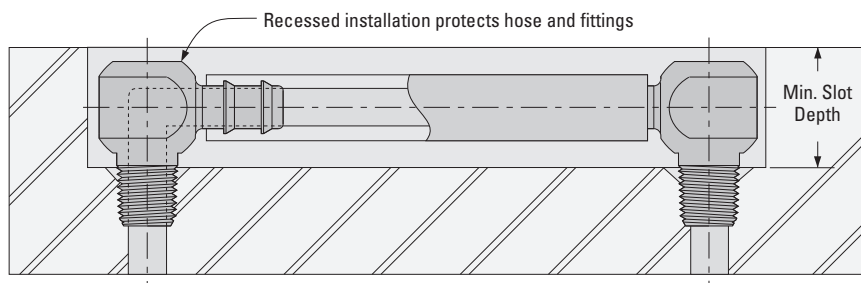
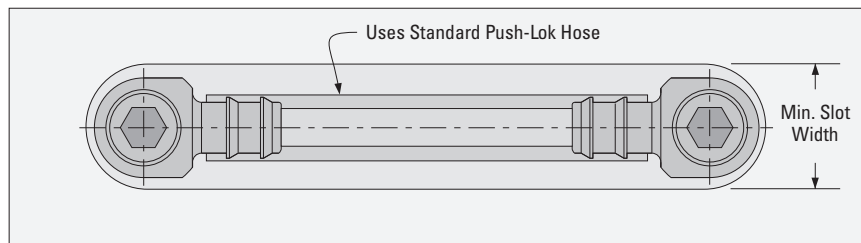
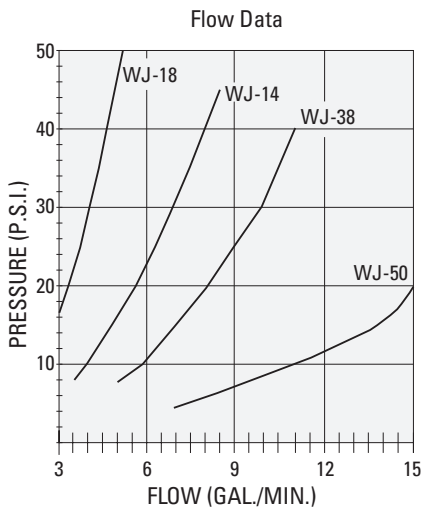

### To Increase Production up to 65% Just Add Water

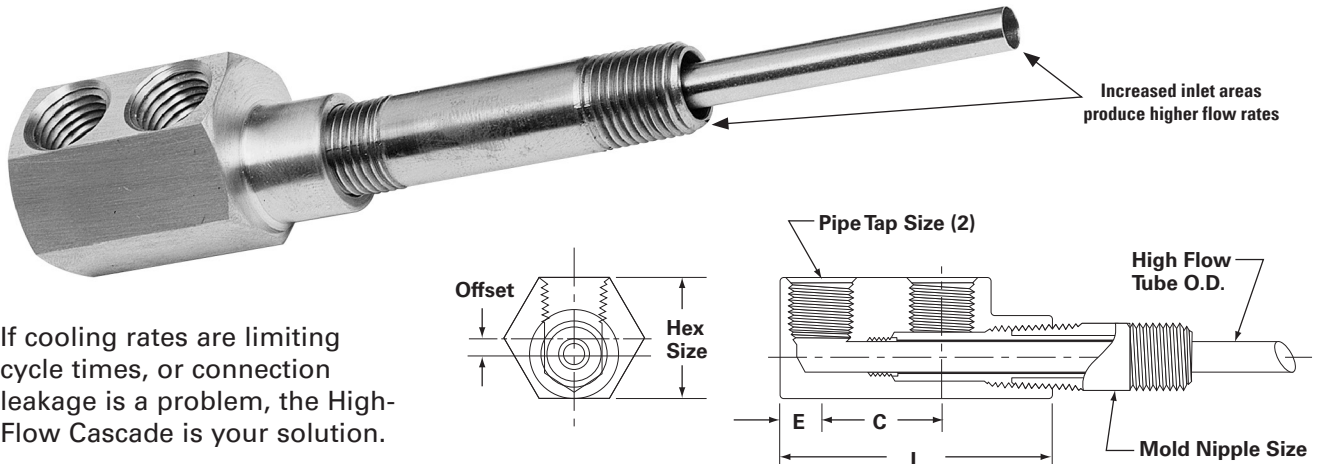

If cooling rates are limiting cycle times, or connection leakage is a problem, the High-Flow Cascade is your solution.

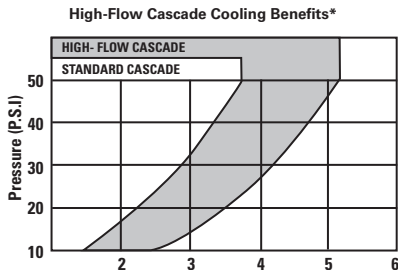

\*The performance of the High-Flow Cascade Series was recently tested and compared to existing nipple-type cascades through experimentation conducted at the University of Wisconsin-Milwaukee.

A computerized heat transfer analysis was conducted and an overall energy balance was performed. It was found that the heat transfer rate was dependent largely on the mass flow rate of the coolant. The greater the mass flow rate of the coolant, the greater the overall heat transfer rate of the cascade. The test results are summarized in graphical form and shown above.

This data shows the new design creates a 35%–65% increase in overall cooling rates.

The High-Flow Cascade Series has been engineered to provide the mold user with a leak-free cooling system capable of maintaining faster cycle time settings.

Tests have proven that the High-Flow Cascade Water Junction cools between 35%–65% faster, and eliminates leaks caused by pipe nipple interference.\*

The High-Flow Cascade increases flow rates by using a thin-walled stainless steel tube and a new offset design. By eliminating the pipe plug and offsetting the mold nipple in the brass head, all connecting pipes can be completely tightened without interference or choking off flow. The High-Flow stainless tubes can be adjusted to any length and are threaded into the solid brass head for firm support.

Basic sizes and center distances are interchangeable with existing units. Brass heads can be ordered separately along with tubes in any length.

If water junction cooling rates are limiting your cycle times, or connection leakage is a problem, the High-Flow Cascade Water Junction is your solution.





# Cascade Assemblies

## High-Flow

See the table below for complete dimensional design data. The table also shows the actual percent increase in cooling that a particular cascade will produce compared to a corresponding standard flow model.

Please note tube thread size (when using tubes only), and offset dimension (for swing clearance on internal installations).

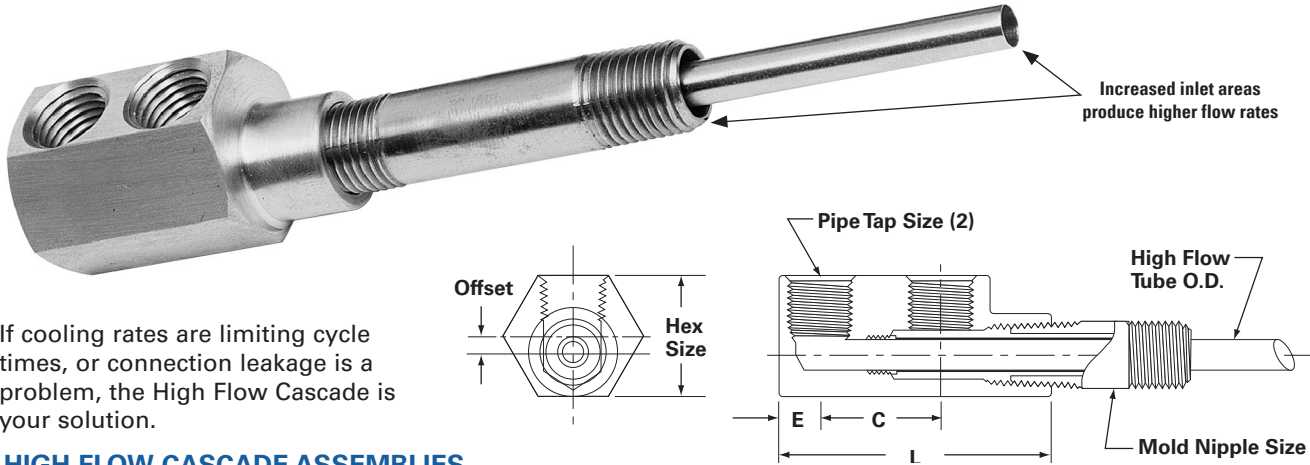

If cooling rates are limiting cycle times, or connection leakage is a problem, the High Flow Cascade is your solution.

### HIGH FLOW CASCADE ASSEMBLIES

Mold Part Number	In/Out Nipple (NPT)	Tube Pipe Sz. (NPT)	O.D. (12" lg)	Hex Size	Offset	E	C	L	% Actual Flow Increase
HF16N	1/16	1/16	1/8	5/8	3/32	1/4	1/2	1 1/4	—
HF186N	1/8	1/8	3/16	3/4	3/32	5/16	1 1/16	1 5/8	64%
HF181N	1/8	1/8	3/16	3/4	3/32	5/16	1	1 15/16	64%
HF146N4	1/4	1/4	1/4	1	5/32	1 1/32	1 1/16	1 7/8	48%
HF141N4	1/4	1/4	1/4	1	5/32	1 1/32	1	2 3/16	48%
HF381N4	3/8	1/4	3/8	1	1/8	1 1/32	1	2 1/4	38%

### High-Flow Cascade Heads

All dimensions same as above for corresponding part number. Use High-Flow Tubes only.

Part Number	High Flow Tube No.
HF16H	HF125T
HF186H	HF187T
HF181H	HF187T
HF146H4	HF250T
HF141H4	HF250T
HF381H4	HF375T

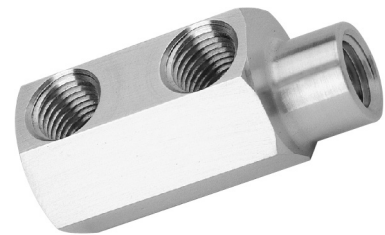

### High-Flow Cascade Tubes

Thin-walled stainless steel tubes have precision threaded end. Please note thread size when using tubes only.

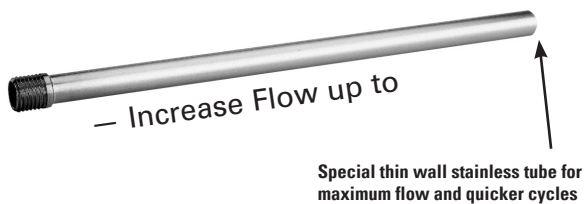

Part Number	Tube O.D.	Tube I.D.	Tube Length	Std. Thread Size	Thread Length
HF125T	.125	.105	12"	10-32	3/16
HF187T	.187	.167	12"	1/4-28	1/4
HF250T	.250	.230	12"	5/16-24	5/16
HF312T	.312	.280	12"	3/8-24	3/8
HF375T	.375	.335	12"	7/16-20	7/16

# Nipple Type Cascade

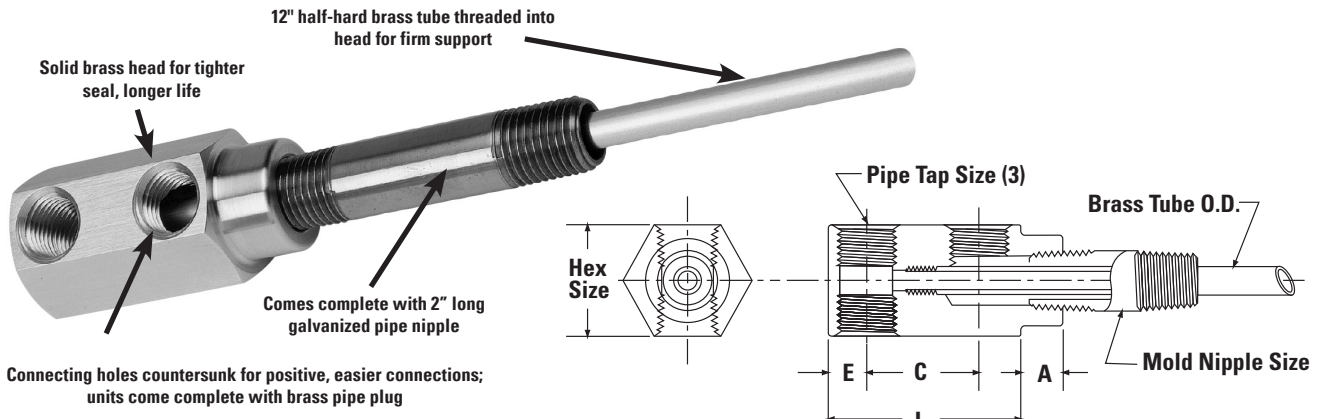

Connecting holes countersunk for positive, easier connections; units come complete with brass pipe plug

## Nipple Type Cascades

Part Number	Nipple Size	Tap Size (NPT)	Tube O.D.*	Hex Size	E	C	A	L
16N	1/8	1/16	3/16	3/4	7/32	1/2	9/32	15/16
186N	1/8	1/8	3/16	7/8	21/64	11/16	9/32	1 1/32
181N	1/8	1/8	3/16	7/8	21/64	1	9/32	1 21/32
146N	1/4	1/8	1/4	1	21/64	11/16	7/32	1 11/32
146N4	1/4	1/4	1/4	1	21/64	11/16	7/32	1 11/32
141N	1/4	1/8	1/4	1	21/64	1	7/16	1 21/32
141N4	1/4	1/4	1/4	1	21/64	1	7/16	1 21/32
381N	3/8	1/8	5/16	1	11/32	1	13/32	1 11/16
381N4	3/8	1/4	5/16	1	11/32	1	13/32	1 11/16
121N4	1/2	1/4	7/16	1 1/4	13/32	1	9/16	1 13/16
341N4	3/4	3/8	5/8	1 1/2	1/2	1 1/4	3/4	2 1/4

\*Extra length Tubes available from stock.

## NIPPLE TYPE CASCADE

# Extension Tubes & Cascade Heads

Half-hard brass extension tubes - one end threaded for easy assembly. Tubes are also available with both ends threaded, and in custom lengths.



EXTENSION TUBES

## Extension Tubes

Part Number	Tube O. D.	Tube I. D.	Tube Length*	Thread	Thread Length
125T	.125	.062	12	5-44	3/16
187T	.187	.123	12	10-32	3/16
250T	.250	.170	12	1/4-28	1/4
312T	.312	.210	12	5/16-24	5/16
375T	.375	.273	12	3/8-24	3/8
437T	.437	.307	12	7/16-20	7/16
625T	.625	.495	12	5/8-18	5/8

\*Extra length Tubes available

## SOLID BRASS CASCADE HEADS

Cascade Heads	
Part Number	Tube Number
16H	187 T
186H	
181H	
146H	250 T
146H4	
141H	
141H4	312 T
381H	
381H4	437 T
121H4	625 T
341H4	



**Solid Brass Cascade Heads**  
All holes threaded. All dimensions same as above for corresponding part number. Complete with brass pipe plug.



# Compact Cascades

Compact Cascades are designed for use where a standard Nipple-Type or One-Piece Cascade may not fit. Ports are positioned sideways for mounting into thin mold plates, or where other cooling lines limit clearances for pipe connections. Tube and mold nipple length adjustments are made exactly as with a Nipple-Type Cascade. Flow rates are equivalent, and no pipe plugs are required. These units are available in four sizes, and are in stock for immediate delivery.

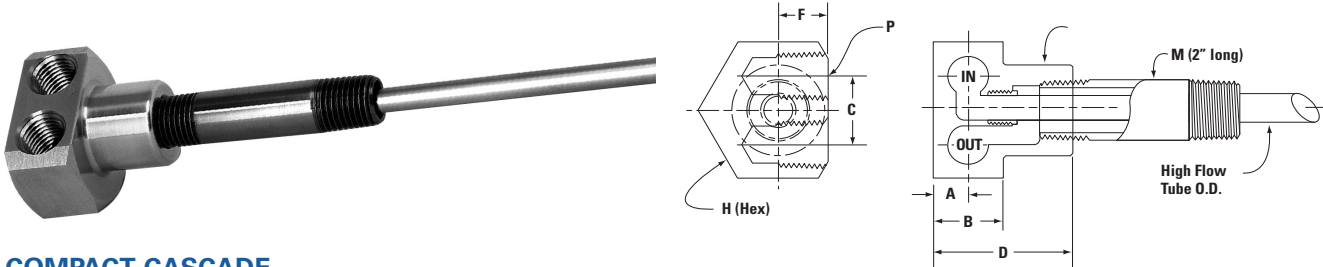

## COMPACT CASCADE

Mold Part Number	Pipe Nipple M	Hex Tap P	Tube Size H	O.D. T	A	B	C	D	E
ET1816	1/8	1/16	15/16	3/16	7/32	7/16	1/2	1	5/8
ET1418	1/4	1/8	1 1/4	1/4	5/16	5/8	11/16	1 1/4	3/4
ET1414	1/4	1/4	1 1/2	1/4	3/8	3/4	3/4	1 1/2	7/8
ET3814	3/8	1/4	1 1/2	5/16	3/8	3/4	3/4	1 1/2	1

# Hex Cascade Assemblies

- High-flow design provides maximum cooling ratings
- Easy to install and remove
- Assemblies include brass head, 12" high-flow stainless tube, and 2" long galvanized pipe nipple



## HEX CASCADE

Hex Key Cascades are round and install with an Allen wrench. They may be installed with minimal clearance or very close together where space is limited.

Mold Part Number	Pipe Nipple M	High Flow Tap Size	Tube O.D. (12" LG)	L	C	A	Hex Key Size	Nominal Clearance Drill	Actual O.D.
E16N	1/16	1/16	1/8	1.625	9/16	1/2	5/16	5/8	.610
E16N2	1/8	1/16	3/16	1.687	9/16	9/16	3/8	3/4	.735
E186N	1/8	1/8	3/16	1.875	11/16	9/16	3/8	7/8	.860
E181N	1/8	1/8	3/16	2.187	1	9/16	3/8	7/8	.860
E146N	1/4	1/8	1/4	2.187	11/16	13/16	1/2	1	.985
E146N4	1/4	1/4	1/4	2.312	11/16	7/8	1/2	1	.985
E141N	1/4	1/8	1/4	2.500	1	13/16	1/2	1	.985
E141N4	1/4	1/4	1/4	2.625	1	7/8	1/2	1	.985
E381N4	3/8	1/4	5/16	2.625	1	7/8	1/2	1	.985
E121N4	1/2	1/4	3/8	2.812	1	1	1/2	1 1/4	1.235

# Brass Extension Elbows



## BRASS EXTENSION ELBOWS

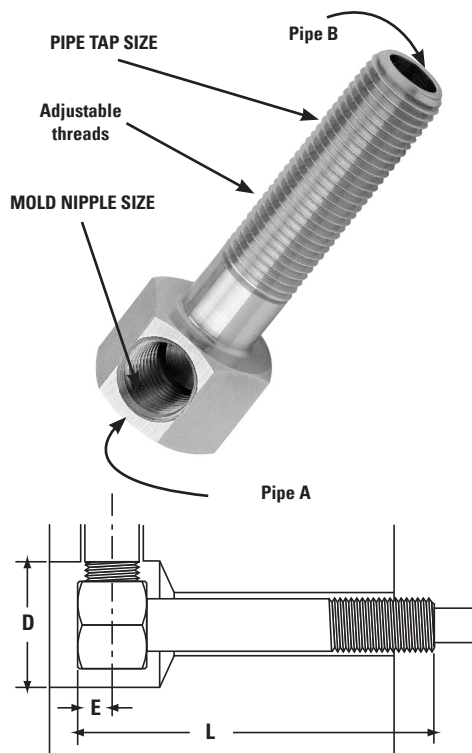

Solid Brass Hex Extension Elbows feature one-piece re-direction of mold cooling lines and adjustable threads for easy alignment in the mold. Socket wrench installation requires minimum turning clearance, while one-piece construction ensures complete removal...every time!

Part Number	Nipple Size	Tap Size	Hex Size	D	E	L*
18BX212	1/8	1/8	3/4	1 1/4	9/32	2 1/2
18BX4	1/8	1/8	3/4	1 1/4	9/32	4
1814BX212	1/4	1/8	3/4	1 1/4	9/32	2 1/2
1814BX4	1/4	1/8	3/4	1 1/4	9/32	4
14BX212	1/4	1/4	7/8	1 3/8	11/32	2 1/2
14BX4	1/4	1/4	7/8	1 3/8	11/32	4
1438BX212	3/8	1/4	7/8	1 3/8	11/32	2 1/2
1438BX4	3/8	1/4	7/8	1 3/8	11/32	4
38BX212	3/8	3/8	1	1 1/2	1/2	2 1/2
38BX4	3/8	3/8	1	1 1/2	1/2	4
50BX212	1/2	1/2	1 1/4	1 3/4	5/8	2 1/2
50BX4	1/2	1/2	1 1/4	1 3/4	5/8	4

\* Longer length Extension Elbows are available

## Steel Hex Elbows

Steel Hex Elbows are used in longer reach applications or where a steel pipe nipple assembly is required. Outside, these elbows offer easy socket wrench installation, and minimum turning clearance "D". Inside, is an exclusive angular connecting hole (see diagram), which allows pipes to be torqued tight without choking off flow. These elbows are available in pipe sizes from 1/16" to 3/4" NPT, and are zinc plated to resist rust and corrosion.

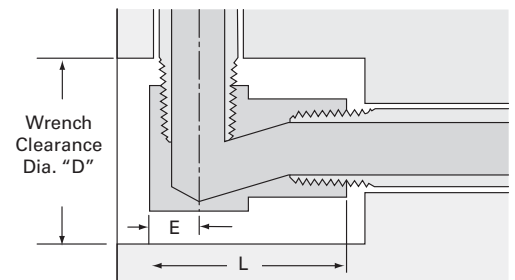

## STEEL HEX ELBOWS

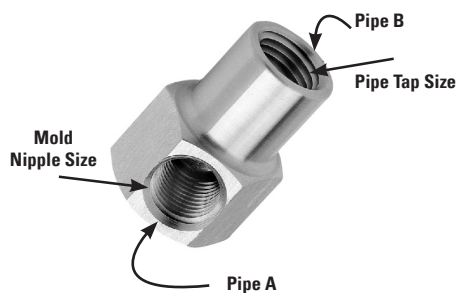

Part Number	Nipple Size	Tap Size (NPT)	Hex Size	L	E	Wrench Clearance "D"
16S	1/16	1/16	9/16	13/16	7/32	1
18S	1/8	1/8	3/4	1	9/32	1 1/4
1814S	1/8	1/4	3/4	1 1/4	9/32	1 1/4
14S	1/4	1/4	7/8	1 3/8	11/32	1 3/8
1438S	1/4	3/8	7/8	1 3/8	11/32	1 3/8
38S	3/8	3/8	1	1 5/8	1/2	1 1/2
50S	1/2	1/2	1 1/4	1 7/8	9/16	1 7/8
75S	3/4	3/4	1 1/2	2 1/4	5/8	2 1/4





# HexKey Extension Elbows

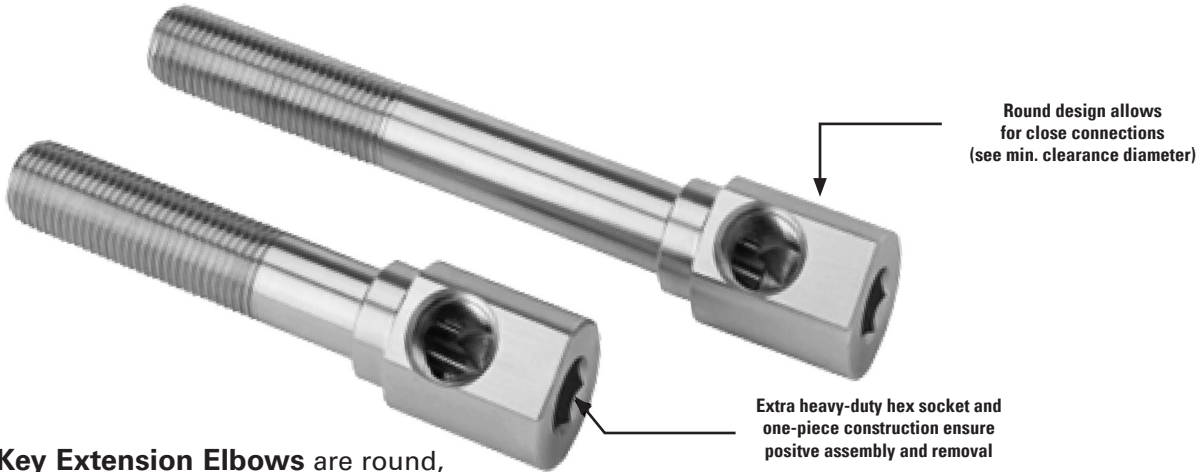

**HexKey Extension Elbows** are round, and install with an Allen wrench. Wrench clearance ideal for use inside the mold, or anywhere space is limited.

- Angular flow path allows connecting pipe fittings to be torqued tight without choking off flow
- Accurate length adjustments are easy with the patented custom mold thread system

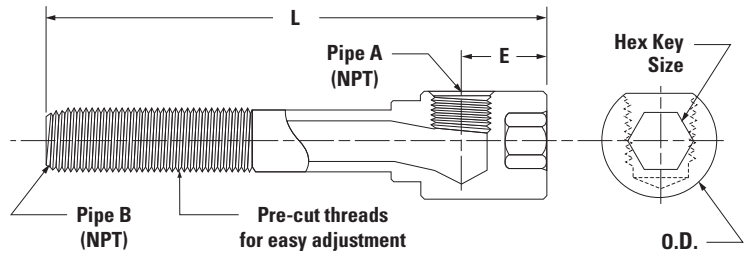

## HEXKEY EXTENSION ELBOWS

Part Number								Pipe Size A	Pipe Size B	E	O.D.	Min. Clearance Dia.	Hex Key Size
Overall Length "L"													
2½"	4"	5½"	7"	8½"	10"	11½"	13"						
EKL16-212	EKL16-4	EKL16-512	EKL16-7	EKL16-812	EKL16-10	EKL16-1112	EKL16-13	⅙	⅙	.531	.552	⅜	¼
EKL18-212	EKL18-4	EKL18-512	EKL18-7	EKL18-812	EKL18-10	EKL18-1112	EKL18-13	⅛	⅛	.580	.615	⅝	⅝
EKL14-212	EKL14-4	EKL14-512	EKL14-7	EKL14-812	EKL14-10	EKL14-1112	EKL14-13	¼	¼	.660	.860	⅞	⅜
EKL38-212	EKL38-4	EKL38-512	EKL38-7	EKL38-812	EKL38-10	EKL38-1112	EKL38-13	⅜	⅜	.780	.985	1	½
EKL50-212	EKL50-4	EKL50-512	EKL50-7	EKL50-812	EKL50-10	EKL50-1112	EKL50-13	½	½	.940	1.235	⅞	½

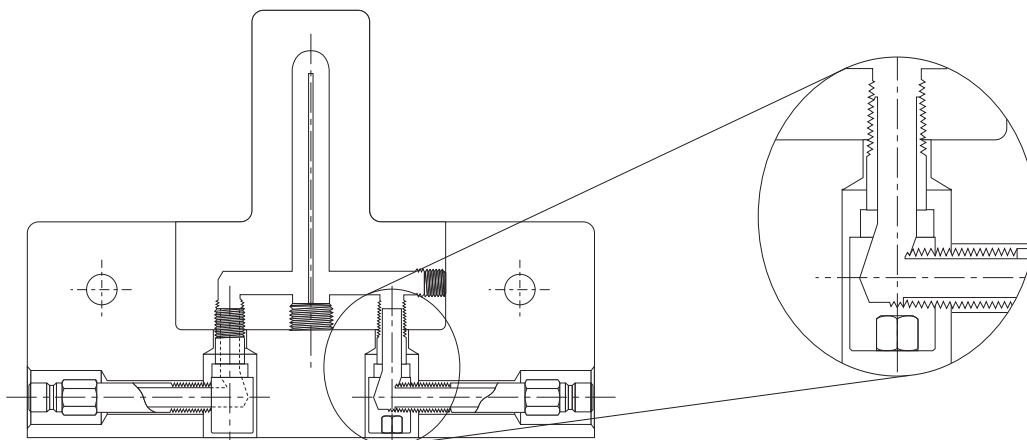

# HexKey Extension Pipes

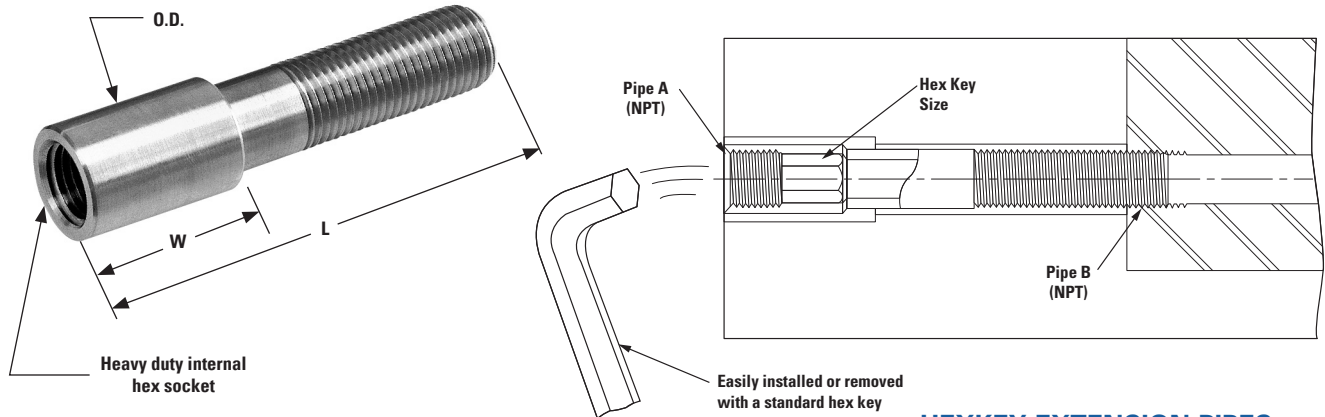

## HEXKEY EXTENSION PIPES

- **HexKey Extension Pipes** are available in a wide variety of special lengths and threads
- Accurate length adjustments are easy with the custom mold adjustable thread system

Part Number Overall Length "L"					Pipe Size A	Pipe Size B	W	O.D.	Hex Key Size
2 1/2"	4"	5 1/2"	7"	8 1/2"					
EP18-212	EP18-4	EP18-512	EP18-7	EP18-812	1/8	1/8	3/4	1/2	1/4
EP14-212	EP14-4	EP14-512	EP14-7	EP14-812	1/4	1/4	1	11/16	3/8
EP38-212	EP38-4	EP38-512	EP38-7	EP38-812	3/8	3/8	1 1/4	13/16	1/2
EP50-212	EP50-4	EP50-512	EP50-7	EP50-812	1/2	1/2	1 1/2	1	9/16

# Piston Tubes



- Precision brazed assembly provides high strength and reliable performance
- Flow-thru pipe plug available in brass, steel or stainless steel

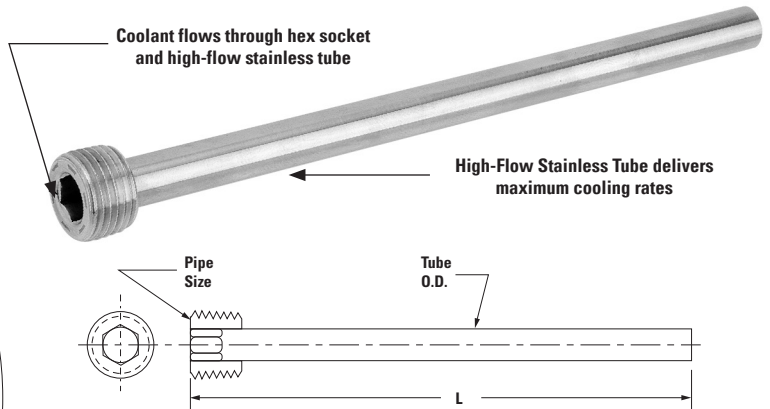
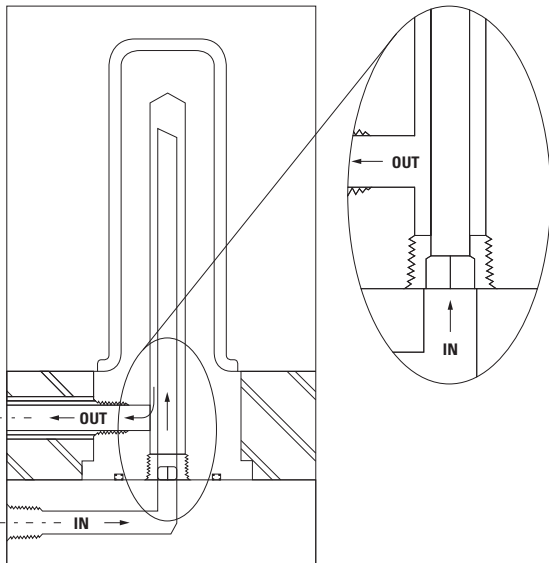

## PISTON TUBES

Part Number Overall Length "L"				Pipe Size (NPT)	Tube O.D.	Tube I.D.
12"	24"	36"	48"			
PT16-12	PT16-24	PT16-36	PT16-48	1/16	.125	.109
PT18-12	PT18-24	PT18-36	PT18-48	1/8	.187	.167
PT14-12	PT14-24	PT14-36	PT14-48	1/4	.250	.230
PT38-12	PT38-24	PT38-36	PT38-48	3/8	.375	.345
PT12-12	PT12-24	PT12-36	PT12-48	1/2	.375	.345
PT34-12	PT34-24	PT34-36	PT34-48	3/4	.437	.407



# Piston Tubes

Part Number	Description
PT12-375-18	PISTON TUBE 1/2" NPT 0.365 OD 0.340 ID 18" OAL
PT12-437-18	PISTON TUBE 1/2" NPT 0.427 OD 0.397 ID 18" OAL
PT14-312-48	PISTON TUBE 1/4" NPT 0.187 OD 0.167 ID 48" OAL
PT16-072-12	PISTON TUBE 1/16 NPT 0.072 OD 0.060 ID 12
PT16-072-18	PISTON TUBE 1/16 NPT 0.072 OD 0.060 ID 18
PT38-437-18	PISTON TUBE 3/8" NPT 0.427 OD 0.397 ID 18" OAL
PT12-375-18	PISTON TUBE 1/2" NPT 0.365 OD 0.340 ID 18" OAL
PT12-437-12	PISTON TUBE 1/2" NPT 0.427 OD 0.397 ID 12" OAL
PT12-437-12	PISTON TUBE 1/2" NPT 0.427 OD 0.397 ID 12" OAL
PT12-437-24	PISTON TUBE 1/2" NPT 0.427 OD 0.397 ID 24" OAL
PT12-437-36	PISTON TUBE 1/2" NPT 0.427 OD 0.397 ID 36" OAL
PT12-437-48	PISTON TUBE 1/2" NPT 0.427 OD 0.397 ID 48" OAL
PT12-500-12	PISTON TUBE 1/2" NPT 0.500 OD 0.444 ID 12" OAL
PT12-500-18	PISTON TUBE 1/2" NPT 0.500 OD 0.444 ID 18" OAL
PT12-500-24	PISTON TUBE 1/2" NPT 0.500 OD 0.444 ID 24" OAL
PT12-500-36	PISTON TUBE 1/2" NPT 0.500 OD 0.444 ID 36" OAL
PT12-500-48	PISTON TUBE 1/2" NPT 0.500 OD 0.444 ID 48" OAL
PT14-187-12	PISTON TUBE 1/4" NPT 0.187 OD 0.167 ID 12" OAL
PT14-187-18	PISTON TUBE 1/4" NPT 0.187 OD 0.167 ID 18" OAL
PT14-187-24	PISTON TUBE 1/4" NPT 0.187 OD 0.167 ID 24" OAL
PT14-187-36	PISTON TUBE 1/4" NPT 0.187 OD 0.167 ID 36" OAL
PT14-187-48	PISTON TUBE 1/4" NPT 0.187 OD 0.167 ID 48" OAL
PT14-250-18	PISTON TUBE 1/4" NPT 0.250 OD 0.230 ID 18" OAL
PT14-312-12	PISTON TUBE 1/4" NPT 0.312 OD 0.288 ID 12" OAL
PT14-312-18	PISTON TUBE 1/4" NPT 0.187 OD 0.167 ID 18" OAL
PT14-312-24	PISTON TUBE 1/4" NPT 0.312 OD 0.288 ID 24" OAL
PT14-312-36	PISTON TUBE 1/4" NPT 0.312 OD 0.288 ID 36" OAL
PT16-072-24	PISTON TUBE 1/16 NPT 0.072 OD 0.060 ID 24
PT16-072-36	PISTON TUBE 1/16 NPT 0.072 OD 0.060 ID 36
PT16-072-48	PISTON TUBE 1/16 NPT 0.072 OD 0.060 ID 48
PT16-093-12	PISTON TUBE 1/16 NPT 0.090 OD 0.076 ID 12
PT16-093-18	PISTON TUBE 1/16 NPT 0.090 OD 0.076 ID 18
PT16-093-24	PISTON TUBE 1/16 NPT 0.090 OD 0.076 ID 24
PT16-093-36	PISTON TUBE 1/16 NPT 0.090 OD 0.076 ID 36
PT16-093-48	PISTON TUBE 1/16 NPT 0.090 OD 0.076 ID 48
PT16-109-12	PISTON TUBE 1/16 NPT 0.109 OD 0.095 ID 12
PT16-109-18	PISTON TUBE 1/16 NPT 0.109 OD 0.095 ID 18
PT16-109-24	PISTON TUBE 1/16 NPT 0.109 OD 0.095 ID 24

Part Number	Description
PT16-109-36	PISTON TUBE 1/16 NPT 0.109 OD 0.095 ID 36
PT16-109-48	PISTON TUBE 1/16 NPT 0.109 OD 0.095 ID 48
PT16-125-18	PISTON TUBE 1/16 NPT 0.125 OD 0.109 ID 18
PT16-187-12	PISTON TUBE 1/16 NPT 0.187 OD 0.167 ID 12
PT16-187-18	PISTON TUBE 1/16 NPT 0.187 OD 0.167 ID 18
PT16-187-24	PISTON TUBE 1/16 NPT 0.187 OD 0.167 ID 24
PT16-187-36	PISTON TUBE 1/16 NPT 0.187 OD 0.167 ID 36
PT16-187-48	PISTON TUBE 1/16 NPT 0.187 OD 0.167 ID 48
PT18-125-12	PISTON TUBE 1/8" NPT 0.125 OD 0.109 ID 12" OAL
PT18-125-18	PISTON TUBE 1/8" NPT 0.125 OD 0.109 ID 18" OAL
PT18-125-24	PISTON TUBE 1/8" NPT 0.125 OD 0.109 ID 24" OAL
PT18-125-36	PISTON TUBE 1/8" NPT 0.125 OD 0.109 ID 36" OAL
PT18-125-48	PISTON TUBE 1/8" NPT 0.125 OD 0.109 ID 48" OAL
PT18-187-18	PISTON TUBE 1/8" NPT 0.187 OD 0.167 ID 18" OAL
PT18-250-12	PISTON TUBE 1/8" NPT 0.250 OD 0.230 ID 12" OAL
PT18-250-18	PISTON TUBE 1/8" NPT 0.250 OD 0.230 ID 18" OAL
PT18-250-24	PISTON TUBE 1/8" NPT 0.250 OD 0.230 ID 24" OAL
PT18-250-36	PISTON TUBE 1/8" NPT 0.250 OD 0.230 ID 36" OAL
PT18-250-48	PISTON TUBE 1/8" NPT 0.250 OD 0.230 ID 48" OAL
PT34-437-18	PISTON TUBE 3/4" NPT 0.427 OD 0.397 ID 18" OAL
PT34-500-12	PISTON TUBE 3/4" NPT 0.500 OD 0.444 ID 12" OAL
PT34-500-18	PISTON TUBE 3/4" NPT 0.500 OD 0.444 ID 18" OAL
PT34-500-24	PISTON TUBE 3/4" NPT 0.500 OD 0.444 ID 24" OAL
PT34-500-36	PISTON TUBE 3/4" NPT 0.500 OD 0.444 ID 36" OAL
PT34-500-48	PISTON TUBE 3/4" NPT 0.500 OD 0.444 ID 48" OAL
PT34-625-12	PISTON TUBE 3/4" NPT 0.625 OD 0.569 ID 12" OAL
PT34-625-18	PISTON TUBE 3/4" NPT 0.625 OD 0.569 ID 18" OAL
PT34-625-24	PISTON TUBE 3/4" NPT 0.625 OD 0.569 ID 24" OAL
PT34-625-36	PISTON TUBE 3/4" NPT 0.625 OD 0.569 ID 36" OAL
PT34-625-48	PISTON TUBE 3/4" NPT 0.625 OD 0.569 ID 48" OAL
PT38-312-12	PISTON TUBE 3/8" NPT 0.312 OD 0.288 ID 12" OAL
PT38-312-18	PISTON TUBE 3/8" NPT 0.312 OD 0.288 ID 18" OAL
PT38-312-24	PISTON TUBE 3/8" NPT 0.312 OD 0.288 ID 24" OAL
PT38-312-36	PISTON TUBE 3/8" NPT 0.312 OD 0.288 ID 36" OAL
PT38-312-48	PISTON TUBE 3/8" NPT 0.312 OD 0.288 ID 48" OAL
PT38-375-18	PISTON TUBE 3/8" NPT 0.365 OD 0.340 ID 18" OAL
PT38-437-12	PISTON TUBE 3/8" NPT 0.427 OD 0.397 ID 12" OAL
PT38-437-24	PISTON TUBE 3/8" NPT 0.427 OD 0.397 ID 24" OAL
PT38-437-36	PISTON TUBE 3/8" NPT 0.427 OD 0.397 ID 36" OAL
PT38-437-48	PISTON TUBE 3/8" NPT 0.427 OD 0.397 ID 48" OAL





# Straight Blade Plug Baffles

## STRAIGHT BLADE PLUG BAFFLES

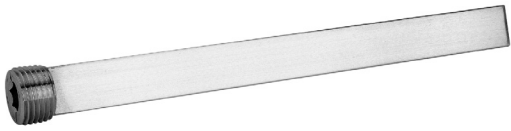

- Flush-seal type ( $7/8$  taper) brass pipe plugs standard; alloy, stainless, and oversize ( $3/4$  taper) plugs available
- Precision soldered to exacting tolerances to closely fit the cooling channel
- Same day shipment on custom length baffles
- Custom stepped width blades, and plug size combinations quoted on request
- $3/4$ " NPT brass plug baffles for use with  $29/32$ " tap drill are available from stock

Part Number	Plug Size (NPT)	Overall Length	Blade Width	Drill Dia.	Blade Thickness
SB16x4	$1/16$	4"	$1/4$	$1/4$	.050
SB16x8	$1/16$	8"	$1/4$	$1/4$	.050
SB16x12	$1/16$	12"	$1/4$	$1/4$	.050
SB18x4	$1/8$	4"	$5/16$	$5/16$	.050
SB18x8	$1/8$	8"	$5/16$	$5/16$	.050
SB18x12	$1/8$	12"	$5/16$	$5/16$	.050
SB14x5	$1/4$	5"	$7/16$	$7/16$	.080
SB14x10	$1/4$	10"	$7/16$	$7/16$	.080
SB14x15	$1/4$	15"	$7/16$	$7/16$	.080
SB38x6	$3/8$	6"	$9/16$	$9/16$	.090
SB38x12	$3/8$	12"	$9/16$	$9/16$	.090
SB38x18	$3/8$	18"	$9/16$	$9/16$	.090
SB12x8	$1/2$	8"	$11/16$	$11/16$	.090
SB12x16	$1/2$	16"	$11/16$	$11/16$	.090
SB34x12	$3/4$	12"	$15/16$	$15/16$	.090
SB34x20	$3/4$	20"	$15/16$	$15/16$	.090
SB1x16	1	16"	$1 1/8$	$1 1/8$	.105
SB1x24	1	24"	$1 1/8$	$1 1/8$	.105

# Turbo Blade Plug Baffles

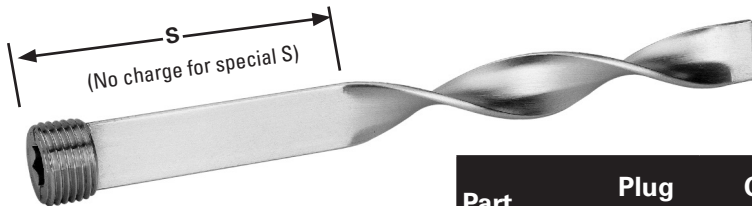

## TURBO BLADE PLUG BAFFLES

- Spiral provides turbulent cooling action and keeps blade centered in waterline for maximum flow rates

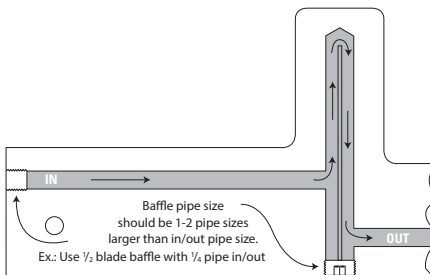

Part Number	Plug Size (NPT)	O Overall Length	Blade S Straight Length	Width (-.005) (-.015)	Drill Dia.	Blade Thickness
TB16x4	$1/16$	4"	2"	$1/4$	$1/4$	.050
TB16x8	$1/16$	8"	4"	$1/4$	$1/4$	.050
TB16x12	$1/16$	12"	6"	$1/4$	$1/4$	.050
TB18x4	$1/8$	4"	2"	$5/16$	$5/16$	.050
TB18x8	$1/8$	8"	4"	$5/16$	$5/16$	.050
TB18x12	$1/8$	12"	6"	$5/16$	$5/16$	.050
TB14x5	$1/4$	5"	2"	$7/16$	$7/16$	.080
TB14x10	$1/4$	10"	4"	$7/16$	$7/16$	.080
TB14x15	$1/4$	15"	6"	$7/16$	$7/16$	.080
TB38x6	$3/8$	6"	2"	$9/16$	$9/16$	.090
TB38x12	$3/8$	12"	4"	$9/16$	$9/16$	.090
TB38x18	$3/8$	18"	6"	$9/16$	$9/16$	.090
TB12x8	$1/2$	8"	3"	$11/16$	$11/16$	.090
TB12x16	$1/2$	16"	5"	$11/16$	$11/16$	.090
TB34x12	$3/4$	12"	4"	$15/16$	$15/16$	.090
TB34x20	$3/4$	20"	6"	$15/16$	$15/16$	.090
TB1x16	1	16"	5"	$1 1/8$	$1 1/8$	.105
TB1x24	1	24"	8"	$1 1/8$	$1 1/8$	.105

# Adjustable Hex Nipple

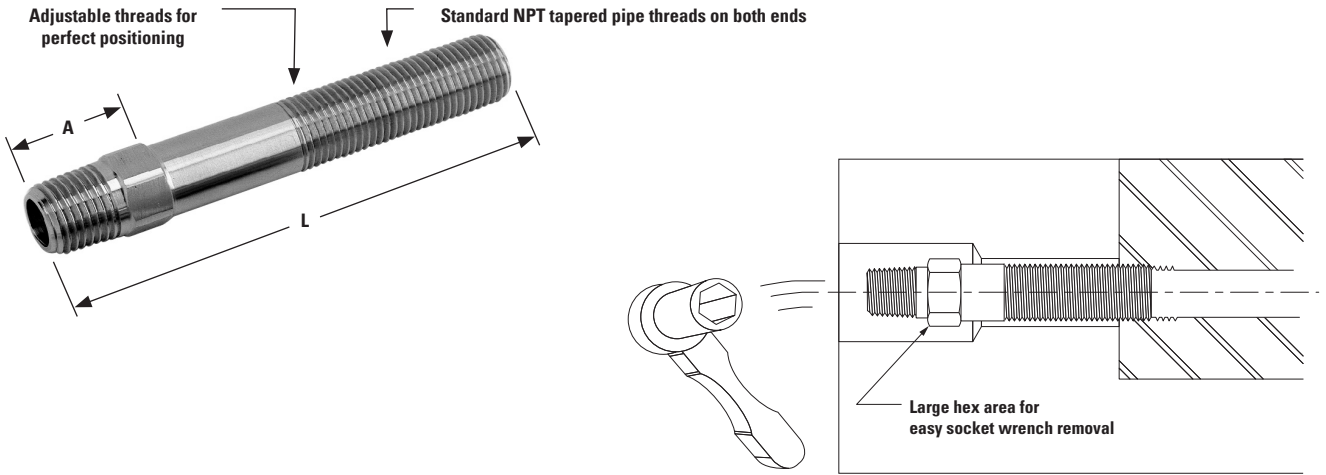

- Especially useful when installing Cascade Heads, Hex Elbows, etc. inside molds and slides
- Longer or special exact lengths available
- Also available in special thread combinations (including BSP)

## ADJUSTABLE HEX NIPPLE

Part Number								Pipe Size (NPT)	A	Hex Size
Overall Length "L"										
2½"	4"	5½"	7"	8½"	10"	11½"	13"			
APN16-212	APN16-4	APN16-512	APN16-7	APN16-812	APN16-10	APN16-1112	APN16-13	1/16	11/16	3/8
APN18-212	APN18-4	APN18-512	APN18-7	APN18-812	APN18-10	APN18-1112	APN18-13	1/8	3/4	7/16
APN14-212	APN14-4	APN14-512	APN14-7	APN14-812	APN14-10	APN14-1112	APN14-13	1/4	7/8	9/16
APN38-212	APN38-4	APN38-512	APN38-7	APN38-812	APN38-10	APN38-1112	APN38-13	3/8	1	11/16
APN12-212	APN12-4	APN12-512	APN12-7	APN12-812	APN12-10	APN12-1112	APN12-13	1/2	1 3/8	7/8

E





# Pressure Plugs-Threaded

## Threaded

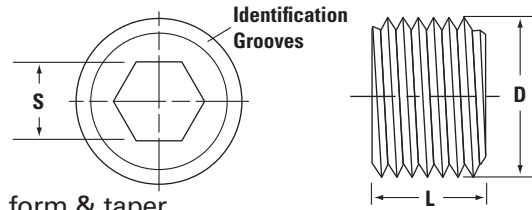

- 7/8 taper for flush installation – closely controlled thread size, form & taper
- High-pressure seal is developed through a deliberate difference in taper between plug & tapped hole
- Steel is high-grade alloy type heat treated to Rc 35-40

### PRESSURE PLUGS THREADED

Brass 7/8 Taper				Steel 7/8 Taper			
Size	Part Number	S-Key Size	Tap Drill	L-Body Length	Threads Per Inch	Size	Part Number
1/16"	BP1	5/32	15/64	.250	27	1/16"	SP1M
1/8"	BP2	3/16	21/64	.250	27	1/8"	SP2
1/4"	BP4	1/4	27/64	.406	18	1/4"	SP4
3/8"	BP6	5/16	9/16	.406	18	3/8"	SP6M
1/2"	BP8	3/8	11/16	.531	14	1/2"	SP8M
3/4"	BP12	9/16	57/64	.531	14	3/4"	SP12M
1"	BP16	5/8	1-1/8	.656	11-1/2	1"	SP16M
1-1/4"	BP20M	3/4	1-15/32	.656	11-1/2		
1-1/2"	BP24	1	1-25/32	.656	11-1/2		

## Pressure Plugs - Threadless

Brass threadless plugs have a time-saving expandable O-ring design. When the plug's socket head screw is tightened, the O-ring expands to provide a positive seal. No tapping necessary; easy installation and removal. Perfect solution for limited space situations.

- Seals rough and corroded holes
- No tapping needed
- Withstands pressures up to 72 PSI

Part Number	Hex Nominal Size	Drill Length L	Size S	Size D	O-Rings Pkg. Of 10
BTP2	1/8"	.50	5/64	11/32	BTO2
BTP2OS	1/8"+	.50	5/64	23/64	BTO2
BTP4	1/4"	.56	1/8	7/16	BTO4
BTP4OS	1/4"+	.56	1/8	29/64	BTO4
BTP6	3/8"	.62	1/8	9/16	BTO6
BTP6OS	3/8"+	.62	1/8	37/64	BTO6
BTP8	1/2"	.62	1/8	11/16	BTO8
BTP8OS	1/2"+	.62	1/8	45/64	BTO8



### PRESSURE PLUGS THREADLESS

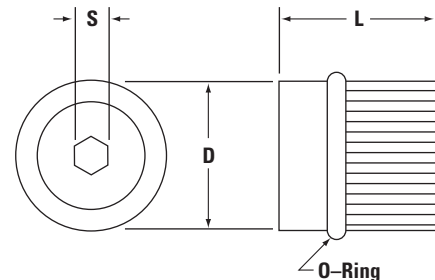

## 9 Pc. Folding Hex Key Set



- Chrome vanadium steel
- Hardened and tempered for strength
- Plated handle
- Black oxide finish
- Sizes: 0.050", 5/64", 7/64", 9/64", 3/16", 1/16", 3/32", 1/8", 5/32"

Part Number HEK9C

# Brass Pipe Nipples



## BRASS PIPE NIPPLES

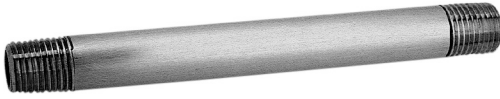

Brass Long Nipples	
Part Number	Pipe Size × Length
<b>1/16</b>	
BNL110	1/16 × 1
BNL115	1/16 1 1/2
BNL120	1/16 2
BNL125	1/16 2 1/2
BNL130	1/16 3
BNL140	1/16 4
BNL160	1/16 6
BNL180	1/16 8
BNL1100	1/16 10
BNL1200	1/16 12
<b>1/8</b>	
BNL215	1/8 × 1 1/2
BNL220	1/8 2
BNL225	1/8 2 1/2
BNL230	1/8 3
BNL235	1/8 3 1/2
BNL240	1/8 4
BNL250	1/8 5
BNL260	1/8 6
BNL280	1/8 8
BNL2100	1/8 10
BNL2120	1/8 12
<b>1/4</b>	
BNL415	1/4 1 1/2
BNL420	1/4 2
BNL425	1/4 2 1/2
BNL430	1/4 3
BNL435	1/4 3 1/2
BNL440	1/4 4
BNL445	1/4 4 1/2
BNL450	1/4 5
BNL460	1/4 6
BNL480	1/4 8
BNL4100	1/4 10
BNL4120	1/4 12

Brass Long Nipples	
Part Number	NPT Size
<b>3/8</b>	
BNL615	3/8 × 1 1/2
BNL620	3/8 × 2
BNL625	3/8 × 2 1/2
BNL630	3/8 × 3
BNL635	3/8 × 3 1/2
BNL640	3/8 × 4
BNL660	3/8 × 6
BNL680	3/8 × 8
<b>1/2</b>	
BNL815	1/2 × 1 1/2
BNL820	1/2 × 2
BNL825	1/2 × 2 1/2
BNL830	1/2 × 3
BNL835	1/2 × 3 1/2
BNL840	1/2 × 4
BNL860	1/2 × 6
BNL880	1/2 × 8
<b>3/4</b>	
BNL1215	3/4 × 1 1/2
BNL1220	3/4 × 2
BNL1225	3/4 × 2 1/2
BNL1230	3/4 × 3
BNL1235	3/4 × 3 1/2
<b>1</b>	
BNL1620	1 × 2
BNL1625	1 × 2 1/2
BNL1630	1 × 3
BNL1635	1 × 3 1/2

Brass Close Nipples	
Part Number	NPT Size
BNS2	1/8"
BNS4	1/4"
BNS6	3/8"
BNS8	1/2"
BNS12	3/4"
BNS16	1"
BNS20	1 1/4"
BNS24	1 1/2"





# Brass Pipe Adapters

## BRASS PIPE NIPPLES

### Brass Pipe Bushings

Part Number	NPT Sizes
BPB2-1	1/8 x 1/16
BPB4-2	1/4 x 1/8
BPB6-2	3/8 x 1/8
BPB6-4	3/8 x 1/4
BPB8-2	1/2 x 1/8
BPB8-4	1/2 x 1/4
BPB8-6	1/2 x 3/8
BPB12-2	3/4 x 1/8
BPB12-4	3/4 x 1/4
BPB12-6	3/4 x 3/8
BPB12-8	3/4 x 1/2
BPB16-4	1 x 1/4
BPB16-6	1 x 3/8
BPB16-8	1 x 1/2
BPB16-12	1 x 3/4
BPB20-8*	1 1/4 x 1/2
BPB20-12*	1 1/4 x 3/4
BPB20-16*	1 1/4 x 1
BPB24-8*	1 1/2 x 1/2
BPB24-12*	1 1/2 x 3/4
BPB24-16*	1 1/2 x 1
BPB24-20*	1 1/2 x 1 1/4

\*Bronze

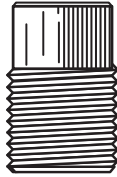
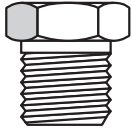
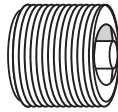
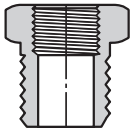

### Brass Street Elbow 90°

Part Number	Size F x M
BE9S2-2	1/8 x 1/16
BE9S2-4	1/8 x 1/4
BE9S4-2	1/4 x 1/8
BE9S4-4	1/4 x 1/4
BE9S4-6	1/4 x 3/8
BE9S6-4	3/8 x 1/4
BE9S6-6	3/8 x 3/8
BE9S6-8	3/8 x 1/2
BE9S8-6	1/2 x 3/8
BE9S8-8*	1/2 x 1/2
BE9S12-12*	3/4 x 3/4

\*Bronze

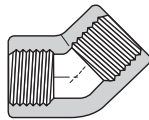
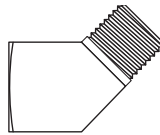
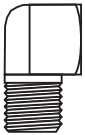

### Brass Elbow 90°

Part Number	NPT Size
BE9-2-2	1/8
BE9-4-4	1/4
BE9-6-6*	3/8
BE9-8-8*	1/2

\*Bronze

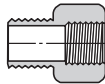
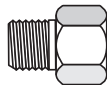
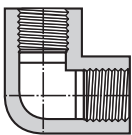

### Brass Allen Plug

Part Number	Size
BAP1	1/16
BAP2	1/8
BAP4	1/4
BAP6	3/8
BAP8	1/2
BAP12	3/4

Please see Pressure Plugs for 7/8 taper mold plugs

### Brass Square Plugs

Part Number	NPT Size
BSP2	1/8
BSP4	1/4
BSP6	3/8
BSP8	1/2
BSP12	3/4
BSP16*	1
BSP20*	1 1/4
BSP24*	1 1/2

\*Bronze

### Brass Street Elbow 45°

Part Number	NPT Size
BE4S2-2	1/8
BE4S4-4	1/4
BE4S6-6	3/8
BE4S8-8	1/2

### Brass Elbow 45°

Part Number	NPT Size
BE4-2	1/8
BE4-4	1/4
BE4-6*	3/8
BE4-8*	1/2

\*Bronze

### Brass Female x Male

Part Number	Size F x M
BMF2-2	1/8 x 1/8
BMF4-2	1/4 x 1/8
BMF4-4	1/4 x 1/4
BMF6-2	3/8 x 1/8
BMF6-4	3/8 x 1/4
BMF6-6	3/8 x 3/8
BMF8-4	1/2 x 1/4
BMF8-6	1/2 x 3/8
BMF8-8	1/2 x 1/2

# Brass Pipe Adapters

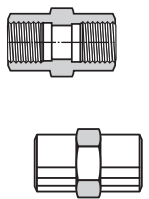

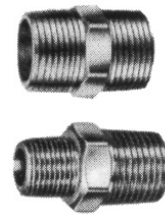

Brass Pipe Coupling	
Part Number	Size
BPC2-2	1/8" x 1/8"
BPC4-2	1/4" x 1/8"
BPC4-4	1/4" x 1/4"
BPC6-2	3/8" x 1/8"
BPC6-4	3/8" x 1/4"
BPC6-6	3/8" x 3/8"
BPC8-4	1/2" x 1/4"
BPC8-6	1/2" x 3/8"
BPC8-8	1/2" x 1/2"
BPC12-8	3/4" x 1/2"
BPC12-12	3/4" x 3/4"

## PIPE ADAPTERS

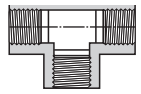

Brass Hex Nipple	
Part Number	Size
BHN2-1	1/8" x 1/16"
BHN2-2	1/8" x 1/8"
BHN4-2	1/4" x 1/8"
BHN4-4	1/4" x 1/4"
BHN6-2	3/8" x 1/8"
BHN6-4	3/8" x 1/4"
BHN6-6	3/8" x 3/8"
BHN8-4	1/2" x 1/4"
BHN8-6	1/2" x 3/8"
BHN8-8	1/2" x 1/2"
BHN12-12	3/4" x 3/4"



Brass Pipe Tee	
Part Number	Size
BPT2-2	1/8" x 1/8"
BPT4-4	1/4" x 1/4"
BPT6-6	3/8" x 3/8"
BPT8-8	1/2" x 1/2"

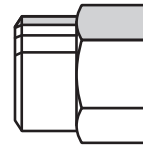

Brass Pipe Cap	
Part Number	Size
BPCA2-2	1/8" x 1/8"
BPCA4-4	1/4" x 1/4"
BPCA6-6	3/8" x 3/8"
BPCA8-8	1/2" x 1/2"

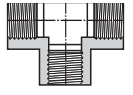

Brass Branch Tee	
Part Number	Size
BBT2-2	1/8" x 1/8"
BBT4-4	1/4" x 1/4"
BBT6-6	3/8" x 3/8"



# Thread Sealing Tape



- Permanent non-flammable seal
- Remains plastic permanently
- -450°F to +500°F
- Perfect for water connections, hydraulics, air, gas, petroleum
- The finest quality PTFE tape available
- NEVER use thinner, cheaper substitutes

## THREAD SEALING TAPE

Part Number	Length	Thickness	Width
TT100	260" (21.6')	0.0035	1/2"
TT200	520" (43.3')	0.0035	1/2"
TT300	520" (43.3')	0.0035	3/4"



# Standard Hose Barbs

## STANDARD HOSE BARBS

Male Hose Barbs		
Part Number	Hose I. D.	Pipe Thread
205-4-2	1/4	1/8
205-4-4	1/4	1/4
205-4-6	1/4	3/8
205-5-2	5/16	1/8
205-5-4	5/16	1/4
205-6-2	3/8	1/8
205-6-4	3/8	1/4
205-6-6	3/8	3/8
205-6-8	3/8	1/2
205-8-4	1/2	1/4
205-8-6	1/2	3/8
205-8-8	1/2	1/2
205-8-12	1/2	3/4
205-10-8	5/8	1/2
205-10-12	5/8	3/4
205-12-8	3/4	1/2
205-12-12	3/4	3/4
205-16-12	1	3/4
205-16-16	1	1
205-20-16	1 1/4	1



Male Swivel Hose Barbs		
Part Number	Hose I. D.	Pipe Thread
215-4-4	1/4	1/4
215-6-4	3/8	1/4
215-6-6	3/8	3/8
215-8-8	1/2	1/2
215-12-12	3/4	3/4



Hose Mender Barbs	
Part Number	Hose I. D.
250-4-4	1/4
250-5-5	5/16
250-6-6	3/8
250-8-8	1/2
250-10-10	5/8
250-12-12	3/4



Male Hose Barbs - 90°		
Part Number	Hose I. D.	Pipe Thread
209-4-2	1/4	1/8
209-4-4	1/4	1/4
209-6-4	3/8	1/4
209-6-6	3/8	3/8
209-8-6	1/2	3/8
209-8-8	1/2	1/2



Female 37° Swivel Hose Barbs		
Part Number	Hose I. D.	Flare Size
237-4-4	1/4	1/4
237-4-6	1/4	3/8
237-6-6	3/8	3/8
237-6-8	3/8	1/2
237-8-8	1/2	1/2
237-8-10	1/2	5/8



Female 45° Swivel Hose Barbs		
Part Number	Hose I. D.	Flare Size
245-4-4	1/4	1/4
245-4-6	1/4	3/8
245-6-6	3/8	3/8
245-6-8	3/8	1/2
245-8-8	1/2	1/2
245-8-10	1/2	5/8



Female Ball Seat Hose Barbs		
Part Number	Hose I. D.	Pipe Thread
220-4-4	1/4	1/4
220-6-4	3/8	1/4
220-6-6	3/8	3/8

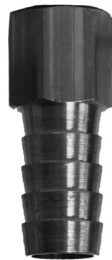

Rigid Female Hose Barbs		
Part Number	Hose I. D.	Pipe Thread
210-4-2	1/4	1/8
210-4-4	1/4	1/4
210-6-4	3/8	1/4
210-6-6	3/8	3/8
210-8-4	1/2	1/4
210-8-6	1/2	3/8
210-8-8	1/2	1/2

## Steel Constructed

Male King Nipples		
Part Number	Hose I. D.	Pipe Thread
206-8-8	1/2	1/2
206-12-12	3/4	3/4
206-12-16	3/4	1
206-16-16	1	1
206-16-20	1	1 1/4
206-20-20	1 1/4	1 1/4
206-24-24	1 1/2	1 1/2
206-32-32	2	2



# Brass Push-On Hose Barbs



## BRASS PUSH ON HOSE BARBS

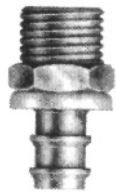

### Male Push-On

Part Number	Hose I. D.	Pipe Thread
305-4-2	1/4	1/8
305-4-4	1/4	1/4
305-4-6	1/4	3/8
305-6-2	3/8	1/8
305-6-4	3/8	1/4
305-6-6	3/8	3/8
305-6-8	3/8	1/2
305-8-4	1/2	1/4
305-8-6	1/2	3/8
305-8-8	1/2	1/2
305-10-8	5/8	1/2
305-10-12	5/8	3/4
305-12-8	3/4	1/2
305-12-12	3/4	3/4



### Female 37° Swivel Push-On

Part Number	Hose I. D.	Flare Size
337-4-4	1/4	1/4
337-4-6	1/4	3/8
337-6-6	3/8	3/8
337-6-8	3/8	1/2
337-8-8	1/2	1/2
337-8-10	1/2	5/8
337-10-10	5/8	5/8
337-12-12	3/4	3/4

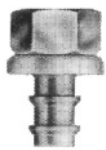

### Rigid Female Pipe Push-On

Part Number	Hose I. D.	Pipe Thread
310-4-2	1/4	1/8
310-4-4	1/4	1/4
310-6-4	3/8	1/4
310-6-6	3/8	3/8
310-8-6	1/2	3/8
310-8-8	1/2	1/2



### Female 45° Swivel Push-On

Part Number	Hose I. D.	Flare Size
345-4-4	1/4	1/4
345-4-6	1/4	3/8
345-6-6	3/8	3/8
345-6-8	3/8	1/2
345-8-6	1/2	3/8
345-8-8	1/2	1/2
345-8-10	1/2	5/8
345-10-8	5/8	1/2
345-10-10	5/8	5/8
345-12-12	3/4	3/4



### Male Pipe Swivel Push-On

Part Number	Hose I. D.	Pipe Thread
315-4-4	1/4	1/4
315-6-4	3/8	1/4
315-6-6	3/8	3/8
315-8-8	1/2	1/2
315-12-12	3/4	3/4



### Female Pipe Swivel

Part Number	Hose I. D.	Flare Size
325-4-2	1/4	1/8
325-4-4	1/4	1/4
325-6-4	3/8	1/4
325-6-6	3/8	3/8
325-8-8	1/2	1/2

Use Genuine Oetiker Hose Clamps with these Beaded Hose Barbs!  
P. 484



### Hose Mender Push-On

Part Number	Hose I. D.
350-4-4	1/4
350-6-6	3/8
350-8-8	1/2
350-10-10	5/8
350-12-12	3/4

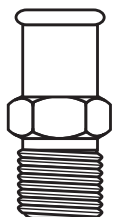

### Brass Beaded Hose Barbs

Part Number	Hose I. D.	Pipe Thread	Part Number	Hose I. D.	Pipe Thread
208-4-2	1/4	1/8	208-8-6	1/2	3/8
208-4-4	1/4	1/4	208-8-8	1/2	1/2
208-6-2	3/8	1/8	208-10-8	5/8	1/2
208-6-4	3/8	1/4	208-12-12	3/4	3/4
208-6-6	3/8	3/8			





# 45° Brass Pipe Adapters

## PIPE ADAPTERS (ALL)

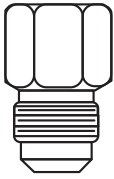

Male Flare x Female Pipe			
Part Number	Flare Size	Pipe Thread	
346-4-2	1/4	1/8	
346-4-4	1/4	1/4	
346-6-2	3/8	1/8	
346-6-4	3/8	1/4	
346-6-6	3/8	3/8	
346-8-6	1/2	3/8	
346-8-8	1/2	1/2	

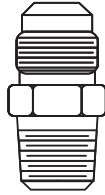

Flare x Pipe		
Part Number	Flare Size	Pipe Thread
348-2-2	1/8	1/8
348-4-2	1/4	1/8
348-4-4	1/4	1/4
348-4-6	1/4	3/8
348-6-2	3/8	1/8
348-6-4	3/8	1/4
348-6-6	3/8	3/8
348-6-8	3/8	1/2
348-8-6	1/2	3/8
348-8-8	1/2	1/2
348-10-8	5/8	1/2
348-10-12	5/8	3/4
348-12-12	3/4	3/4



Flare x Pipe - 90°		
Part Number	Flare Size	Pipe Thread
349-4-2	1/4	1/8
349-4-4	1/4	1/4
349-6-2	3/8	1/8
349-6-4	3/8	1/4
349-6-6	3/8	3/8
349-8-6	1/2	3/8
349-8-8	1/2	1/2
349-10-8	5/8	1/2
349-12-12	3/4	3/4

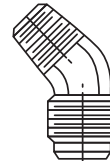

Flare x Pipe - 45°		
Part Number	Flare Size	Pipe Thread
347-4-2	1/4	1/8
347-4-4	1/4	1/4
347-6-4	3/8	1/4
347-6-6	3/8	3/8
347-8-6	1/2	3/8
347-8-8	1/2	1/2

# 37° Steel Pipe Adapters

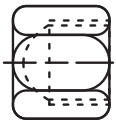

Cap Nut		
Part Number	Das Size	Flare Size
820-4	1/4	7/16-20
820-6	3/8	9/16-18
820-8	1/2	3/4-16

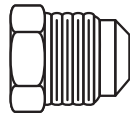

Plug		
Part Number	Das Size	Flare Size
821-4	1/4	7/16-20
821-6	3/8	9/16-18
821-8	1/2	3/4-16

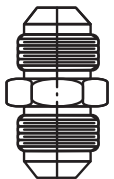

Union		
Part Number	Das Size	Flare Size
824-4	1/4	7/16-20
824-6	3/8	9/16-18
824-8	1/2	3/4-16

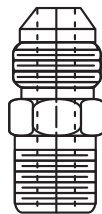

Flare x Pipe		
Part Number	Flare Size	Pipe Thread
816-4-2	1/4	1/8
816-4-4	1/4	1/4
816-6-4	3/8	1/4
816-6-6	3/8	3/8
816-8-6	1/2	3/8
816-8-8	1/2	1/2
816-12-12	3/4	3/4

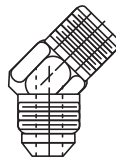

Flare x Pipe - 45°		
Part Number	Flare Size	Pipe Thread
823-4-2	1/4	1/8
823-4-4	1/4	1/4
823-6-4	3/8	1/4
823-6-6	3/8	3/8
823-8-6	1/2	3/8
823-8-8	1/2	1/2
823-12-12	3/4	3/4

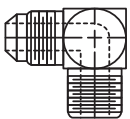

Flare x Pipe - 90°		
Part Number	Flare Size	Pipe Thread
822-4-2	1/4	1/8
822-4-4	1/4	1/4
822-6-4	3/8	1/4
822-6-6	3/8	3/8

Flare x Pipe - 90°		
Part Number	Flare Size	Pipe Thread
822-8-6	1/2	3/8
822-8-8	1/2	1/2
822-10-8	5/8	1/2
822-12-12	3/4	3/4

# Steel Hydraulic Adapters



## HYDRAULIC ADAPTERS (ALL)

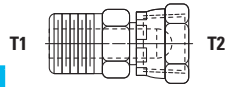

Male Pipe Adapter		
Part Number	T1	T2
708-2-2	1/8"	1/8"
708-2-4	1/8"	1/4"
708-4-4	1/4"	1/4"
708-4-6	1/4"	3/8"
708-6-4	3/8"	1/4"
708-6-6	3/8"	3/8"
708-6-8	3/8"	1/2"
708-8-4	1/2"	1/4"
708-8-6	1/2"	3/8"
708-8-8	1/2"	1/2"
708-12-8	3/4"	1/2"
708-12-12	3/4"	3/4"
708-12-16	3/4"	1"
708-16-12	1"	3/4"
708-16-16	1"	1"

Male Pipe Coupling		
Part Number	T1	T2
751-2-2	1/8"	1/8"
751-4-2	1/4"	1/8"
751-4-4	1/4"	1/4"
751-6-6	3/8"	3/8"
751-8-8	1/2"	1/2"
751-12-12	3/4"	3/4"

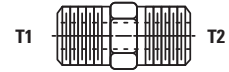

90° Street Elbow		
Part Number	T1	T2
754-2-2	1/8"	1/8"
754-4-2	1/4"	1/8"
754-4-4	1/4"	1/4"
754-6-6	3/8"	3/8"
754-8-8	1/2"	1/2"

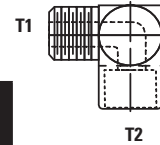

Female Pipe Adapter		
Part Number	T1	T2
709-2-2	1/8"	1/8"
709-4-4	1/4"	1/4"
709-6-6	3/8"	3/8"
709-8-8	1/2"	1/2"
709-12-12	3/4"	3/4"
709-16-16	1"	1"

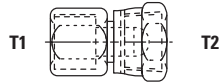

Female Union		
Part Number	T1	T2
750-2-2	1/8"	1/8"
750-4-2	1/4"	1/8"
750-4-4	1/4"	1/4"
750-6-6	3/8"	3/8"
750-8-8	1/2"	1/2"

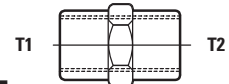

45° Street Elbow		
Part Number	T1	T2
755-2-2	1/8"	1/8"
755-4-4	1/4"	1/4"
755-6-6	3/8"	3/8"
755-8-8	1/2"	1/2"

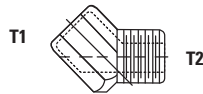

90° Female Pipe		
Part Number	T1	T2
756-2-2	1/8"	1/8"
756-4-4	1/4"	1/4"
756-6-6	3/8"	3/8"
756-8-8	1/2"	1/2"

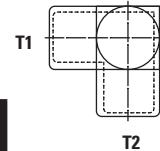

90° Male Pipe		
Part Number	T1	T2
759-2-2	1/4"	1/8"
759-4-4	1/4"	1/4"
759-6-6	3/8"	3/8"
759-8-8	1/2"	1/2"

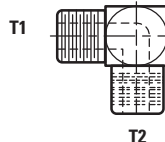



# Push-Lok™ Hose Barbs

Parker®

The very best hose deserves the very best fittings! Parker Push-Lok Fittings are perfectly matched to Parker Push-Lok Hose to ensure a maximum service life. We recommend using only Parker Fittings with Parker Push-Lok Hose.

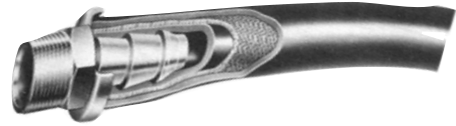

**PUSH-LOK HOSE BARBS**

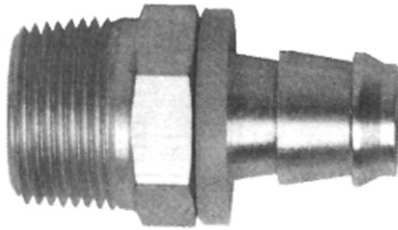

### Male Pipe Thread

Part Number	Hose I. D.	Pipe Thread
30182-2-4B	1/4"	1/8"
30182-4-4B	1/4"	1/4"
30182-4-6B	3/8"	1/4"
30182-6-6B	3/8"	3/8"
30182-8-6B	3/8"	1/2"
30182-6-8B	1/2"	3/8"
30182-8-8B	1/2"	1/2"
30182-12-8B	1/2"	3/4"
30182-8-10B	5/8"	1/2"
30182-12-12B	3/4"	3/4"

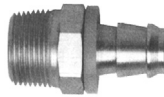

### Male Pipe Swivel

Part Number	Hose I. D.	Pipe Thread
31382-4-4	1/4"	1/4"
31382-6-6	3/8"	3/8"
31382-8-8	1/2"	1/2"

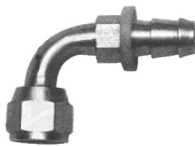

### 90° Female Swivel

Part Number	Hose I. D.	Pipe Thread	Fits Flare
33982-4-4	1/4"	7/16 - 20	37°/45°
33982-6-6	3/8"	9/16 - 18	37°
33982-8-8	1/2"	3/4 - 16	37°/45°

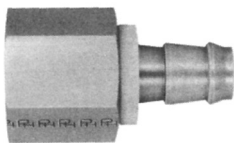

### Female Pipe Swivel

Part Number	Hose I. D.	Pipe Thread
30282-4-4B	1/4"	1/4"
30282-6-6B	3/8"	3/8"
30282-8-8B	1/2"	1/2"

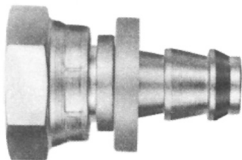

### Female Pipe Ridge

Part Number	Hose I. D.	Pipe Thread
37G82-4-4	1/4"	1/4"
37G82-4-6	3/8"	1/4"
37G82-6-6	3/8"	3/8"
37G82-8-8	1/2"	1/2"
37G82-8-10	5/8"	1/2"
37G82-12-12	3/4"	3/4"



### Hose Menders

Part Number	Hose I. D.
38282-4-4B	1/4"
38282-6-6B	3/8"
38282-8-8B	1/2"

# Helical Thread Inserts



The insert system was devised as a simple method of repairing stripped or damaged threads in any metal or valuable parts. Inserts are also used in die castings and plastics where excessive stress on threads could cause damage or failure. Inserts are helical coils of diamond-shaped 18-8 stainless steel wire which meets or exceeds AMS-7245 specification. Inserts are sized to provide a precisely controlled interference fit in an oversize tapped hole. The tap used for this purpose is the same pitch as the original thread, but has a larger diameter. When the insert is installed, the hole is returned to its original size.

Because the insert provides an enlarged bearing area, the restored fastening is stronger than the original. It is also more durable, since the stainless steel thread is generally tougher than the original material. Inserts are corrosion resistant and their 22 micro-inch or better surface finish provides a smooth-running, wear-resistant fastening.

## Inserts Only – UNC

Thread Size	Part Number	Length
1/4 – 20	RC03043	.375
1/4 – 20	RC03044	.500
3/8 – 16	RC03063	.563
3/8 – 16	RC03064	.750
1/2 – 13	RC03083	.750
1/2 – 13	RC03084	1.000
5/8 – 11	RC03103	.983
5/8 – 11	RC03104	1.250
3/4 – 10	RC03123	1.125
3/4 – 10	RC03124	1.500
1 – 8	RC03163	1.500
1 – 8	RC03164	2.000
1 1/8 – 7	RC03183	2.500
1 1/4 – 7	RC03203	2.500
1 3/8 – 6	RC03223	2.750
1 1/2 – 6	RC03243	3.000

## Simple Installation:

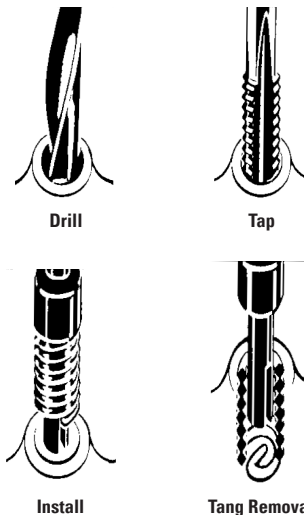

## HELICAL THREAD INSERTS



**CHRISLYNN**  
HELICAL INSERTS  
PRECISION

- 18-8 stainless steel
- Corrosion resistant
- 22 micro-inch or better surface finish provides a smooth running, wear-resistant fastening



## Repair Kits - UNC

Kit includes: Inserts, Tap, Tool and Case

Thread Size	Part Number	Inserts per Kit
4 – 40	RC33540	12
5 – 40	RC33550	12
6 – 32	RC33560	12
8 – 32	RC33580	12
10 – 24	RC33600	12
12 – 24	RC33620	12
1/4 – 20	RC33040	12
5/16 – 18	RC33050	10
3/8 – 16	RC33060	10
7/16 – 14	RC33070	6
1/2 – 13	RC33080	6
9/16 – 12	RC33090	6
5/8 – 11	RC33100	6
3/4 – 10	RC33120	4
7/8 – 9	RC33140	6
1 – 8	RC33160	6
1 1/8 – 7	RC33180	5
1 1/4 – 7	RC33200	4
1 3/8 – 6	RC33220	4
1 1/2 – 6	RC33240	4

Inserts in kits are 1.5 times screw diameter in length.



# Galvanized & Black Pipe Nipples

## GALVANIZED & BLACK PIPE NIPPLES

Close Nipples			
Size	Close Length	Galvanized Part Number	Black Pipe Part Number
1/8"	3/4"	GNS2	BLNS2
1/4"	7/8"	GNS4	BLNS4
3/8"	1"	GNS6	BLNS6
1/2"	1 1/8"	GNS8	BLNS8
3/4"	1 3/8"	GNS12	BLNS12
1"	1 1/2"	GNS16	BLNS16
1 1/4"	1 5/8"	GNS20	BLNS20
1 1/2"	1 3/4"	GNS24	BLNS24
2"	2"	GNS32	BLNS32
1/8" Pipe			
Close		GNS2	BLNS2
1 1/2"		GNL215	BLNL215
2"		GNL220	BLNL220
2 1/2"		GNL225	BLNL225
3"		GNL230	BLNL230
3 1/2"		GNL235	BLNL235
4"		GNL240	BLNL240
4 1/2"		GNL245	BLNL245
5"		GNL250	BLNL250
5 1/2"		GNL255	BLNL255
6"		GNL260	BLNL260
7"		GNL270	BLNL270
8"		GNL280	BLNL280
9"		GNL290	BLNL290
10"		GNL2100	BLNL2100
12"		GNL2120	BLNL2120
1/4" Pipe			
Close		GNS4	BLNS4
1 1/2"		GNL415	BLNL415
2"		GNL420	BLNL420
2 1/2"		GNL425	BLNL425
3"		GNL430	BLNL430
3 1/2"		GNL435	BLNL435
4"		GNL440	BLNL440
4 1/2"		GNL445	BLNL445
5"		GNL450	BLNL450
5 1/2"		GNL455	BLNL455
6"		GNL460	BLNL460
7"		GNL470	BLNL470
8"		GNL480	BLNL480
9"		GNL490	BLNL490
10"		GNL4100	BLNL4100
11"		GNL4110	BLNL4110
12"		GNL4120	BLNL4120
3/8" Pipe			
Close		GNS6	BLNS6
1 1/2"		GNL615	BLNL615
2"		GNL620	BLNL620
2 1/2"		GNL625	BLNL625
3"		GNL630	BLNL630
3 1/2"		GNL635	BLNL635
4"		GNL640	BLNL640
4 1/2"		GNL645	BLNL645
5"		GNL650	BLNL650
5 1/2"		GNL655	BLNL655
6"		GNL660	BLNL660
8"		GNL680	BLNL680



1/2" Pipe		
Length	Galvanized Part Number	Black Pipe Part Number
Close	GNS8	BLNS8
1 1/2"	GNL815	BLNL815
2"	GNL820	BLNL820
2 1/2"	GNL825	BLNL825
3"	GNL830	BLNL830
3 1/2"	GNL835	BLNL835
4"	GNL840	BLNL840
4 1/2"	GNL845	BLNL845
5"	GNL850	BLNL850
5 1/2"	GNL855	BLNL855
6"	GNL860	BLNL860
7"	GNL870	
12"	GNL8120	
3/4" Pipe		
Close	GNS12	BLNS12
1 1/2"	GNL1215	BLNL1215
2"	GNL1220	BLNL1220
2 1/2"	GNL1225	BLNL1225
3"	GNL1230	BLNL1230
3 1/2"	GNL1235	BLNL1235
4"	GNL1240	BLNL1240
4 1/2"	GNL1245	BLNL1245
5"	GNL1250	BLNL1250
5 1/2"	GNL1255	BLNL1255
6"	GNL1260	BLNL1260
8"	GNL1280	
1" Pipe		
Close	GNS16	BLNS16
2"	GNL1620	BLNL1620
2 1/2"	GNL1625	BLNL1625
3"	GNL1630	BLNL1630
3 1/2"	GNL1635	BLNL1635
4"	GNL1640	BLNL1640
4 1/2"	GNL1645	BLNL1645
5"	GNL1650	BLNL1650
5 1/2"	GNL1655	BLNL1655
6"	GNL1660	BLNL1660
1 1/4" Pipe		
Close	GNS20	BLNS20
2"	GNL2020	BLNL2020
2 1/2"	GNL2025	BLNL2025
3"	GNL2030	BLNL2030
3 1/2"	GNL2035	BLNL2035
4"	GNL2040	BLNL2040
4 1/2"	GNL2045	BLNL2045
5"	GNL2050	BLNL2050
5 1/2"	GNL2055	BLNL2055
6"	GNL2060	BLNL2060
1 1/2" Pipe		
Close	GNS24	BLNS24
2"	GNL2420	BLNL2420
2 1/2"	GNL2425	BLNL2425
3"	GNL2430	BLNL2430
3 1/2"	GNL2435	BLNL2435
4"	GNL2440	BLNL2440
4 1/2"	GNL2445	BLNL2445
5"	GNL2450	BLNL2450
5 1/2"	GNL2455	BLNL2455



# Galvanized & Black Pipe Fittings



## GALVANIZED & BLACK PIPE FITTINGS



### Tees

Size	Galvanized Part Number	Black Part Number
1/8"	GPT2	BLPT2
1/4"	GPT4	BLPT4
3/8"	GPT6	BLPT6
1/2"	GPT8	BLPT8
3/4"	GPT12	BLPT12
1"	GPT16	BLPT16
1 1/4"	GPT20	BLPT20
1 1/2"	GPT24	BLPT24
2"	GPT32	BLPT32



### Square Head Plugs

Size	Galvanized Part Number	Black Part Number
1/8"	GSP2	BLSP2
1/4"	GSP4	BLSP4
3/8"	GSP6	BLSP6
1/2"	GSP8	BLSP8
3/4"	GSP12	BLSP12
1"	GSP16	BLSP16
1 1/4"	GSP20	BLSP20



### Reduced Couplings

Size	Galvanized Part Number	Black Part Number
1/4 x 1/8"	GRC4-2	BLRC4-2
3/8 x 1/8"	GRC6-2	BLRC6-2
3/8 x 1/4"	GRC6-4	BLRC6-4
1/2 x 1/8"	GRC8-2	BLRC8-2
1/2 x 1/4"	GRC8-4	BLRC8-4
1/2 x 3/8"	GRC8-6	BLRC8-6
3/4 x 1/4"	GRC12-4	BLRC12-4
3/4 x 3/8"	GRC12-6	BLRC12-6
3/4 x 1/2"	GRC12-8	BLRC12-8
1 x 1/2"	GRC16-8	BLRC16-8
1 x 3/4"	GRC16-12	BLRC16-12
1 1/4 x 1/2"	GRC20-8	BLRC20-8
1 1/4 x 3/4"	GRC20-12	BLRC20-12
1 1/4 x 1"	GRC20-16	BLRC20-16
1 1/2 x 1/2"	GRC24-8	BLRC24-8
1 1/2 x 3/4"	GRC24-12	BLRC24-12
1 1/2 x 1"	GRC24-16	BLRC24-16
1 1/2 x 1 1/4"	GRC24-20	BLRC24-20
2 x 1"	GRC32-16	BLRC32-16
2 x 1 1/4"	GRC32-20	BLRC32-20
2 x 1 1/2"	GRC32-24	BLRC32-24



### Hex Bushings

Size	Galvanized Part Number	Black Part Number
<b>Machined</b>		
1/4 x 1/8"	GPBM4-2	BLPBM4-2
3/8 x 1/8"	GPBM6-2	BLPBM6-2
3/8 x 1/4"	GPBM6-4	BLPBM6-4
<b>Malleable</b>		
3/8 x 1/4"	GPB6-4	
1/2 x 1/8"	GPB8-2	BLPB8-2
1/2 x 1/4"	GPB8-4	BLPB8-4
1/2 x 3/8"	GPB8-6	BLPB8-6
3/4 x 1/8"	GPB12-2	
3/4 x 1/4"	GPB12-4	BLPB12-4
3/4 x 3/8"	GPB12-6	BLPB12-6
3/4 x 1/2"	GPB12-8	BLPB12-8
1 x 3/8"	GPB16-6	BLPB16-6
1 x 1/2"	GPB16-8	BLPB16-8
1 x 3/4"	GPB16-12	BLPB16-12
1 1/4 x 3/8"	GPB20-6	
1 1/4 x 1/2"	GPB20-8	BLPB20-8
1 1/4 x 3/4"	GPB20-12	BLPB20-12
1 1/4 x 1"	GPB20-16	BLPB20-16
1 1/2 x 1/2"	GPB24-8	BLPB24-8
1 1/2 x 3/4"	GPB24-12	BLPB24-12
1 1/2 x 1"	GPB24-16	BLPB24-16
1 1/2 x 1 1/4"	GPB24-20	BLPB24-20
2 x 1/2"	GPB32-8	BLPB32-8
2 x 3/4"	GPB32-12	BLPB32-12
2 x 1"	GPB32-16	BLPB32-16
2 x 1 1/4"	GPB32-20	BLPB32-20
2 x 1 1/2"	GPB32-24	BLPB32-24

E





# Galvanized & Black Pipe Fittings

## GALVANIZED & BLACK PIPE FITTINGS

### 90° Street Elbows

Size	Galvanized Part Number	Black Part Number
1/8"	GE9S2-2	BLE9S2-2
1/4"	GE9S4-4	BLE9S4-4
3/8"	GE9S6-6	BLE9S6-6
1/2"	GE9S8-8	BLE9S8-8
3/4"	GE9S12-12	BLE9S12-12
1"	GE9S16-16	BLE9S16-16
1 1/4"	GE9S20-20	BLE9S20-20
1 1/2"	GE9S24-24	BLE9S24-24
2"	GE9S32-32	BLE9S32-32



### 45° Street Elbows

Size	Galvanized Part Number	Black Part Number
1/8"	GE4S2-2	BLE4S2-2
1/4"	GE4S4-4	BLE4S4-4
3/8"	GE4S6-6	BLE4S6-6
1/2"	GE4S8-8	BLE4S8-8
3/4"	GE4S12-12	BLE4S12-12
1"	GE4S16-16	BLE4S16-16
1 1/4"	GE4S20-20	BLE4S20-20
1 1/2"	GE4S24-24	BLE4S24-24
2"	GE4S32-32	BLE4S32-32



### 90° Elbows

Size	Galvanized Part Number	Black Part Number
1/8"	GE9-2-2	BLE9-2-2
1/4"	GE9-4-4	BLE9-4-4
3/8 x 1/4"	GE9-6-4	BLE9-6-4
3/8"	GE9-6-6	BLE9-6-6
1/2 x 3/8"	GE9-8-6	BLE9-8-6
1/2"	GE9-8-8	BLE9-8-8
3/4 x 1/2"	GE9-12-8	BLE9-12-8
3/4"	GE9-12-12	BLE9-12-12
1 x 3/4"	GE9-16-12	BLE9-16-12
1"	GE9-16-16	BLE9-16-16
1 1/4 x 1"	GE9-20-16	BLE9-20-16
1 1/4"	GE9-20-20	BLE9-20-20
1 1/2 x 1 1/4"	GE9-24-20	BLE9-24-20
1 1/2"	GE9-24-24	BLE9-24-24
2 x 1 1/2"	GE9-32-24	BLE9-32-24
2"	GE9-32-32	BLE9-32-32



### 45° Elbows

Size	Galvanized Part Number	Black Part Number
1/8"	GE4-2-2	BLE4-2-2
1/4"	GE4-4-4	BLE4-4-4
3/8"	GE4-6-6	BLE4-6-6
1/2"	GE4-8-8	BLE4-8-8
3/4"	GE4-12-12	BLE4-12-12
1"	GE4-16-16	BLE4-16-16
1 1/4"	GE4-20-20	BLE4-20-20
1 1/2"	GE4-24-24	BLE4-24-24
2"	GE4-32-32	BLE4-32-32

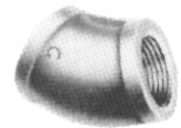

### Pipe Caps

Size	Galvanized Part Number	Black Part Number
1/8"	GPCA2	BLCA2
1/4"	GPCA4	BLCA4
3/8"	GPCA6	BLCA6
1/2"	GPCA8	BLCA8
3/4"	GPCA12	BLCA12
1"	GPCA16	BLCA16
1 1/4"	GPCA20	BLCA20
1 1/2"	GPCA24	BLCA24
2"	GPCA32	BLCA32

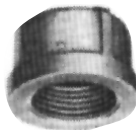

### Pipe Cross

Size	Galvanized Part Number	Black Part Number
1/8"	GCR2	BLCR2
1/4"	GCR4	BLCR4
3/8"	GCR6	BLCR6
1/2"	GCR8	BLCR8
3/4"	GCR12	BLCR12
1"	GCR16	BLCR16
1 1/4"	GCR20	BLCR20
1 1/2"	GCR24	BLCR24
2"	GCR32	BLCR32



# Galvanized & Black Pipe Fittings



## GALVANIZED & BLACK PIPE FITTINGS

### Pipe Unions - 150 lb.

Size	Galvanized Part Number	Black Part Number
1/8"	GPU2	BLPU2
1/4"	GPU4	BLPU4
3/8"	GPU6	BLPU6
1/2"	GPU8	BLPU8
3/4"	GPU12	BLPU12
1"	GPU16	BLPU16
1 1/4"	GPU20	BLPU20
1 1/2"	GPU24	BLPU24
2"	GPU32	BLPU32

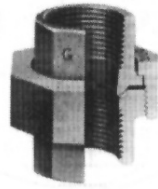

### Pipe Coupling

Size	Galvanized Part Number	Black Part Number
1/8"	GPC2-2	BLPC2-2
1/4"	GPC4-4	BLPC4-4
3/8"	GPC6-6	BLPC6-6
1/2"	GPC8-8	BLPC8-8
3/4"	GPC12-12	BLPC12-12
1"	GPC16-16	BLPC16-16
1 1/4"	GPC20-20	BLPC20-20
1 1/2"	GPC24-24	BLPC24-24
2"	GPC32-32	BLPC32-32



## Push-in Tube Fittings

### Features

- Easy one-piece connection
- No tools or extra components needed to connect fitting
- Fittings designed to work with polyurethane, nylon and polyethylene tubing
- Reduced assembly time...up to 75% savings compared to compression fittings
- Automatically locks and seals to max. working pressure
- Wide-release collar allows fast and easy removal of tubing for line checks
- Positive gripping-action of locking teeth allows tubing to withstand vibration with or without pressure
- Because there is no nut, fittings can be closely mounted
- Unrestricted tube I.D. allows for maximum airflow
- Poly-matic fittings are fully reusable
- Silicon-free O-rings

### Specifications

- Working pressure: From 27" Hg to 250 PSI
- Working temperature: -40°F to +200°F
- Materials: Brass body, spring brass locking teeth, oil-resistant Buna-N O-ring, tough Delrin release collar
- Fluid applications: Compressed air, oil, water or other non-corrosive liquids
- To connect tubing - simply push the tubing into the fitting until it bottoms; to remove tubing - push in release collar; while pressing on collar, pull tubing out.

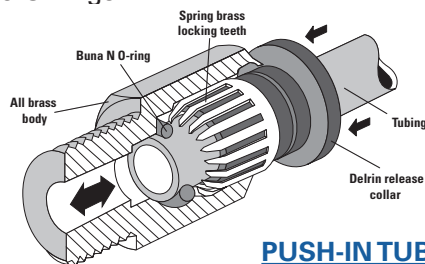

### PUSH-IN TUBE FITTINGS

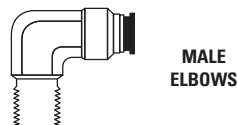

MALE ELBOWS

### Male Elbows

Tube OD	Pipe Thread	Part Number
5/32	10-32 UNF	55010
5/32	1/8	56912
5/32	1/4	56914
1/4	1/8	56942
1/4	1/4	56944
3/8	1/4	56964
3/8	3/8	56966
1/2	3/8	56986
1/2	1/2	56988



# Push-In Tube Fittings

## PUSH-IN TUBE FITTINGS

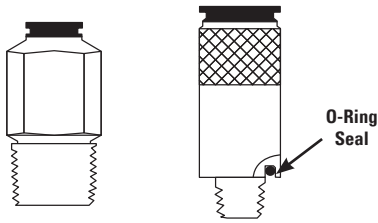

MALE CONNECTORS

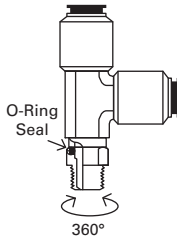

MALE SWIVEL RUN TEE

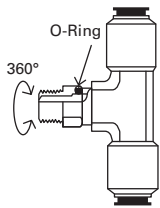

MALE SWIVEL BRANCH TEE

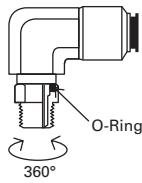

360° SWIVEL ELBOWS



UNION REDUCER



STRAIGHT UNION

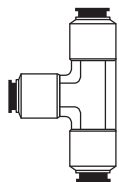

UNION TEE

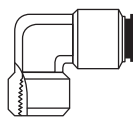

FEMALE ELBOW

Tube O.D.	Pipe Thread	Part Number
<b>Male Connectors</b>		
5/32	10/32 UNF	56810
5/32	1/8	56812
5/32	1/4	56814
1/4	10/32 UNF	56840
1/4	1/8	56842
1/4	1/4	56844
1/4	3/8	56846
3/8	1/4	56864
3/8	3/8	56866
3/8	1/2	56868
1/2	3/8	56886
1/2	1/2	56888
<b>Male Swivel Run Tee</b>		
1/4	1/8	57142
1/4	1/4	57144
3/8	3/8	57164
1/2	1/2	57188
<b>Male Swivel Branch Tee</b>		
1/4	1/8	57242
1/4	1/4	57244
<b>360° Swivel Elbows</b>		
5/32	1/8	57912
5/32	1/4	57914
1/4	1/8	57942
1/4	1/4	57944
1/4	3/8	57946
3/8	1/4	57964
3/8	3/8	57966
1/2	3/8	57986
1/2	1/2	57988
<b>Union Reducer</b>		
1/4	1/8	59742
1/4	5/32	59741
3/8	1/4	59764
1/2	3/8	59786
<b>Straight Union</b>		
5/32	—	56211
1/4	—	56244
3/8	—	56266
1/2	—	56288
<b>Union Tee</b>		
1/4	—	56444
3/8	—	56466
<b>Female Elbow</b>		
1/4	1/8	57042
1/4	1/4	57044
3/8	1/4	57064

# Push-In Tube Fittings

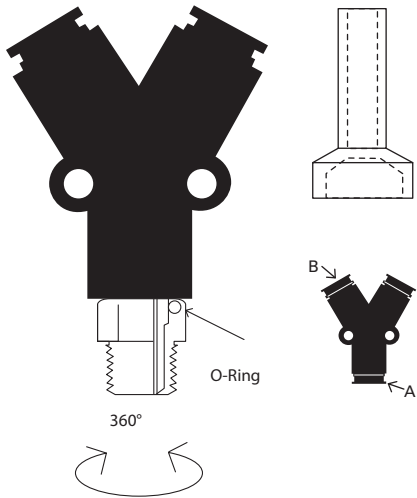

Tube O.D.	Pipe Thread	Part Number
<b>Branch "Y"</b>		
5/32	1/8	54312
3/8	3/8	54366
<b>Plug</b>		
1/8	—	52620
5/32	—	52610
1/4	—	52640
3/8	—	52660
1/2	—	52680
<b>Union "Y"</b>		
5/32 (3 PT)	5/32	54011
1/4 (3 PT)	5/32	54114
1/4 (3 PT)	1/4	54144

## Cam & Groove Couplings

- Very low cost
- Interchangeable with other brands
- For use with pneumatic conveying and low pressure liquids  
-20° to 200°F
- Special seals may be required for oils and aromatics; please consult DME when ordering



Type A



Type B

Size	Aluminum	Brass	Stainless
3/4"	A75AL	A75BR	A75SS
1"	A1AL	A1BR	A1SS
1 1/4"	A125AL	A125BR	A125SS
1 1/2"	A150AL	A150BR	A150SS
2"	A2AL	A2BR	A2SS
2 1/2"	A250AL	A250BR	A250SS
3"	A3AL	A3BR	A3SS
4"	A4AL	A4BR	A4SS
5"	A5AL	A5BR	
6"	A6AL	A6BR	
3/4"	B75AL	B75BR	B75SS
1"	B1AL	B1BR	B1SS
1 1/4"	B125AL	B125BR	B125SS
1 1/2"	B150AL	B150BR	B150SS
2"	B2AL	B2BR	B2SS
2 1/2"	B250AL	B250BR	B250SS
3"	B3AL	B3BR	B3SS
4"	B4AL	B4BR	B4SS
5"	B5AL	B5BR	
6"	B6AL	B6BR	

### CAM & GROOVE COUPLINGS



# Cam & Groove Couplings

## CAM & GROOVE COUPLINGS



Type C

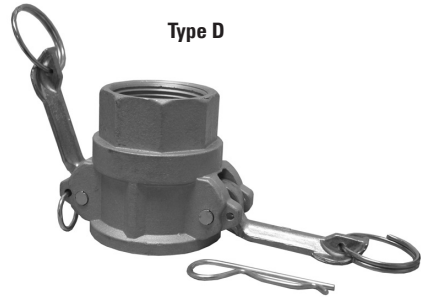

Type D



Type E



Type F



Type DC

Size	Aluminum	Brass	Stainless
3/4"	C75AL	C75BR	C75SS
1"	C1AL	C1BR	C1SS
1 1/4"	C125AL	C125BR	C125SS
1 1/2"	C150AL	C150BR	C150SS
2"	C2AL	C2BR	C2SS
2 1/2"	C250AL	C250BR	C250SS
3"	C3AL	C3BR	C3SS
4"	C4AL	C4BR	C4SS
5"	C5AL	C5BR	
6"	C6AL	C6BR	
3/4"	D75AL	D75BR	D75SS
1"	D1AL	D1BR	D1SS
1 1/4"	D125AL	D125BR	D125SS
1 1/2"	D150AL	D150BR	D150SS
2"	D2AL	D2BR	D2SS
2 1/2"	D250AL	D250BR	D250SS
3"	D3AL	D3BR	D3SS
4"	D4AL	D4BR	D4SS
5"	D5AL	D5BR	
6"	D6AL	D6BR	
3/4"	E75AL	E75BR	E75SS
1"	E1AL	E1BR	E1SS
1 1/4"	E125AL	E125BR	E125SS
1 1/2"	E150AL	E150BR	E150SS
2"	E2AL	E2BR	E2SS
2 1/2"	E250AL	E250BR	E250SS
3"	E3AL	E3BR	E3SS
4"	E4AL	E4BR	E4SS
5"	E5AL	E5BR	
6"	E6AL	E6BR	
3/4"	F75AL	F75BR	F75SS
1"	F1AL	F1BR	F1SS
1 1/4"	F125AL	F125BR	F125SS
1 1/2"	F150AL	F150BR	F150SS
2"	F2AL	F2BR	F2SS
2 1/2"	F250AL	F250BR	F250SS
3"	F3AL	F3BR	F3SS
4"	F4AL	F4BR	F4SS
5"	F5AL	F5BR	
6"	F6AL	F6BR	
3/4"	DC75AL	DC75BR	DC75SS
1"	DC1AL	DC1BR	DC1SS
1 1/4"	DC125AL	DC125BR	DC125SS
1 1/2"	DC150AL	DC150BR	DC150SS
2"	DC2AL	DC2BR	DC2SS
2 1/2"	DC250AL	DC250BR	DC250SS
3"	DC3AL	DC3BR	DC3SS
4"	DC4AL	DC4BR	DC4SS
5"	DC5AL	DC5BR	
6"	DC6AL	DC6BR	

# Cam & Groove Couplings



Type DP



Size	Aluminum	Brass	Stainless
3/4"	DP75AL	DP75BR	DP75SS
1"	DP1AL	DP1BR	DP1SS
1 1/4"	DP125AL	DP125BR	DP125SS
1 1/2"	DP150AL	DP150BR	DP150SS
2"	DP2AL	DP2BR	DP2SS
2 1/2"	DP250AL	DP250BR	DP250SS
3"	DP3AL	DP3BR	DP3SS
4"	DP4AL	DP4BR	DP4SS
5"	DP5AL	DP5BR	
6"	DP6AL	DP6BR	

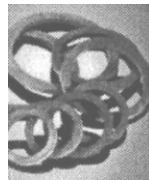

## Gaskets

Size	Part Number	Size	Part Number
3/4"	CGG034	2-1/2"	CGG212
1"	CGG100	3"	CGG300
1-1/4"	CGG114	4"	CGG400
1-1/2"	CGG112	5"	CGG500
2"	CGG200	6"	CGG600

# Bronze "Y" Pattern Strainer

E

Y-strainers are constructed of heavy-duty bronze. They have a 20 mesh 304 stainless steel screen in sizes "-2" and a 1/16" perforated strainer in 2" and 3". The bronze retainer cap is gasketed and tapped for a closure plug (closure plug furnished). Install strainers upstream to protect valves, regulators, and meters, etc. from rust, pipe scale and dirt. Self cleaning can be accomplished by opening the valve or plug connected to the blow-off outlet.

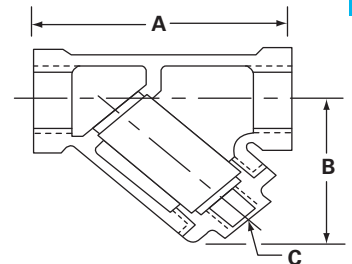

- Y pattern body
- 304 stainless steel screen
- 300 PSI WOG non-shock
- Screwed cap and plug
- Threaded ends
- 150 PSI saturated steam

Part	Specifications
Body	Bronze
Cap	Bronze
Screen	Type 304 S.S.

Part Number	Thread Size	A	B	C (NPT)	Replacement Strainers
					Part Number
BYS523	1/2"	2.94	2.95	1/4"	BYS523R
BYS524	3/4"	3.38	3.37	1/4"	BYS524R
BYS525	1"	4.13	3.97	3/8"	BYS525R
BYS526	1-1/4"	4.82	4.55	3/8"	BYS526R
BYS527	1-1/2"	5.38	4.94	1/2"	BYS527R
BYS528	2"	6.63	6.25	1/2"	BYS528R
BYS529	2-1/2"	9.00	7.5	1-1/4"	BYS529R
BYS530	3"	10.00	8.5	1-1/2"	BYS530R

## BRONZE Y PATTERN STRAINER





# Split Flange Adapters

- One-piece carbon steel construction simplifies installation, eliminates potential leak points
- Zinc dichromate finish for high corrosion resistance
- Compact design simplifies assembly
- Optional thread configurations - BSPP and NPTF (call DME for availability)

JIC Thread					
Part Number	Tube O.D.	Flange Size	A	B	Thread
<b>Code 61</b>					
300-8-8	1/2	1/2	2.60	1.188	3/4-16
300-8-12	1/2	3/4	2.75	1.500	3/4-16
300-12-12	3/4	3/4	2.75	1.500	1 1/16-12
300-16-12	1	3/4	2.75	1.500	1 5/16-12
300-12-16	3/4	1	2.80	1.750	1 1/16-12
300-16-16	1	1	2.80	1.750	1 5/16-12
300-20-16	1 1/4	1	2.80	1.750	1 5/8-12
300-16-20	1	1 1/4	2.80	2.000	1 5/16-12
300-20-20	1 1/4	1 1/4	2.80	2.000	1 5/8-12
300-24-20	1 1/2	1 1/4	3.40	2.000	1 7/8-12
300-20-24	1 1/4	1 1/2	3.50	2.375	1 5/8-12
300-24-24	1 1/2	1 1/2	3.50	2.375	1 7/8-12
300-32-24	2	1 1/2	4.20	2.375	2 1/2-12
300-24-32	1 1/2	2	3.73	2.812	1 7/8-12
300-32-32	2	2	3.98	2.812	2 1/2-12
<b>Code 62</b>					
600-12-12	3/4	3/4	2.75	1.625	1 1/16-12
600-16-12	1	3/4	2.75	1.625	1 5/16-12
600-12-16	3/4	1	2.80	1.875	1 1/16-12
600-16-16	1	1	2.80	1.875	1 5/16-12
600-20-16	1 1/4	1	2.80	1.875	1 5/8-12
600-16-20	1	1 1/4	3.05	2.125	1 5/16-12
600-20-20	1 1/4	1 1/4	3.05	2.125	1 5/8-12
600-24-20	1 1/2	1 1/4	3.30	2.125	1 7/8-12
600-20-24	1 1/4	1 1/2	3.50	2.500	1 5/8-12
600-24-24	1 1/2	1 1/2	3.50	2.500	1 7/8-12
600-32-24	2	1 1/2	4.94	2.500	2 1/2-12
600-24-32	1 1/2	2	3.98	3.125	1 7/8-12
600-32-32	2	2	4.23	3.125	2 1/2-12

## SPLIT FLANGE ADAPTERS-JIS

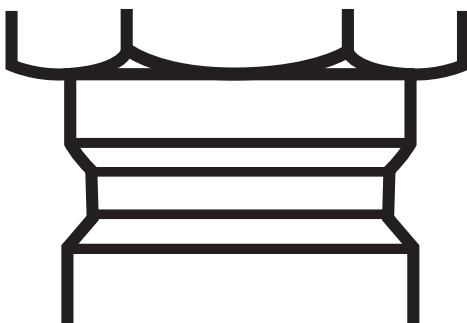

### Ordering System:

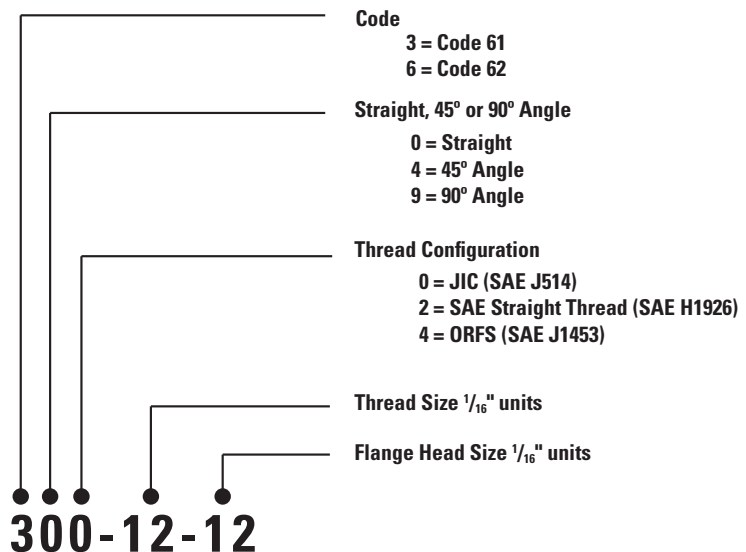

# Split Flange Adapters



## ORFS Thread

Part Number	Tube O.D.	Flange Size	A	B	Thread
<b>Code 61</b>					
304-12-12	3/4	3/4	2.75	1.500	1 3/16-12
304-16-12	1	3/4	2.75	1.500	1 7/16-12
304-12-16	3/4	1	2.80	1.750	1 3/16-12
304-16-16	1	1	2.80	1.750	1 7/16-12
304-20-16	1 1/4	1	2.80	1.750	1 11/16-12
304-16-20	1	1 1/4	2.80	2.000	1 7/16-12
304-20-20	1 1/4	1 1/4	2.80	2.000	1 11/16-12
304-24-20	1 1/2	1 1/4	3.20	2.000	2-12
304-20-24	1 1/4	1 1/2	3.50	2.375	1 11/16-12
304-24-24	1 1/2	1 1/2	3.50	2.375	2-12
304-24-32	1 1/2	2	3.33	2.812	2-12
<b>Code 62</b>					
604-8-8	1/2	1/2	2.58	1.250	1 3/16-16
604-12-12	3/4	3/4	2.75	1.625	1 3/16-12
604-16-12	1	3/4	2.75	1.625	1 7/16-12
604-12-16	3/4	1	2.80	1.875	1 3/16-12
604-16-16	1	1	2.80	1.875	1 7/16-12
604-20-16	1 1/4	1	3.20	1.875	1 11/16-12
604-16-20	1	1 1/4	3.05	2.125	1 7/16-12
604-20-20	1 1/4	1 1/4	3.05	2.125	1 11/16-12
604-24-20	1 1/2	1 1/4	3.30	2.125	2-12
604-20-24	1 1/4	1 1/2	3.50	2.500	1 11/16-12
604-24-24	1 1/2	1 1/2	3.50	2.500	2-12
604-24-32	1 1/2	2	3.581	3.125	2-12

## SPLIT FLANGE ADAPTERS-ORFS

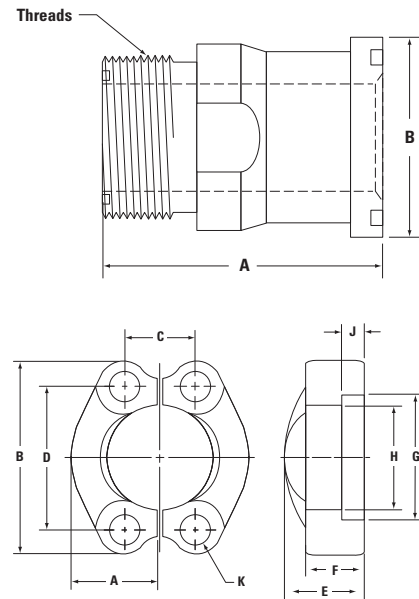

## CONTACT US

### Split Flange Kits

Flange Half No.	*KIT	Flange Size	A	B	D	E	F	G	H	J	K	O-Ring	HHCS
<b>Code 61</b>													
8SF-2	8SFO	0.50	0.86	2.12	1.50	0.75	0.5	1.22	0.96	0.245	0.344	210	5/16-18 x 1.25
12SF-2	12SFO	0.75	0.98	2.56	1.88	0.88	0.56	1.53	1.27	0.245	0.406	214	3/8-16 x 1.25
16SF-2	16SFO	1.00	1.11	2.75	2.06	0.94	0.62	1.78	1.52	0.295	0.406	219	3/8-16 x 1.25
20SF-2	20SFO	1.25	1.39	3.12	2.31	0.88	0.56	2.03	1.72	0.295	0.469	222	7/16-14 x 1.50
24SF-2	24SFO	1.50	1.58	3.69	2.75	1.00	0.62	2.41	2.00	0.295	0.531	225	1/2-13 x 1.50
32SF-2	32SFO	2.00	1.86	4.00	3.06	1.03	0.62	2.84	2.47	0.355	0.531	228	1/2-13 x 1.50
40SF-2	40SFO	2.50	2.09	4.50	3.50	1.50	0.75	3.34	2.95	0.355	0.531	232	1/2-13 x 1.75
48SF-2	48SFO	3.00	2.53	5.31	4.19	1.62	0.88	4.03	3.58	0.355	0.656	237	5/8-11 x 1.75
56SF-2	56SFO	3.50	2.70	6.00	4.75	1.12	0.88	4.53	4.03	0.422	0.656	241	5/8-11 x 2.00
64SF-2	64SFO	4.00	2.95	6.38	5.13	1.38	1.00	5.03	4.53	0.422	0.656	245	5/8-11 x 2.00
<b>Code 62</b>													
8SFX-2	8SFXO	0.50	0.89	2.22	1.59	0.88	0.62	1.28	.970	0.285	0.344	210	5/16-18 x 1.25
12SFX-2	12SFXO	0.75	1.14	2.81	2.00	1.12	0.75	1.66	1.28	0.325	0.406	214	3/8-16 x 1.50
16SFX-2	16SFXO	1.00	1.33	3.19	2.25	1.31	0.94	1.91	1.53	0.355	0.469	219	7/16-14 x 1.75
20SFX-2	20SFXO	1.25	1.48	3.75	2.63	1.50	1.06	2.16	1.75	0.385	0.531	222	1/2-13 x 1.75
24SFX-2	24SFXO	1.50	1.83	4.44	3.13	1.69	1.19	2.53	2.03	0.475	0.656	225	5/8-11 x 2.25
32SFX-2	32SFXO	2.00	2.20	5.25	3.81	2.06	1.44	3.16	2.66	0.475	0.781	228	3/4-10 x 2.75

\* Kit includes (2) split flange halves, (4) hex head bolts & lock washers and (1) Buna N o-ring.



# Split Flange Adapters

## 45° JIC Thread

Part Number	Tube O.D.	Flange Size	A	B	C	Thread
<b>CODE 61</b>						
340-12-12	3/4	3/4	1.500	1.28	1.58	1 1/16-12
340-16-16	1	1	1.750	1.47	1.85	1 5/16-12
340-20-20	1 1/4	1 1/4	2.000	1.59	2.04	1 5/8-12
340-24-24	1 1/2	1 1/2	2.375	1.78	2.38	1 7/8-12
340-32-32	2	2	2.812	2.22	3.00	2 1/2-12
<b>CODE 62</b>						
640-12-12	3/4	3/4	1.625	1.28	1.58	1 1/16-12
640-16-16	1	1	1.875	1.47	1.85	1 5/16-12
640-20-20	1 1/4	1 1/4	2.125	1.59	2.04	1 5/8-12
640-24-24	1 1/2	1 1/2	2.500	1.78	2.38	1 7/8-12
640-32-32	2	2	3.125	2.22	3.00	2 1/2-12

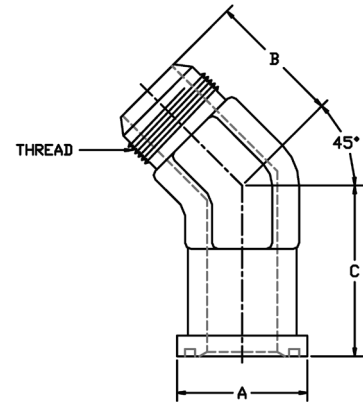

**SPLIT FLANGE ADAPTERS-JIS**

## 45° ORFS Thread

Part Number	Tube O.D.	Flange Size	A	B	C	Thread
<b>CODE 61</b>						
344-12-12	3/4	3/4	1.500	1.28	1.58	1 3/16-12
344-16-16	1	1	1.750	1.47	1.85	1 7/16-12
344-20-20	1 1/4	1 1/4	2.000	1.59	2.04	1 11/16-12
344-24-24	1 1/2	1 1/2	2.375	1.78	2.38	2-12
<b>CODE 62</b>						
644-12-12	3/4	3/4	1.625	1.28	1.58	1 3/16-12
644-16-16	1	1	1.875	1.47	1.85	1 7/16-12
644-20-20	1 1/4	1 1/4	2.125	1.59	2.04	1 11/16-12
644-24-24	1 1/2	1 1/2	2.500	1.78	2.38	2-12

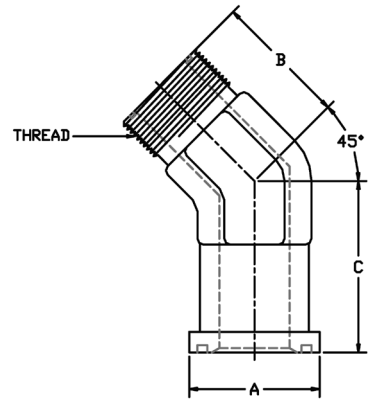

**SPLIT FLANGE ADAPTERS-ORFS**

# Split Flange Adapters

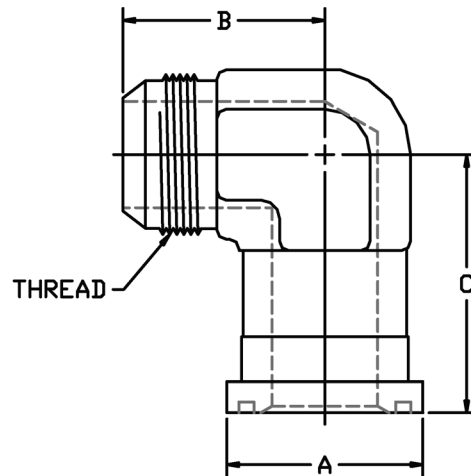

## 90° JIC Thread

Part Number	Tube O.D.	Flange Size	A	B	C	Thread
<b>CODE 61</b>						
390-8-12	1/2	3/4	1.500	1.660	2.130	3/4-16
390-12-12	3/4	3/4	1.500	1.660	2.130	1 1/16-12
390-16-12	1	3/4	1.500	1.660	2.130	1 5/16-12
390-12-16	3/4	1	1.750	1.810	2.370	1 1/16-12
390-16-16	1	1	1.750	1.810	2.370	1 5/16-12
390-20-16	1 1/4	1	1.750	1.810	2.370	1 5/8-12
390-16-20	1	1 1/4	2.000	2.060	2.620	1 5/16-12
390-20-20	1 1/4	1 1/4	2.000	2.060	2.620	1 5/8-12
390-20-24	1 1/4	1 1/2	2.375	2.330	3.150	1 5/8-12
390-24-24	1 1/2	1 1/2	2.375	2.330	3.150	1 7/8-12
390-32-24	2	1 1/2	2.375	2.330	3.150	2 1/2-12
390-24-32	1 1/2	2	2.812	3.060	4.250	1 7/8-12
390-32-32	2	2	2.812	3.060	4.250	2 1/2-12
<b>CODE 62</b>						
690-12-12	3/4	3/4	1.625	1.660	2.130	1 1/16-12
690-16-12	1	3/4	1.625	1.660	2.130	1 5/16-12
690-12-16	3/4	1	1.875	1.810	2.370	1 1/16-12
690-16-16	1	1	1.875	1.810	2.370	1 5/16-12
690-20-16	1 1/4	1	1.875	1.810	2.370	1 5/8-12
690-16-20	1	1 1/4	2.125	2.060	2.760	1 5/16-12
690-20-20	1 1/4	1 1/4	2.125	2.060	2.760	1 5/8-12
690-24-20	1 1/2	1 1/4	2.125	2.190	2.760	1 7/8-12
690-20-24	1 1/4	1 1/2	2.500	2.330	3.150	1 5/8-12
690-24-24	1 1/2	1 1/2	2.500	2.330	3.150	1 7/8-12
690-32-24	2	1 1/2	2.500	3.060	4.250	2 1/2-12
690-24-32	1 1/2	2	3.125	3.060	4.250	1 7/8-12
690-32-32	2	2	3.125	3.060	4.250	2 1/2-12



# Parker® Hose

## Jiffy™ Push-On Multipurpose Oil Resistant Hose Series 7212

Parker's Series 7212 Jiffy Push-On/Push Lock Oil Resistant Multipurpose Industrial Hose provides excellent service across a wide variety of media and multiple applications. This hose is designed to transfer air, mild chemicals, oil, water, and refined fuels such as biodiesel, ethanol, and gasoline in applications 212° F and 300 PSI. The flexible hose construction is compatible with push-on couplings for easy and secure attachment in the field and at the jobsite.

The flame retardant cover protects operators from fire hazards and is available in multiple colors for easy identification. Series 7212 is an abrasion, oil and weather resistant hose that provides versatile service in many common industrial applications.



**SERIES 7212 HOSE**

2 stock colors available: Red and Blue

Part Number	Hose I. D.	Hose O. D.	Max. W. P.	Feet Per Reel
7212-381BL	3/8"	5/8"	300 (PSI)	700
7212-381RD	3/8"	5/8"		700
7212-501BL	1/2"	3/4"		600
7212-501RD	1/2"	3/4"		600

### Features & Benefits

- **Tube:** Black Class A nitril for exceptional fuel and oil resistance to 212° F and 300 PSI
- **Tube:** Silicone free to eliminate contamination of air powered paint sprays systems
- **Reinforcement:** One textile braid for strength and kink resistance
- **Cover:** Chloroprene for abrasion, flame oil and weather resistance
- **Cover Colors:** Blue and Red for easy identification (additional colors can be quoted through our specials group)
- **Couplings:** Push-on; also qualified with steel crimp couplings for a durable, safe, and secure connection

**WARNINGS:** The hose does not include a static wire; transfer of refined fuel may create an accumulation and catastrophic discharge of static electrical buildup.

This product can expose you to chemicals including 1,3-Butadiene, which is known to the State of California to cause cancer and birth defects or other reproductive harm. For more information go to [www.p65warnings.ca.gov](http://www.p65warnings.ca.gov).

## Parker® Push-Lok® 801 Color Coded

Standard Duty - Rugged, Reliable...PARKER

For long-term savings and reliable performance Push-Lok Hose from Parker is the first choice! Unmatched in quality and performance.

6 stock colors available:

Red, Blue, Gray, Yellow, Green and Black

Applications: Used worldwide for plastic molding temperature control, shop air and all types of general maintenance.

Temperature Range: -40 to 212°F, except air, 150°F and water, 180°F

Design: Smooth pressed cure synthetic rubber cover, one textile braid reinforcement, synthetic rubber inner tube.

Use for: anti-freeze, water, air, gasoline, diesel & lubrication oils.



Part Number	Hose I. D.	Hose O. D.	Max. W. P.	Min. Burst	Feet Per Reel
801-4-*	1/4"	.50	350 (PSI)	1400 (PSI)	600
801-6-*	3/8"	.63			450
801-8-*	1/2"	.78	300 (PSI)	1200 (PSI)	*300
801-10-*	5/8"	.91			300
801-12-*	3/4"	1.03			200
801-16-*	1"	1.28	200 (PSI)	800 (PSI)	150

\*Specify stock color

**PUSH-LOK HOSE**



High Temperature, Heat Resistant Hose Parker's Push-Lok Pride!  
The right hose to use when elevated temperatures are a problem. The PKR elastomer is compatible with most fluids. If you are having temperature problems with hose this might be just the solution.

Construction: PKR elastomer liner, one fabric braid reinforcement, blue (or black) PKR elastomer cover.  
Temperature Range: -55 to 300°F, except air, 200°F max. and 180°F max. Continuous use at extremes of temp. & pressure will materially reduce service life.  
Applications: anti-freeze, water, air, diesel fuels, lubrication oils, maintenance and general industrial applications.

### Choice of blue or black color.

Part Number	Hose I. D.	Hose O. D.	Max. W. P.	Min. Burst	Feet Per Reel
836-4◆	¼"	.50	400psi	1000psi	600
836-6◆	⅜"	.62	400psi	1000psi	450
836-8◆	½"	.78	400psi	1000psi	300

### HIGH-TEMP. PUSH-LOK HOSE

◆ Add "blue" or "black" to part number to indicated color choice

## Platen Hose Clips

- Metric & inch sizes!
- Low cost, very handy!
- Prevents pinching & abrasion
- Works for tubing too!
- Extends hose life
- Thread sizes to fit most platen holes
- Satisfaction guaranteed!

	Single	Double
Overall Height	2 <sup>9</sup> / <sub>16</sub> "	2 <sup>3</sup> / <sub>8</sub> "
Height Above Base	1 <sup>5</sup> / <sub>8</sub> "	1 <sup>3</sup> / <sub>8</sub> "
Thickness Of Clip	3/8"	3/8"
Clip O. D.	1 <sup>11</sup> / <sub>16</sub> "	2"
Clip I. D.	1 <sup>5</sup> / <sub>32</sub> "	3/4"
Clip Opening	5/8"	3/8"

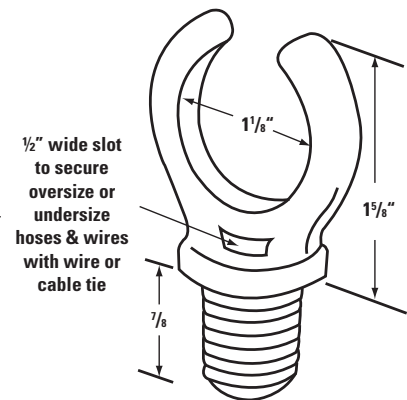
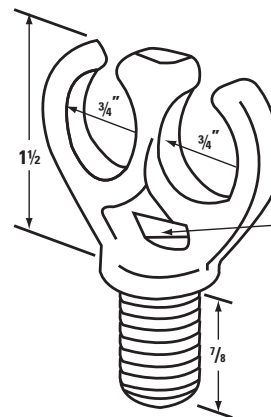

### Single Hose Clip

### Double Hose Clip

### PLATEN HOSE CLIPS

Thread Sizes	Fits Hose Sizes	Part Number	Fits Hose Sizes	Part Number
½-13	FROM	PHC1-8	FROM	PHC2-8
5/8-11	5/8"	PHC1-10	3/8" TO	PHC2-10
¾-10	TO	PHC1-12	¾"	PHC2-12
1-8	1-1/8" O.D.	PHC1-16	O.D.	PHC2-16
M12 x 1.75mm	FROM	PHC1-12M	FROM	PHC2-12M
M14 x 2.00mm	5/8"	PHC1-14M	3/8" TO	PHC2-14M
M16 x 2.00mm	TO	PHC1-16M	¾"	PHC2-16M
M20 x 2.50mm	1-1/8" O.D.	PHC1-20M	O.D.	PHC2-20M





# General Purpose Air & Water Hose

Norflex GP Hose is an economical air and water hose offering limited oil resistance for a variety of uses in industrial applications.

**Strong and Flexible:** GP Hose is reinforced with a single synthetic braid which offers both strength and flexibility. It is ideal for air, water, mild chemicals, alkalies and sprays. It resists the effects of small amounts of oil often found in air lines.

**Pressure Resistance:** GP Hose is made with a strong synthetic cord and will perform well in most applications not exceeding 200 PSI (150 PSI - larger sizes).

Minimum Burst is 800 PSI -20° to 200°F. operating range

## Colors:

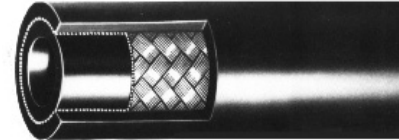

- Black
- Red

Part Number	Ref. No.	Hose I.D.	Hose O.D.	Stock Colors	Working Pressure	Feet Per Reel
GP4*	WLH250	¼"	.47	Red/Black	200PSI	700
GP5RED	WLH312	⅝"	.66	Red	200PSI	700
GP6*	WLH375	⅜"	.66	Red/Black	200PSI	700
GP8*	WLH500	½"	.81	Red/Black	200PSI	700
GP12*	WLH750	¾"	1.08	Red/Black	200PSI	700
GP16*	WLH1000	1"	1.48	Red/Black	200PSI	700
GP20*	-	1¼"	1.73	Red/Black	150PSI	300
GP24*	-	1½"	1.98	Red/Black	150PSI	300

## [GENERAL AIR & WATER](#)

\*Specify color; full 4:1 safety factor.

# Nylon Cable Ties



- Made in USA
- High quality, low price!
- Use for: wire, cable, hose, ducting, retaining and repair

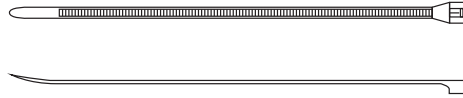

Ties feature a patented locking system that assures a firm grip. These natural-color cable ties have smooth edges and a taper tip for easy installation. UL approved.

## NYLON TIES

### Natural Color (off white) Ties

Part Number	Length O.A.	Max. Dia.	Tensile Looped	Pieces Per Bag
NCT4	4"	$1\frac{3}{16}$ "	18	100
NCT7	7"	$1\frac{3}{4}$ "	50	100
NCT11	11"	3"	50	100
NCT14	14"	4"	50	100
NCT14HD	$14\frac{1}{2}$ "	4"	175	100
NCT24HD	$24\frac{1}{2}$ "	7"	175	50

### Black Color Ties

Part Number	Length O.A.	Max. Dia.	Tensile Looped	Pieces Per Bag
NCT4BLK	4"	$1\frac{3}{16}$ "	18	100
NCT7BLK	7"	$1\frac{3}{4}$ "	50	100
NCT11BLK	11"	3"	50	100
NCT14BLK	14"	4"	50	100
NCT14HDBLK	$14\frac{1}{2}$ "	4"	175	100
NCT24HDBLK	$24\frac{1}{2}$ "	7"	175	50

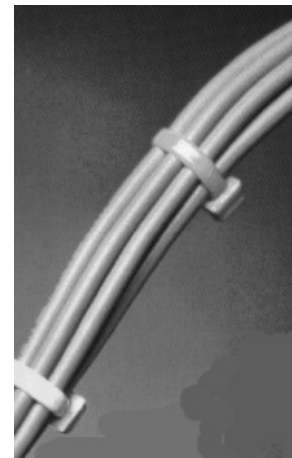

E

## Cable Tie Bases

These Cable Tie Bases make mounting wire and cable a quick, easy and secure process. They are designed so they can be screw-mounted, and they also have an adhesive backing for extra easy application.

### Black Nylon Cable Tie Base

Part Number	Description
6295	0.75" x 0.75" Base
6297	1" x 1" Base

## CABLE BASE

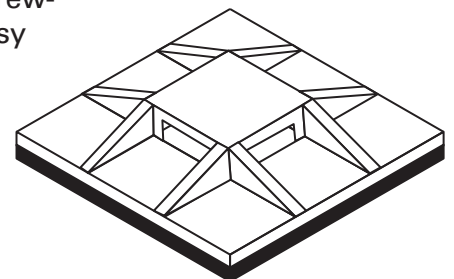



## PTFE Tape

- Permanent non-flammable seal
- Remains plastic permanently
- -450°F to +500°F
- Perfect for water connections, hydraulics, air, gas, petroleum
- This is the finest quality PTFE Tape available
- NEVER use thinner, cheaper substitutes



[PTFE TAPE](#)

Part Number	Length	Thickness	Width
TT100	260" (21.6')	0.0035	1/2"
TT200	520" (43.3')	0.0035	1/2"
TT300	520" (43.3')	0.0035	3/4"

## PVC Silver Duct Tape

- 2" x 180' (60 yards)
- Strong adhesion
- Cloth backed
- High-tensile strength
- Great for use with dryer and loader hose
- Great value

Part Number  
RDT180

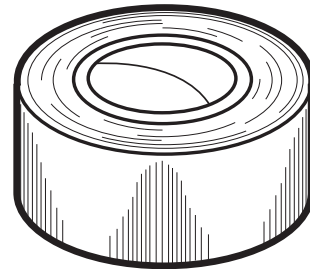

[PVC SILVER DUCT TAPE](#)

## Standard Hose Cutter cuts up to 1½" I.D. hose

- More rigid and sturdy
- Safe, quick & clean
- Replaceable high-carbon, steel blade
- Blade closes into its own handle for safe carrying and handling
- Up to 8 times faster than sawing and deburring
- Cuts PE & PB through 1½" I.D., PVC up to 1¼"
- Ideally suited to limited working space, the cutter adapts easily where a conventional hacksaw cannot be used

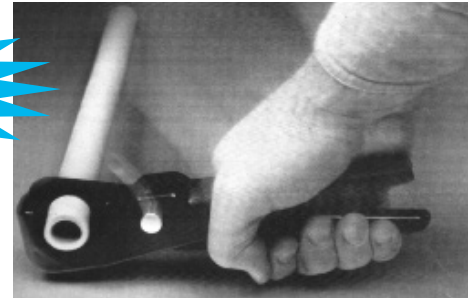

Part Number	Description
T135	Hose Cutter
BT135	Blades for Cutter

## X-Large Hose Cutter cuts up to 2" I.D. hose

- cuts rubber hose and tubing through 2" I.D., P.E., through 1½" I.D., Class PVC through 1¼" I.D.

Part Number	Description
T200	XL Hose Cutter
BT200	Blades for Cutter

### HOSE CUTTERS



## Push-Lok® Cut-off Assembly Tool

**Parker®**

### PUSH-LOK CUT-OFF ASSEMBLY TOOL

This unique tool combines a hose cutter with a toggle-action that presses the fitting into the hose.

Designed to handle Push-Lok hose from ¼" through ¾", this tool makes the job easier whether making one assembly or one hundred.

Overall Length 16"  
Weight approx. 4 pounds

**Part Number 881540**

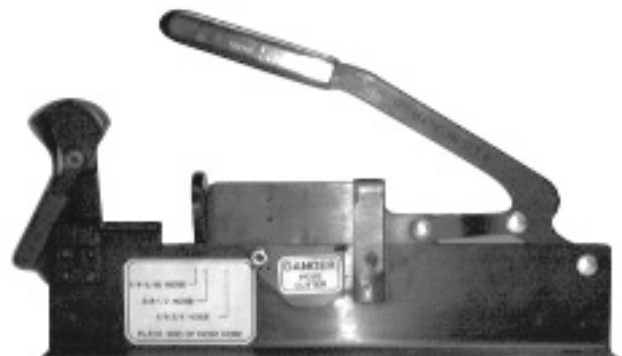



# Hose Reels- B Series

The B Series Reels are best applied where shorter, low-volume hoses are used, such as auto-truck service garages for all air applications as well as anti-freeze, motor oil, ATF and grease. The 100% brass main shaft and swivel assure less corrosion for extended seal life in the low pressure rating (available up to 1000 PSI).

LOW PRESSURE - Air, water, anti-freeze

Hose Reel & 50'

1/4" multi-purpose hose 300 PSI

**Part Number LB250 \*\***

*Inlet is 3/8" NPT  
Max. Temp -200°F*

## HOSE REELS-B SERIES

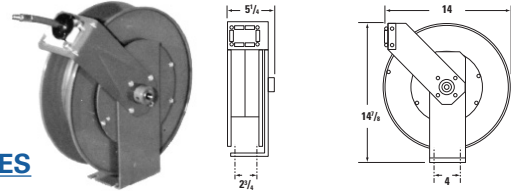

Other sizes, lengths and PSI available, ask one of our knowledgeable sales people.

# Hose Reels - C Series

The C Series - Low Pressure Reels are ideally suited for plant maintenance, service trucks and many other industrial functions where hose storage is a problem. Standard hose for air, water and light oils. Other hoses available upon request.

Hose Reel complete with 50' of 3/8" multi-purpose hose 300 PSI

**Part Number LC350 \*\***

*Inlet is 1/2" NPT  
Max. Temp - 200°F*

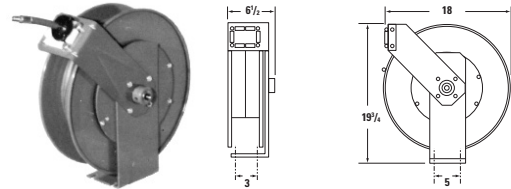

Contact DME for other available sizes, lengths and PSI.

### Universal Installation

The narrow size and a guide arm that can be easily rotated to any of the positions shown virtually solves all installation problems.

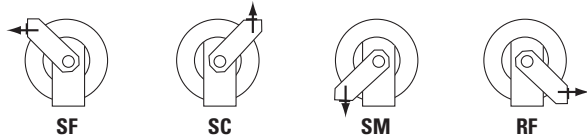

\*\* Reels are shipped in the SF position unless otherwise requested.

## HOSE REELS-C SERIES

# Nylon & Polyethylene Tubing

## NYLON & POLYETHYLENE TUBING

### Polyethylene Tubing (-40° to +135°F)

Part Number	Tubing		Burst Pressure	Wall Thick.	Box Quantity
	OD	ID			
PE44-100	1/4"	.170	500	.040	100
PE88-100	1/2"	.375	500	.062	100

- Good all-purpose tubing
- Extremely low cost
- Many plant uses

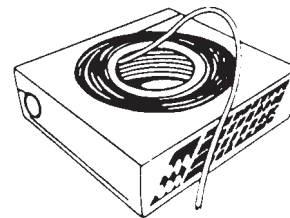

### Flexible Nylon Tubing (-60° to +250°F)

Part Number	Tubing		Burst Pressure	Wall Thick.	Box Quantity
	OD	ID			
NY44-100	1/4"	.215	1000	.035	100

- High burst pressure & temperature
- More flexible than standard nylon
- Bends tighter without kinking

# High Temperature Hose



## Extruded Silicone

Go to extremes...with Norflex Silicone High Temperature Hose! This hose is perfect for extremely high and low temperatures! Right at home in under-the-hood high temperatures, it remains flexible and maintains its seal in temperatures from -65 to 350°F (-54 to 177°C); the ultimate in low pressure hose. Norflex Silicone Hose meets your requirements for permanent plumbing. It delivers everything you've come to expect from silicone hose...and more!

- Excellent resistance to hardening and shrinking which is often the cause of leakage in hose
- Flexibility in extremely low temperatures helps guarantee long service in "as new" condition
- Because Norflex Silicone is unaffected by ozone, it breathes easily during long, hot summers
- Because it never cracks, it avoids costly shutdowns due to hose failure



Norflex Silicone

High Temp. Extruded Silicone Hose Meets & Exceeds All Performance Specs Of SAE J20 Part 3, SAE 20 R3 Class A

Part Number	Hose I.D.	Hose O.D.	Max. Working PSI Pressure	Burst PSI Pressure	Reel Length
NHC04	1/4"	.460"	85	125	250
NHC06	3/8"	.635"	80	125	250
NHC08	1/2"	.760"	80	125	250
NHC10	5/8"	.925"	70	125	250
NHC12	3/4"	1.070"	70	125	250

### HIGH TEMP HOSE

Be sure to use lined hose clamps with extruded hose (p. 481). \*Special order 500' reels.

## PTFE High Heat Hose Assemblies

- Hot oil hose
- RIM monomer mixing
- Low volumetric expansion
- Smooth, clean, high temperature
- +450° operating pressures to 3000 PSI

### PTFE HIGH HEAT HOSE

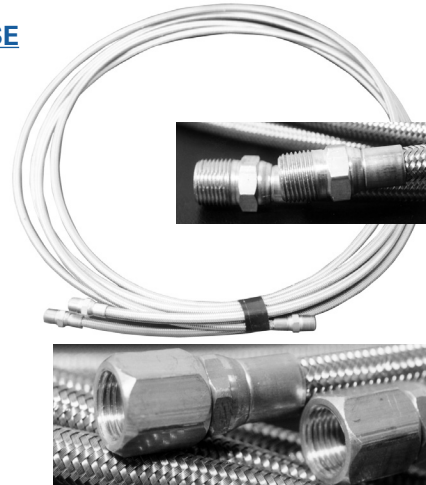

### Reference Dimensions

Nominal Hose I.D.	Actual I.D. (Inches)	Working Pressure	Burst Pressure	Min. Bend Radius
1/4"	.250	3000 PSI	12,000 PSI	2.0"
3/8"	.312	2500	10,000	4"
1/2"	.406	2000	8000	5.2"
3/4"	.625	1200	4800	7.7"

### With NPT Brass Male Fittings Swaged Onto Both Ends, Same As Hose Size

Length	1/4"	3/8"	1/2"	3/4"
4'	TH04-MP48	TH06-MP48	TH08-MP48	TH12-MP48
6'	TH04-MP72	TH06-MP72	TH08-MP72	TH12-MP72
8'	TH04-MP96	TH06-MP96	TH08-MP96	TH12-MP96
10'	TH04-MP120	TH06-MP120	TH08-MP120	TH12-MP120
12'	TH04-MP144	TH06-MP144	TH08-MP144	TH12-MP144

Female swivel JIC and stainless fittings are available; contact DME Industrial Supplies.





# PVC Air & Water Hose

- Choice of clear, red or blue
- Tough yet lightweight
- Very flexible
- Highly abrasion resistant
- Non-marking food grade PVC
- Resistant to most chemicals
- Good for water, air & mild chemicals
- Temperature range: -20° to 150°F (-5° to 65°C)

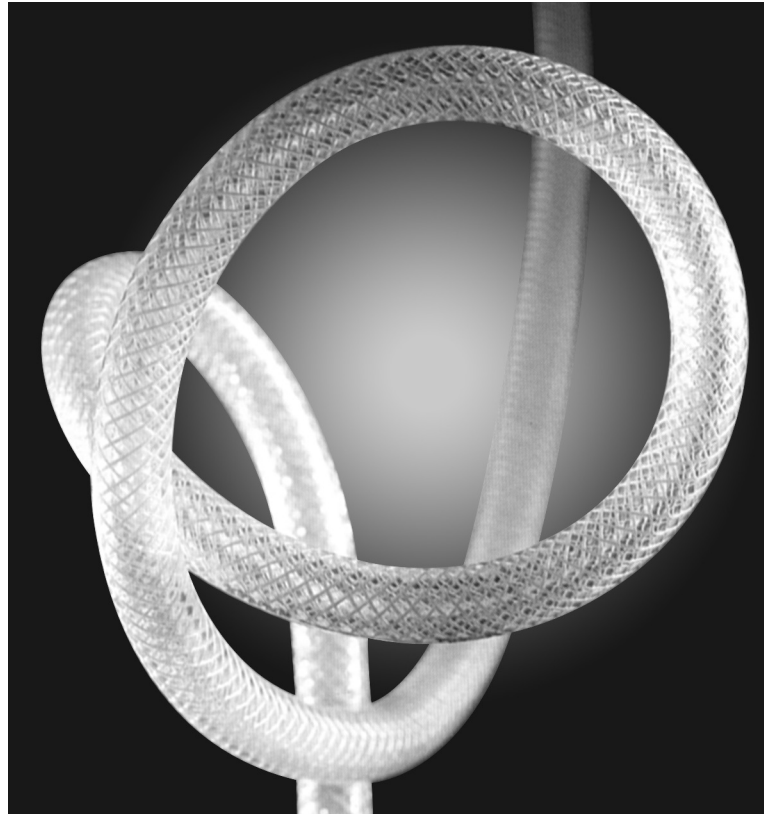
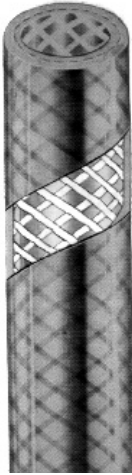

## 1125 PVC - Opaque Hose

Part Number						
Clear	Red	Blue	Inside Dia.	Outside Dia.	Working Pressure	Coil Length
1125-04	1125-04R	1125-04B	1/4"	.438	250 PSI	300 Ft.
1125-05	-	-	5/16"	.525		
1125-06	1125-06R	1125-06B	3/8"	.625	225 PSI	
1125-08	1125-08R	1125-08B	1/2"	.750	200 PSI	
1125-10	-	-	5/8"	.875	200 PSI	
1125-12	-	-	3/4"	1.025	150 PSI	200 Ft.
1125-16	-	-	1"	1.312	125 PSI	
1125-20	-	-	1 1/4"	1.656	100 PSI	100 Ft.
1125-24	-	-	1 1/2"	1.937	100 PSI	
1125-32	-	-	2"	2.500	75 PSI	

## PVC AIR & WATER HOSE

## Translucent Hose

Part Number	Color	Inside Diameter	Outside Diameter	Working Pressure	Coil Length
1125-06KR	Red	3/8"	5/8"	200 PSI	82 Ft
1125-06KB	Blue				
1125-08KR	Red	1/2"	3/4"		
1125-08KB	Blue				

## Polyurethane Recoil

- Extremely flexible - resists kinking
- Impervious to abrasion & heat
- Made with pigtails on coil - no need for whip hoses
- Less operator fatigue - low tension
- Superior elasticity & coil memory
- Special full flow fittings



The barb fittings used with our polyurethane hose are designed with this unique serrated gripping surface to hold the hose in place, especially under pressure.

### Polyurethane Recoil

Part Number	Hose Size	Male Swivel	Hose Length
PU04-10S	1/4"	1/4"	10'
PU04-15S	1/4"	1/4"	15'
PU04-25S	1/4"	1/4"	25'

### POLYURETHANE RECOIL

Both ends swivel.

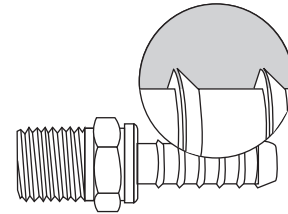

E



# 1400 Silicone Duct

## 1400 High Temperature Duct

- Fabric: Standard silicone impregnated fiberglass cloth
- Helix: Galvanized steel
- Available diameters: 2"-24"
- Standard length: 25'
- Temperature range: -65°F to 600°F
- Positive pressure: 20" W.G.
- Typical applications:
- High-temperature air, dust or fume control
- Resists alkalies, ozone & fungi

Available  
in 25'  
sections



1400 SILICONE DUCT

## "Adhesive-Free" Construction

The 1400 High Temperature Duct is manufactured by a mechanical process without the use of adhesives. This enables our standard ducts to operate at higher temperatures than conventional ducts because there is no worry of glue melting down or burning.

Part Number	Hose I. D.
1400-2	2"
1400-212	2½"
1400-3	3"
1400-4	4"

# 1500 Insulated Duct

## Service Conditions

A hose designed to move hot air from source to site of use, with minimal heat loss:

- Reduces heat loss/gain
- Clamps right to dryer take-off tube

Sold in  
12 foot

## Material

Outer: Polyester/Neoprene - U-Lok 100  
Inner: Silicone/Fiberglass - U-Lok 401

Construction: Mechanical bond, corrosion resistant

Size: 2" to 20" I.D. - larger sizes available

Bend radius: 2 x I.D.

Standard length: 12 ft. long

Weight: 6" I.D. = 2.1 lbs/ft.

Temperature range: - 65°F to 600°F

1500 INSULATED DUCT

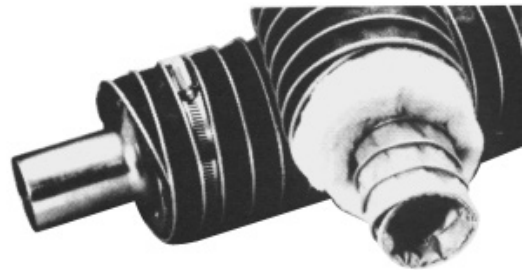

Part Number	Hose I. D.
1500-2	2"
1500-3	3"
1500-4	4"
1500-5	5"
1500-6	6"

# Silicone Dryer Hose



Silicone-coated fiberglass is highly resistant to extreme temperatures and is odor-free in hot air service. DME stocks most sizes listed below. We offer same-day shipping on most items... Isn't it time to replace that old, cracked and patched ducting?

- Choose single- or double- ply
- Non-kicking, lightweight
- Industry standard product!
- Best selection of sizes, lowest prices!
- Orange cover

**Sold in 12 foot sections**  
*(except where noted)*



## SILICONE DRYER HOSE

### Single-Ply Silicone Duct — Rated to 600° F (500° continuous)

Part Number	Hose I. D.	Working Pressure	Stock Length
NSD1-2	2"	10	12'
NSD1-212	2½"	10	12'
NSD1-3	3"	10	12'
NSD1-5	5"	6	12'
NSD1-6	6"	4	12'
NSD1-8	8"	3	12'

Other sizes by request. 20' lengths may be available in other sizes but are not stocked.

Hose sold only in lengths of 12' or 20' as listed in last column.

### Double-Ply Silicone Duct — Rated to 600° F (500° continuous)

Part Number	Hose I. D.	Stock Length	Working Pressure
NSD2-114	1¼"	12'	60
NSD2-112	1½"	12'	55
NSD2-134	1¾"	12'	55
NSD2-2	2"	12'	50
NSD2-212	2½"	12'	45
NSD2-3	3"	12'	45
NSD2-4	4"	12'	40
NSD2-5	5"	12'	35
NSD2-6	6"	12'	30

Other sizes on request.

**Sold in 12 foot sections**  
*(except where noted)*





# NND Return Air Duct

## Neoprene Duct

- Rated to 350°F
- Perfect for return air or low-temp dryer
- Single-ply stocked - double-ply from factory; contact DME



NND RETURN AIR DUCT

**Sold in  
12 foot  
sections**

Part Number	Hose I. D.	Stock Length
NND112	1½"	12'
NND134	1¾"	12'
NND2	2"	12'
NND212	2½"	12'
NND3	3"	12'
NND4	4"	12'
NND5	5"	12'
NND6	6"	12'

Thread hoses together for longer lengths.

## High Performance Hose

Series 1180 High Performance Hose is ideally suited for the transfer of pellets, granules and other abrasive materials.

This hose features a heavy-wall tube made of urethane, a resilient material known for its abrasion resistance and long-term performance under demanding conditions. A rigid PVC helix provides reinforcement.

With helix wrapped around the outside diameter of hose, a "bearing" surface is created which makes it easy to drag hose across concrete and other rough surfaces.

Series 1180 Urethane Hose is much lighter than conventional suction hoses. It is very flexible and easy to handle. This hose maintains its flexibility at sub-zero temperatures which adds to its versatility.

Construction: Clear urethane tube; white PVC helix cover

Temperature Range: -4° to +150°F



HIGH PERFORMANCE HOSE

Part Number	Inside Diameter	Outside Diameter	Bend Radius	Working PSI at 72°
1180-24	1½"	1.85	3.8"	30
1180-32	2"	2.50	5.5"	25
1180-40	2½"	3.00	7.0"	20
1180-48	3"	3.60	8.0"	20

**Sold in  
25 foot  
sections**

# Vacuum Loader Hose



- FDA approved for food service
- Tough, yet very flexible
- Abrasion resistant
- Smooth bore - low friction loss
- Clear for visual inspection
- Temperature range:  
-4° to 150°F (-20° to 66°C) - static conditions  
14° to 104°F (-10° to 40°C) - dynamic conditions

Sold in  
25 foot  
sections



Sizes up to and including 2½" ship  
UPS, anything larger goes LTL

Part Number	Inside Diameter	Vacuum Rating At 68°F Hg	Minimum Bend Radius	O.D. Size	Max. W.P. At 68°F	Weight Lbs/Ft
1175-16	1"	28"	3"	1¼"	60 PSI	.19
1175-20	1¼"	28"	3"	1½"	50 PSI	.29
1175-24	1½"	28"	3"	1⅞"	50 PSI	.34
1175-28	1¾"	28"	3½"	2⅛"	45 PSI	.40
1175-32	2"	28"	4"	2 <sup>13</sup> / <sub>16</sub> "	45 PSI	.50
1175-35	2 <sup>3</sup> / <sub>16</sub> "	28"	4"	2 <sup>9</sup> / <sub>16</sub> "	40 PSI	.57
1175-36	2¼"	28"	5"	2 <sup>21</sup> / <sub>32</sub> "	40 PSI	.63
1175-40	2½"	28"	6"	2 <sup>29</sup> / <sub>32</sub> "	40 PSI	.77
1175-48	3"	28"	8"	3½"	35 PSI	1.02
1175-64	4"	28"	10"	4 <sup>5</sup> / <sub>8</sub> "	35 PSI	1.64

## VACUUM LOADER HOSE

# Vacuum Grounded Loader Hose

- Grounded safety
- Static ground wire - full length
- Smooth bore, very flexible
- For pellets, powders & granules
- Static conditions: -4°F to 150°F
- Dynamic conditions: 14°F to 104°F
- Choose cut length or full roll

Sold in  
25 foot sections  
(except as noted\*)



## VACUUM GROUNDED

### Lightweight, Flexible Economy Style - Caution: Not for use with high-abrasive applications

Part Number	Inside Diameter	Vacuum Rating At 68°F Hg	Minimum Bend Radius	Max. W.P. At 68°F
1175G24	1½"	28"	3.2"	50 PSI
1175G28	45MM (1¾")	28"	3.2"	40 PSI
1175G32	2"	28"	3.2"	40 PSI
1175G40	2½"	28"	4.5"	35 PSI

### Heavy, More Durable Style

Part Number	Inside Diameter	Vacuum Rating At 68°F Hg	Minimum Bend Radius	Max. W.P. At 68°F
H1175G20	1¼"	28"	5"	50
H1175G24	1½"	28"	5"	50
H1175G28 *	1¾"	28"	5"	45
H1175G32	2"	28"	5"	40
H1175G40	2½"	28"	6"	40

\* 60 foot section





# Metal Loader Hose

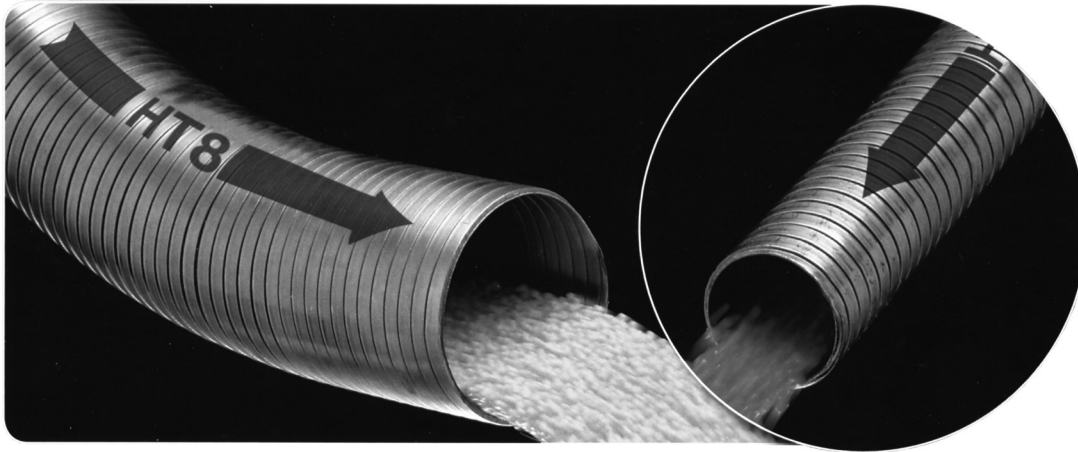

HT5000 Interlocked Metal Hose combines the Hose Tec® single-strip interlocking construction with a smooth liner, providing a flexible metal hose that resists material buildup and internal abrasion. Materials flow smoothly in direction shown by arrows.

## Construction

- An armor strip is combined with a strip of liner material and formed to create a lined, flexible, interlocked metal hose that offers superior strength and abrasion-resistance.

## Applications

- Railcar offloading
- Pneumatic dry bulk unloading of grains, pellets, powders and dry chemicals
- Ideal hose for general bulk unloading applications
- Transfer of hot materials (not for hot tar or asphalt)
- Bulk unloading of highly abrasive materials
- Plastic pellet transfer

## Features

- Flow indication arrows are provided on each length
- Stainless steel liner provides additional strength and greater resistance to abrasion
- Smooth liner reduces material degradation and improves unloading time
- Provides maximum flow rates for pneumatic conveying applications
- Available in standard 25' lengths

## Maximum Service Temperature

- Series 300 stainless steel: up to 1500°F

### [METAL LOADER HOSE](#)

Part Number	Description
HTSS150	1½" Metal Vacuum Loader Hose
HTSS175	1¾" Metal Vacuum Loader Hose
HTSS200	2" Metal Vacuum Loader Hose
HTSS225	2¼" Metal Vacuum Loader Hose
HTSS250	2½" Metal Vacuum Loader Hose
HTSS300	3" Metal Vacuum Loader Hose
HTSS350	3½" Metal Vacuum Loader Hose
HTSS400	4" Metal Vacuum Loader Hose
HTSS500	5" Metal Vacuum Loader Hose
HTSS600	6" Metal Vacuum Loader Hose

# Oetiker 1 & 2 Ear Clamps



- No retightening needed
- Install quickly
- Allows tight installations
- No clamp creeping



1-Ear Clamps  
smaller range,  
thinner  
Low price!!



2-Ear Clamps  
large range,  
thicker  
Low price!



## EAR CLAMPS

### 1 Ear Clamp

**\*100 pieces per bag**

Zinc Plated Part Number	Stainless Steel Part Number	Clamp Range (mm) Closed – Open	Clamp Range (inches) Closed – Open
EC105	ECS105	8.9 – 10.5	0.350 – 0.413
EC113	ECS113	9.7 – 11.3	0.382 – 0.445
EC123	ECS123	10.4 – 12.3	0.409 – 0.484
EC133	ECS133	11.4 – 13.3	0.449 – 0.524
EC145	ECS145	12.6 – 14.5	0.496 – 0.571
EC157	ECS157	13.5 – 15.7	0.531 – 0.618
EC170	ECS170	15.1 – 17.0	0.594 – 0.669
EC185	ECS185	15.7 – 18.5	0.618 – 0.728
EC198	ECS198	17.0 – 19.8	0.669 – 0.780
EC210	ECS210	18.2 – 21.0	0.717 – 0.827
EC226	ECS226	19.8 – 22.6	0.780 – 0.890
EC241	ECS241	21.3 – 24.1	0.839 – 0.949
EC256	ECS256	22.8 – 25.6	0.898 – 1.008
EC271	ECS271	24.0 – 27.1	0.945 – 1.067
EC301	ECS301	27.0 – 30.1	1.063 – 1.185
EC331	ECS331	30.0 – 33.1	1.181 – 1.303
EC361	ECS361	33.0 – 36.1	1.299 – 1.421
EC381	ECS381	35.0 – 38.1	1.378 – 1.500

### 2 Ear Clamp

**\*100 pieces per bag**

Zinc Plated Part Number	Stainless Steel Part Number	Clamp Range (mm) Closed – Open	Clamp Range (inches) Closed – Open
EC0709	ECS0709	7.0 – 9.0	0.276 – 0.354
EC0811	ECS0811	8.1 – 11.0	0.319 – 0.433
EC1113	ECS1113	8.0 – 11.0	0.315 – 0.433
EC1315	ECS1315	10.8 – 13.0	0.425 – 0.512
EC1517	ECS1517	11.0 – 13.0	0.433 – 0.512
EC1518	ECS1518	12.5 – 15.0	0.492 – 0.591
EC1720	ECS1720	14.0 – 17.0	0.551 – 0.669
EC1922	ECS1922	15.0 – 18.0	0.591 – 0.709
EC2023	ECS2023	16.2 – 20.0	0.638 – 0.787
EC2225	ECS2225	18.0 – 22.0	0.709 – 0.866
EC2327	ECS2327	18.1 – 22.0	0.713 – 0.866
EC2528	ECS2528	19.0 – 23.0	0.748 – 0.906
EC2731	ECS2731	19.1 – 23.0	0.752 – 0.906
EC3134	ECS3134	21.0 – 25.0	0.827 – 0.984
EC3437	ECS3437	21.1 – 25.0	0.831 – 0.984
EC3740	ECS3740	22.5 – 27.0	0.886 – 1.063
		24.0 – 28.0	0.945 – 1.102
		26.3 – 31.0	1.035 – 1.220
		29.3 – 34.0	1.154 – 1.339
		32.0 – 37.0	1.260 – 1.457
		35.0 – 40.0	1.378 – 1.575

E



# Stainless Hose Clamps

Tridon®

## TRIDON

Standard 100% Stainless Hose Clamps

### SHC Clamps

- Unique interlocking design
  - One-piece housing & band
  - Slotted carbon chromate plate
- Clamp Materials

- Band - 1/2" 301 stainless
- Housing - 301 stainless



STAINLESS HOSE CLAMP

Part Number	Diameter Range	
	Min.	Max.
SHC6	3/8	7/8
SHC8	7/16	1
SHC10	1/2	1-1/16
SHC12	1/2	1-1/4
SHC16	11/16	1-1/2
SHC20	3/4	1-3/4
SHC24	1	2
SHC28	1-1/4	2-1/4
SHC32	1-1/2	2-1/2
SHC36	1-3/4	2-3/4
SHC40	2	3
SHC44	2-1/4	3-1/4
SHC48	2-1/2	3-1/2
SHC52	2-3/4	3-3/4
SHC56	3	4
SHC60	3-1/4	4-1/4
SHC64	2-1/2	4-1/2
SHC72	3	5
SHC80	3-1/2	5-1/2
SHC96	4-1/2	6-1/2
SHC104	5	7
SHC152	7-1/8	10
SHC188	12-1/4	12-1/4

## Miniature Stainless Hose Clamps

### MSC Clamps

- Easy to install in confined areas
- Hold tough in tight spots

### Clamp Materials

- Band - 5/16" 301 stainless
- Housing - 301 stainless
- Screw 1/4" 410 stainless hex head

Part Number	Diameter Range	
	Min.	Max.
MSC04	1/4	5/8
MSC06	5/16	7/8
MSC08	3/8	1
MSC10	3/8	1-1/16
MSC12	1/2	1-1/4

MINI HOSE CLAMP

## Lined Stainless Hose Clamps

### LHC Clamps

- Use for soft hose of any type
- Use for all silicone hoses
- Liner prevents extrusion of thru screw notches

### Clamp Materials

- Band - 5/16" 301 stainless
- Housing - 301 stainless

Part Number	Diameter Range	
	Min.	Max.
LHC6	5/8	7/8
LHC8	5/8	1
LHC10	3/4	1-1/16
LHC12	7/8	1-1/4
LHC16	1	1-1/2
LHC20	1-1/8	1-3/4

LINED HOSE CLAMP

# Stainless Hose Clamps



## Kuri-Clamp™ Worm Gear Clamps



[KURI CLAMP](#)



### Stainless Hose Clamps

#### Heavy-Duty Worm Gear

Stainless Steel Band & Housing with Carbon steel screw

#### General Applications:

- Small Diameter applications
- Air & water lines

#### Construction: Four-piece construction consisting of:

- 9/16" wide. 300 series stainless steel band
- Plated carbon steel hex screw with 5/16 head.
- 300 series stainless steel housing.

Part Number	Diameter Range	
	Min.	Max.
WHCCSHD06	7/16	25/32
WHCCSHD08	1/2	29/32
WHCCSHD10	9/16	1-1/16
WHCCSHD12	11/16	1-1/4
WHCCSHD20	13/16	1-3/4
WHCCSHD24	1-1/16	2
WHCCSHD28	1-5/16	2-1/4
WHCCSHD32	1-9/16	2-1/2
WHCCSHD36	1-13/16	2-3/4
WHCCSHD40	2-1/16	3
WHCCSHD44	2-5/16	3-1/4
WHCCSHD48	2-9/16	3-1/2
WHCCSHD104	4-1/8	7
WHCCSHD188	9-3/8	12-1/4

### Mini Worm Gear

Stainless Steel Band & Housing with Carbon steel screw

#### General Applications:

- Small Diameter applications
- Air & water lines

#### Construction: Three-piece construction consisting of:

- 5/16" wide. 300 series stainless steel band
- Plated carbon steel hex screw with 1/4" head
- One-piece 300 series stainless steel housing



Part Number	Diameter Range	
	Min.	Max.
WHCMCS04	7/32	5/8
WHCMCS06	7/16	25/32
WHCMCS08	1/2	29/32
WHCMCS10	9/16	1-1/16
WHCMCS12	11/16	1-1.4





# Stepless Ear Clamp

The term “stepless” refers to the absence of steps or gaps on the circumference of the clamp. The stepless design of the Stepless Ear Clamp provides uniform compression and a 360° seal. The unique “tongue-in-groove” design was developed to assure that the inner circumference is free of steps or gaps that could be detrimental to the sealing ability of the clamp.

The groove is extruded 1x material thickness on the outer surface and is approximately 1/3 the band width; the mating tongue provides a uniform inner circumference. During the clamp closing process, the tongue engagement increases in the groove, minimizing the reduced surface area, ensuring uniform compression or surface pressure over the full 360° of the assembled parts.

- Stainless steel band UNS S 30400 or Din 1.4301
- 360° stepless design - no steps or gaps on the inner circumference
- Narrow band, concentrated seal compression
- Smooth-edged band steel prevents damage to hose
- Lightweight
- Tamper detectable design



## STEPLESS EAR CLAMP

Part Number	Size Ref. (mm)	Clamp Range (mm)		Clamp Range (inches)	
		Closed	Open	Closed	Open
SEC145	14.5	12.0	14.5	0.472	0.571
SEC153	15.3	12.8	15.3	0.504	0.602
SEC157	15.7	13.2	15.7	0.520	0.618
SEC162	16.2	13.7	16.2	0.539	0.638
SEC17	17.0	14.5	17.0	0.571	0.669
SEC185	18.5	15.3	18.5	0.602	0.728
SEC198	19.8	16.6	19.8	0.654	0.780
SEC21	21.0	17.8	21.0	0.701	0.827
SEC226	22.6	19.4	22.6	0.764	0.890
SEC235	23.5	20.3	23.5	0.799	0.925
SEC241	24.1	20.9	24.1	0.823	0.949
SEC256	25.6	22.4	25.6	0.882	1.008
SEC271	27.1	23.9	27.1	0.941	1.067

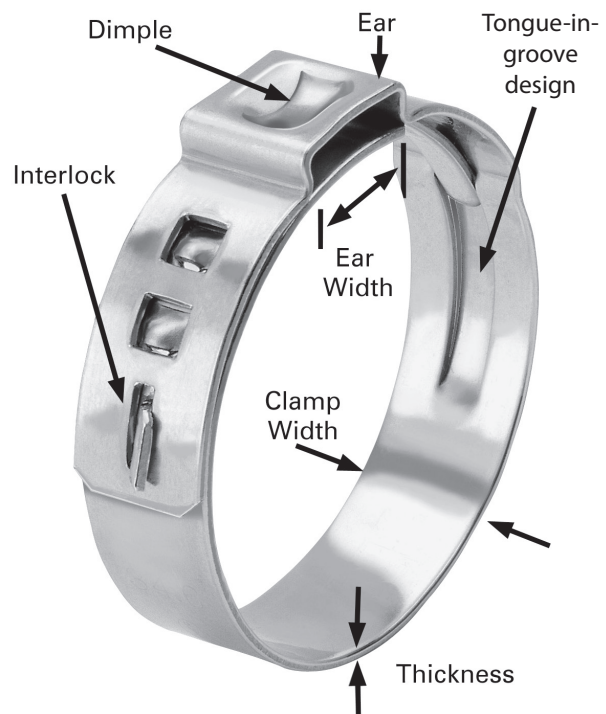



# Pincers & Service Kits



**Service Kits - Zinc-Plated, 2-Ear Clamps**  
 Kit number SK1098 - contains model 1098I pincers & clamps listed below. Low cost - handy!

## SK-1098

Kits contain 15 of each of the following zinc-plated 2-Ear Clamps:  $\frac{5}{16}$ " ,  $\frac{7}{16}$ " ,  $\frac{1}{2}$ " ,  $\frac{9}{16}$ " ,  $\frac{5}{8}$ " ,  $\frac{3}{4}$ " ,  $\frac{7}{8}$ " ,  $\frac{15}{16}$ " , & 1"



## PINCERS & SERVICE KITS

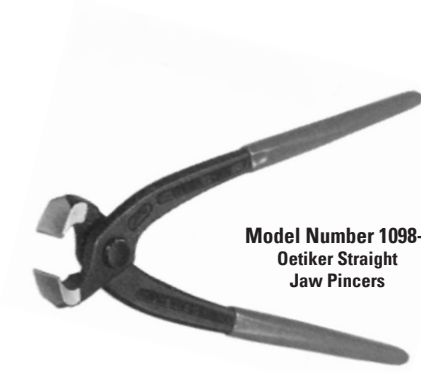

Model Number 1098-I  
 Oetiker Straight  
 Jaw Pincers

**Great for  
 confined areas!**



Model Number 1099-I  
 Oetiker Side  
 Jaw Pincers

## Installation:



When installing Oetiker Ear Type Clamps, please note that each ear must be crimped as recommended to obtain a proper seal. An incorrectly made installation may impair the best connection. If a clamp ear can be closed all the way, the clamp size selected is probably too big and the next smaller clamp should be ordered.

### How to Apply:

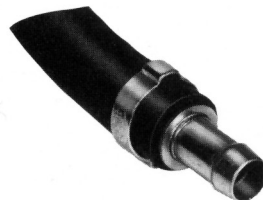

Position clamp on hose as illustrated.

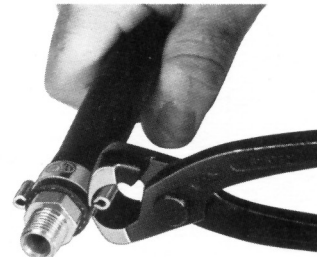

Give each ear a firm squeeze with your Oetiker Pincers.

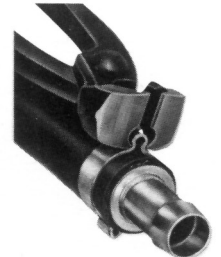

Where access to ear is difficult use Oetiker Side Jaw Pincers #1099-I.

### How to

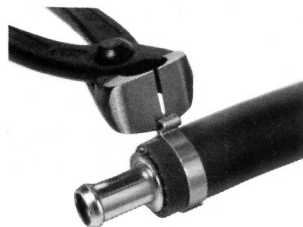

Grip the outer edge of ear firmly and cut through it with either pincers.



Cut the ear by taking several small bites at its base with either pincers.

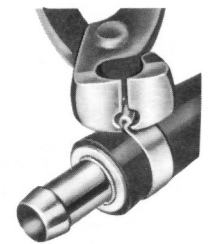

Then grip ear firmly and twist it off.







# T-Clips

T-Clips provide a quick, adaptable and inexpensive answer to securing, attaching and routing of tubes, wires, hose and pipe.

T-Clips provide an exact uniform spacing to dual runs and can be mounted on walls, cabinets, boards, enclosures and bulkheads. T-Clips are available in a wide range of sizes.

A countersunk centerhole is provided in each T-Clip for the fastener of your choice.

T-Clip Number	Spacer Number	Fits Hose O.D.	
		From	To
T4	-	5/32	1/4
T6	-	1/4	5/16
T8	D8	5/16	3/8
T10	D10	3/8	1/2
T12	D12	1/2	5/8
T15	D15	5/8	3/4
T18	D18	3/4	7/8
T22	D22	7/8	1"

## T-CLIPS



1. Place open sides of T-Clip between tubes.



2. Snap T-Clip onto tubes with a quick quarter turn.



3. T-Clip is ready for mounting with tubes held in uniform spacing.

# Heli-Tube® Hose & Wire Wrap

## Heli-Tube®

### Spirally Cut Wrap

- Protects hose from abrasion
- Can be applied with hose in place
- U.V. resistant
- Low cost, great value!

### Specifications:

- Temperature range: -105°F to +190°F
- Abrasion resistance - M6 loss per M cycles: 20
- Di-Electric constant T-D-50: 2.6
- Tensile strength @ 73°F-D-412-51T PSI: 1800
- Specific gravity - D792-50: 0.93
- Material: polyethylene



### HELI-TUBE HOSE & WIRE WRAP

Part Number	Size Range Dia.*	Nom. O.D.	Wall	Spool Length
HT18C	1/16 to 1/2"	1/8"	.032	100'
HT316C	1/4 to 1 1/2"	3/16"	.031	100'
HT14C2	3/16 to 2"	1/4"	.035	100'
HT38C	5/16 to 3"	3/8"	.052	100'
HT34C	3/4 to 5"	3/4"	.065	100'
HT1C	1 to 7"	1"	.095	100'

\*Sizes are tight - order larger than actual size needed.