

HPS9999

09-08

ME-0739-PS-433-B

DME

INSTALLATION DATA

FOR HP-SERIES STRAIGHT SHOTS

PLEASE READ CAREFULLY BEFORE INSTALLING COMPONENTS

HP-Series Straight Shot "S" Type

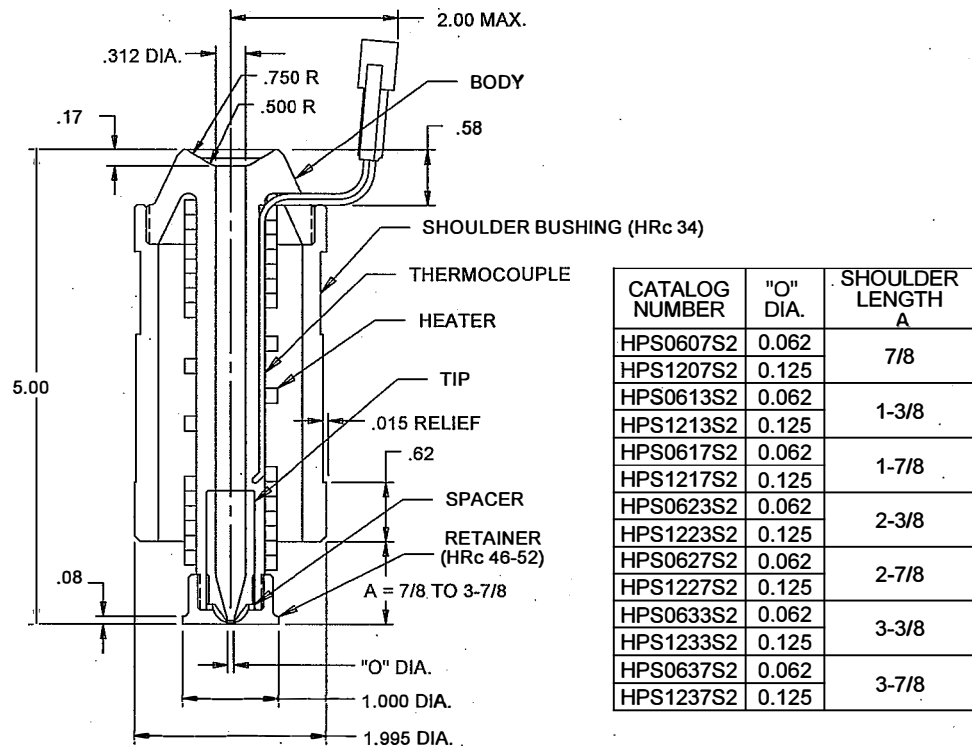

REPLACEMENT PARTS

NOTE: DIMENSIONS ARE IN INCHES

ASSEMBLY CAT. NO.	BODY CAT. NO.	SHOULDER BUSHING CAT. NO.	TIP CAT. NO.	RETAINER CAT. NO.	SPACER CAT. NO.	HEATER CAT. NO.	THERMOCOUPLE CAT. NO.
HPS0607S2	HPS0001	HPS1007	HPT0001	HPT0601	HPT1001	HPS2001	HPTS3001
HPS0613S2		HPS1013					
HPS0617S2		HPS1017					
HPS0623S2		HPS1023					
HPS0627S2		HPS1027					
HPS0633S2		HPS1033					
HPS0637S2		HPS1037					
HPS1207S2		HPS1007					
HPS1213S2	HPS1013						
HPS1217S2	HPS1017						
HPS1223S2	HPS0001	HPS1023	HPT0002	HPT1201	HPT1001	HPS2001	HPTS3001
HPS1227S2		HPS1027					
HPS1233S2		HPS1033					
HPS1237S2		HPS1037					

D-M-E SHALL NOT BE LIABLE FOR MISUSE OR FAILURE TO FOLLOW THE ENCLOSED INSTRUCTIONS AND SPECIFICATIONS. D-M-E HERBY TO DISCLAIM ALL IMPLIED WARRANTIES, INCLUDING MERCHANTABILITY AND FITNESS FOR A PARTICULAR PURPOSE. IN NO EVENT SHALL D-M-E BE RESPONSIBLE FOR LOSS OF USE, REVENUE OR PROFIT, OR FOR INCIDENTAL OR CONSEQUENTIAL DAMAGES.

HP-Series Straight Shot "E" Type

< "E" TYPE RETAINER MUST BE MODIFIED >

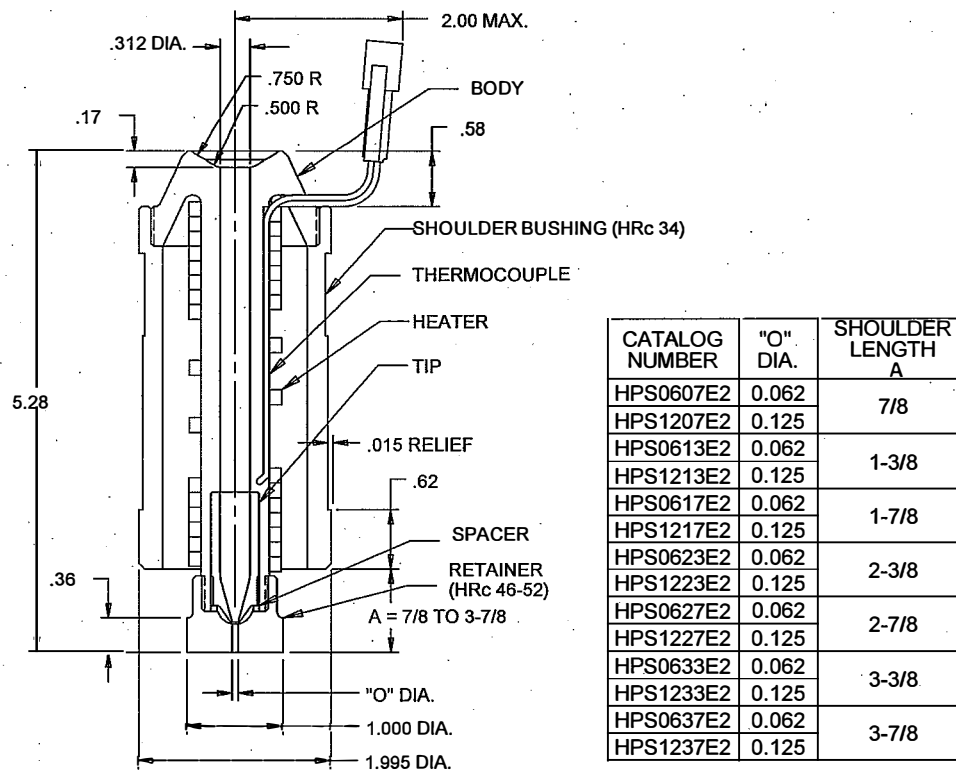

REPLACEMENT PARTS

ASSEMBLY CAT. NO.	BODY CAT. NO.	SHOULDER BUSHING CAT. NO.	TIP CAT. NO.	RETAINER CAT. NO.	SPACER CAT. NO.	HEATER CAT. NO.	THERMOCOUPLE CAT. NO.
HPS0607E2	HPS0001	HPS2007	HPT0001	HPT0602	HPT1001	HPS2001	HPTS3001
HPS0613E2		HPS2013					
HPS0617E2		HPS2017					
HPS0623E2		HPS2023					
HPS0627E2		HPS2027					
HPS0633E2		HPS2033					
HPS0637E2		HPS2037					
HPS1207E2		HPS2007					
HPS1213E2	HPS2013						
HPS1217E2	HPS2017						
HPS1223E2	HPS0001	HPS2023	HPT0002	HPT1202	HPT1001	HPS2001	HPTS3001
HPS1227E2		HPS2027					
HPS1233E2		HPS2033					
HPS1237E2		HPS2037					

Design Guidelines For Altering "S" AND "E" Type Bushings

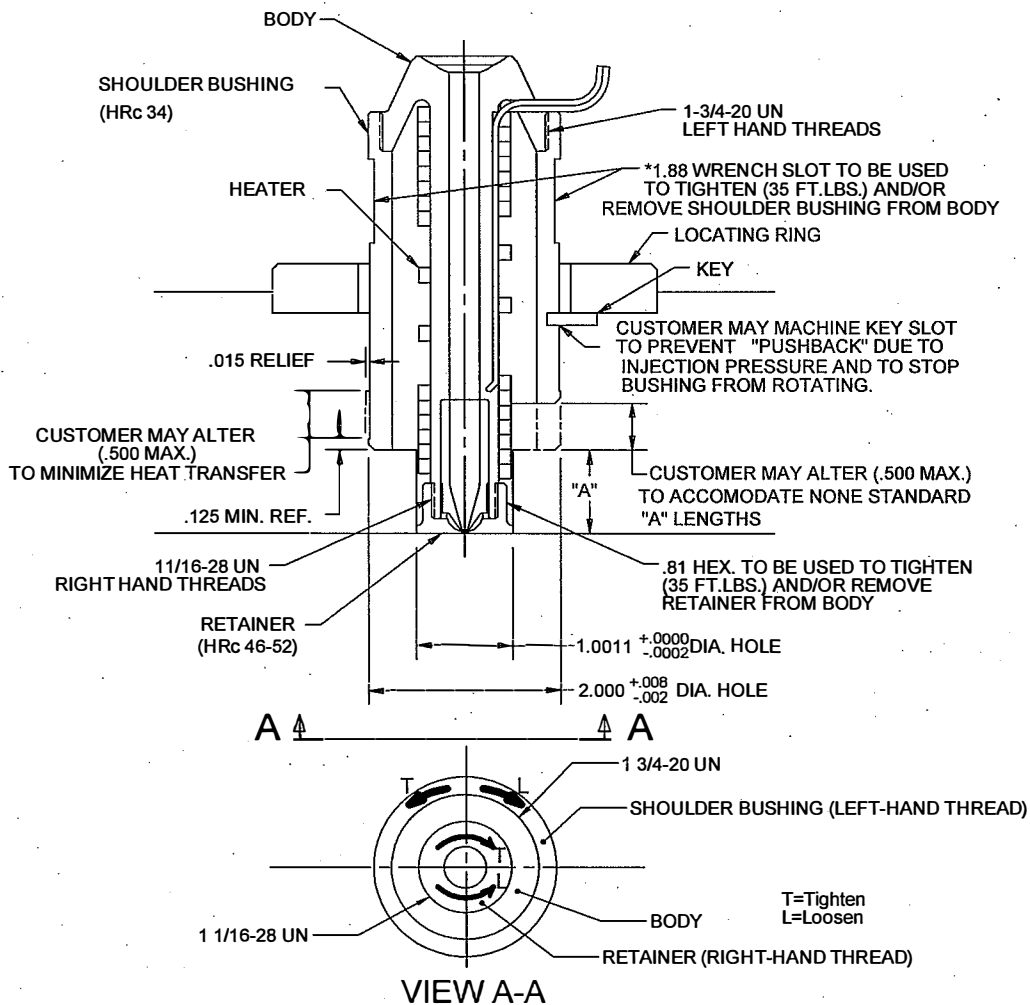

Design Guidelines For Altering "E" Type Bushing Retainer

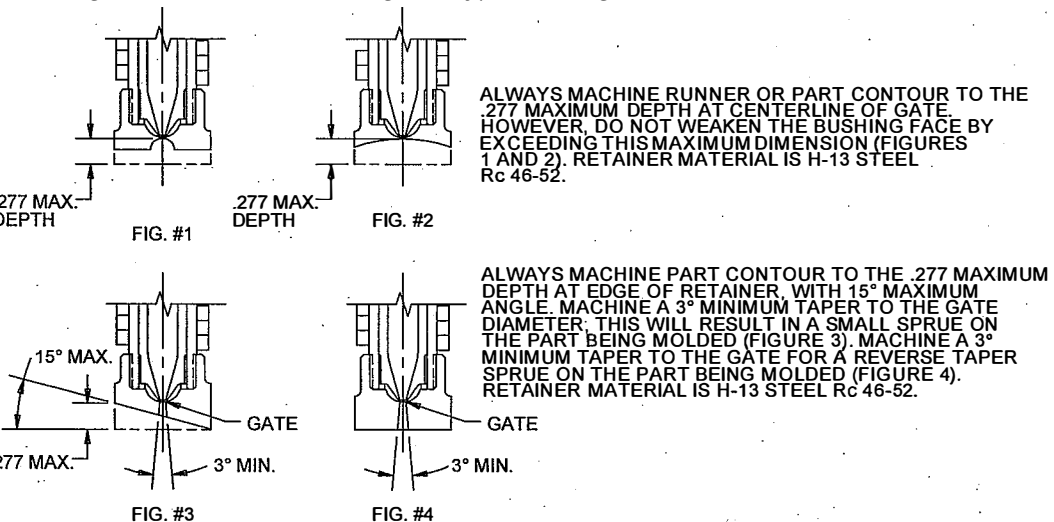

Guidelines And Recommendations:

1. BUSHING BODY SHOULD BE CLEANED OF ANY MATERIAL IN SPH. RAD. AND THREADED AREAS BEFORE REASSEMBLING. SHOULDER BUSHING THREAD IS "LEFT-HAND".
2. CAUTION ATTENTION SHOULD BE TAKEN NOT TO DAMAGE TIP. TREAT TIP LIKE A GLASS OR CERAMIC MATERIAL.
3. DO NOT LUBRICATE OR USE ANTI-SEIZE ON THREADS.
4. RETAINER MUST BE TORQUED ONTO THE BUSHING BODY USING A TORQUE WRENCH AT 35 FT-LBS (RETAINER HAS A .81 HEX.). RETAINER THREAD IS "RIGHT-HAND".
5. "E" TYPE RETAINER MUST BE MODIFIED AND SHOULD BE REMOVED FROM THE BODY BEFORE MACHINING RUNNER OR PART CONTOUR INTO RETAINER. SEE DESIGN GUIDELINES FOR ALTERING "E" TYPE BUSHING RETAINER. WHEN MACHINING IS COMPLETE, REASSEMBLE RETAINER ONTO BUSHING BODY USING SPECIFIED TORQUE (SEE NOTE #4).
6. THE THERMAL EXPANSION FACTOR SHOULD BE CONSIDERED PRIOR TO ASSEMBLING THE BUSHING INTO THE MOLD.
7. WHEN HANDLING BUSHING, USE CAUTION AS TO NOT DAMAGE HEATER AND THERMOCOUPLE LEADS.
8. WAIT A MINIMUM OF 5 MINUTES AFTER SET POINT HAS BEEN ACHIEVED FOR SUFFICIENT HEAT TO TRANSFER INTO THE TIP BEFORE MOLDING.
9. ALWAYS USE A CLOSED LOOP HEATER ON THE MACHINE NOZZLE TIP AND PLACE AS CLOSE TO THE BUSHING RADIUS END AS POSSIBLE.
10. PROVIDE MAXIMUM WATER COOLING IN THE "A" PLATE AND/OR CAVITY INSERT AROUND GATE.
11. ROUTE WIRES THROUGH MACHINE PLATEN AND TO DME CONTROLLER.
12. HEATER IS 700 WATTS / 240 VOLTS AND LEADS ARE 5 DEG FROM CENTERLINE.
13. THERMOCOUPLE IS 5 DEG FROM CENTERLINE.

IMPORTANT SAFETY INFORMATION

A hot-runner system includes electrical elements and may contain molten plastic at elevated temperature and pressure. To avoid injury, exercise caution by reading these instructions before servicing or operating the system.

These instructions must be passed on to the end user where they should be read before using this product. Failure to do so can result in serious injury or death.



Failure to comply will result in serious injury or death:

ELECTRICAL HAZARDS

Improper voltages or grounding can result in electrical shock. Use only with proper voltage and a proper earth ground.

To avoid electrical shock, do not operate product when wet.

Do not operate this equipment with covers or panels removed.

To avoid electrical shock, turn off main power disconnect and lockout / tag out before servicing this device. Do not connect temperature sensors to electrical power. It will damage the product and it can cause fire, severe injuries or even death.

If green ground wire present wire must be connected to the ground.

Do not bend rigid leads. Rebending leads might result in damage to circuit. Product might absorb moisture when cool. Use low Voltage or power to drive out residual moisture before applying full power. Failure to do so may cause damage to this product.



Failure to comply can result in serious injury or death:

STORED ENERGY AND HIGH TEMPERATURE HAZARDS

This product maintains molten plastic at high pressure. Use caution when operating and servicing the system.

Physical contact with molten plastic may result in severe burns. Proper protective equipment, including eye protection, must be worn. This product has heated surfaces. Use caution when operating and servicing the system to avoid severe burns. Proper protective equipment should be worn.

WIRING INFORMATION

Square Coil Heaters are supplied with 50" long leads, 24 gage.

Heaters are 240 VAC.

2 power leads are BLACK or MULTI COLOR

1 ground lead is GREEN, 24 Gage.

Thermocouples are "J" Type.

Thermocouples are supplied with:

1 T/C lead is WHITE and negative (-) constantan (non-magnetic).

1 T/C lead is BLACK and positive (+) iron (magnetic).

DME COMPANY

29111 STEPHENSON HIGHWAY
MADISON HEIGHTS
MICHIGAN 48071 USA

US 800-626-6653

CANADA 800-387-6600

www.dme.net