



Custom Pins and Sleeves – Faxable Quote Form

Email Completed form to: dme@dme.net

QUOTE FAX HOTLINES AVAILABLE

United States: 888-808-4363 • Canada: 800-461-9965 • International: 248-398-7394

Custom Pins

Quantity: _____

Choose a pin type:

EX (35–43 HRC core hardness with 65–70 HRC case hardness)

THX (50 HRC–55 HRC core hardness with 65–70 HRC case hardness)

CX (50–55 HRC through hard)

C (30–35 HRC through hard)

Material H-13:

Other _____

Hardness _____ RC

Nitrided: Yes No

Comments _____

Tolerances: Std Other (provide)

Custom Sleeves

Quantity: _____

Nitride on OD (S)

Nitride on OD + ID (SND)

Material H-1:

Other _____

Hardness _____ RC

Comments _____

Straight Pin

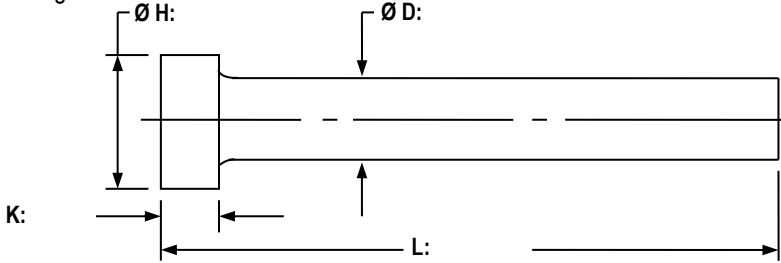

Step Pin

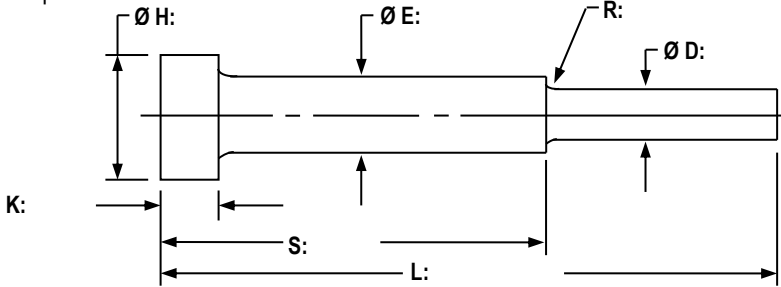

Sleeve

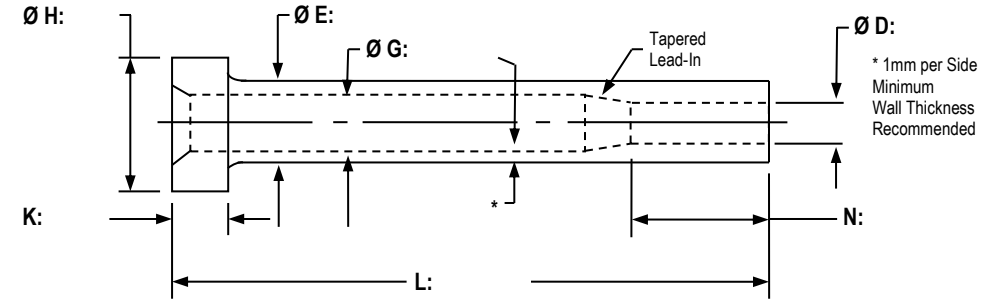

Step Sleeve

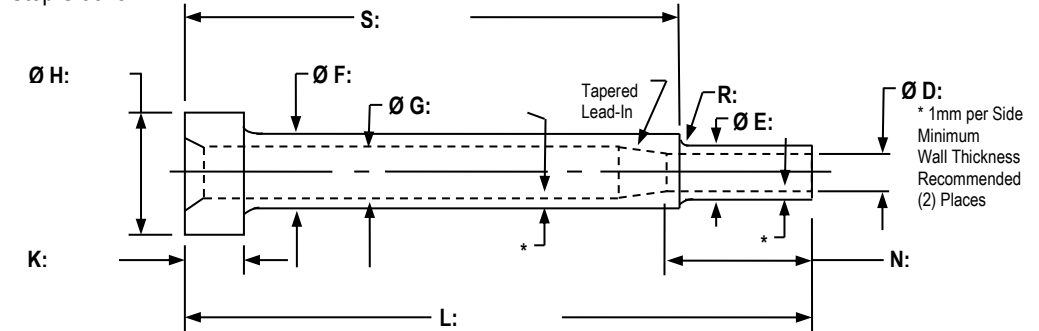

Company name: _____

Contact name: _____

Phone: _____

Address: _____

City: _____

ZIP/Postal Code: _____

DME account #: _____

P.O. #: _____

FAX: _____

E-mail: _____

State/Province: _____

Country: _____

Shipping method:

- UPS Ground
- UPS 2nd Day Air
- UPS Next Day
- FedEx
- Other