

COLLAPSIBLE
DME CORE



DME S-CORE Collapsible Core

PREMIUM UNDERCUT SOLUTION
THE NEXT LEVEL OF PERFORMANCE

DME S-CORE TYPES

AN ADVANCED SOLUTION TO MOLDING THREADS AND UNDERCUTS

More options more capabilities. The New DME S-Core is a dynamic design that can be produced in 6, 8 or 12 segments enabling parts to be produced as small as 6mm and as large as 400mm. The length and depth of the part feature dictates the number of segments required to release the undercut.

DME Engineers will review each part model and design a DME S-Core for your specific application. Each DME S-Core utilizes **patented safety stops** preventing the folding segments from touching each other during ejection or over travel. This results in a longer lasting collapsible core that produces higher quality parts.

The DME S-Core Dovetail Cores allow for: simplified smaller molds, faster cycle times, improved part quality and reduced mold maintenance over traditional devices. It also helps reduced mold maintenance over traditional unscrewing devices. Making it a better choice for your threading or undercut application.

THE DME S-CORES CAN BE MANUFACTURED IN DIFFERENT VERSIONS.

The DME S-Cores can be manufactured in multiple versions depending on part geometry.

6 Segments

Three (3) large and three (3) small slide segments each. Provides sufficient collapse for undercuts up to 600mm.



Ready to Mold

Collapsed for Ejection

8 Segments

Four (4) large and four (4) small slide segments each. Used for intermediate (medium) undercuts.

DME S-Core's can be designed in Oval and Square shapes to compensate for part deformation/shrink.



Ready to Mold

Collapsed for Ejection

12 Segments

The smallest possible collapsible core available.

Design optimized for producing undercuts on diameters as small as 6mm.



Ready to Mold

Collapsed for Ejection

COLLAPSIBLE CORE COMPARISON

DME S-Core

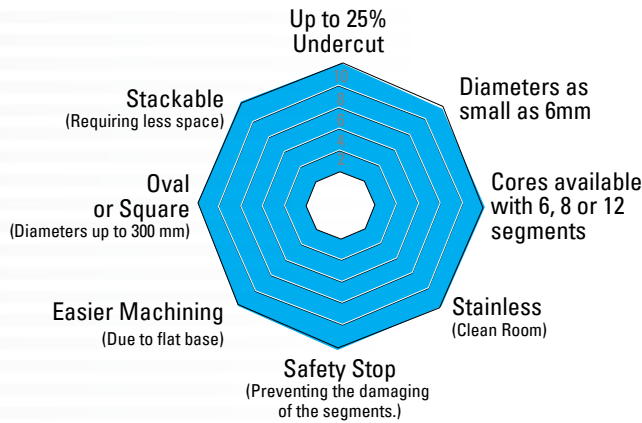

Other Collapsible Cores

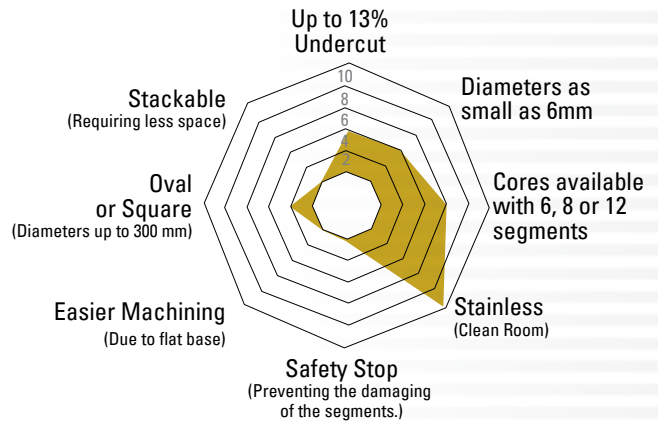

DME S-CORE

WITH PATENTED SAFETY STOP

DME S-Core Safety Stop protects the folding segments from colliding when fully opened or over traveled.

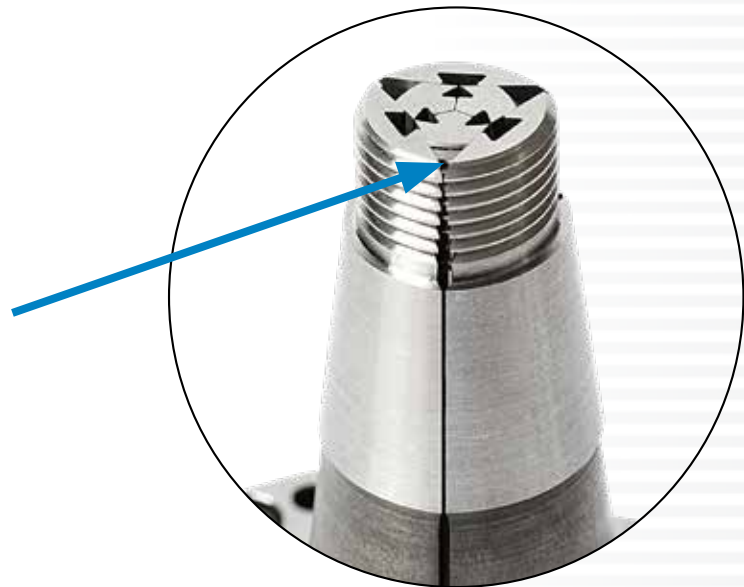

- Unlike other products on the market, the DME S-Core has safety stops built into the corners of the folding segments to prevent them from colliding with one another in the event of over travel.
- The safety stop is incorporated in all of the folding core segments in the head area (between the three retaining rings).
- Folding segments are made from 420 stainless steel and the center guide is made from H13.
- **Safety stops come standard on all DME S-Cores.**

DME S-CORE RETAINING RINGS

Want to produce more parts in a smaller space? The DME S-Core Rack System allows for cores to be placed closer together by utilizing a common retaining ring. This is an important feature when space in the mold is limited. This allows designers to create smaller molds to run on smaller presses - saving time and money. Rack systems can be made with up to 8 cores and a minimum spacing of 30mm, however this is dependent on the size of the product being produced and the required under cut depth.



DME S-CORE ADDING DETAIL MADE EASY

DME can provide the DME S-Core ready to install with the complete thread or undercut detail already machined in, however in some cases customers like to complete this detailed work. The new DME S-Core is designed with a flat bottom (shown below). When the core is positioned flat it is at location "zero" or "molding position" allowing for ease of setup to perform final machining or EDM.

NOTE: Manufacturing fixture available upon request at no additional cost when purchasing all DME S-CORES.



DME S-CORE STYLES EXAMPLES



STANDARD



CUSTOM



RECTANGLE OPENING



DLC COATED

When designing your mold base for a given product many of the choices of materials and components are based on the expected life cycle/required part count of the mold. If the mold is to be ran for years to come or you are simply trying to maximize the cycles between PM, adding DLC (Diamond-like-carbon) coating to your DME S-Core you will obtain a superior component that will last.

DLC is an amorphous carbon layer that provides a very high hardness and an extremely low friction coefficient providing the following benefits: extends the life of the core, reduces the resins ability to adhere to the core and protects the core from corrosion caused by exhaust gases.



**DME S-CORE RACK SYSTEM
(30MM SPACING)**

Up to 8 cores can be racked as close as 30mm apart depending on part size. Providing less footprint required ultimately reducing the overall mold base/press size required.

DME S-CORE NEW TECHNOLOGIES FOR A NEW WAY TO DESIGN

In the example below the core is being actuated from the side without the use of cylinders. We are demonstrating how the use of horn/angel pins are used to delay the opening of the large slide carrier. This is accomplished by slotting the horn/angle pin holes in the back end of the large carrier. The horn/angle pins do not engage in the large slide carrier to move the carrier back until after the small slide is all the way in the back position. This provides a “two stage sequence” action from the side.

Sequence:

1. When the mold opens the inside slide retracts back the DME S-Core causing the folding segments to collapse to the open position.
2. Slotted holes in large carrier are there to create a delay in movement until the small slide is in the back position.

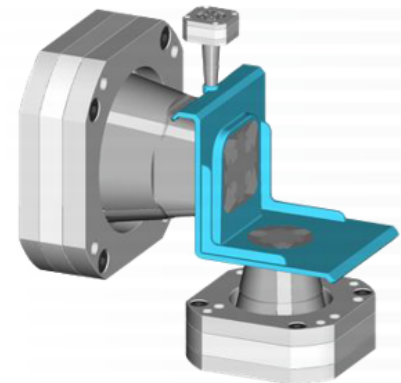

**3 DIFFERENT S-CORES
IN 1 MOLD**

DME S-Cores can be designed to be used in complex mold geometries.

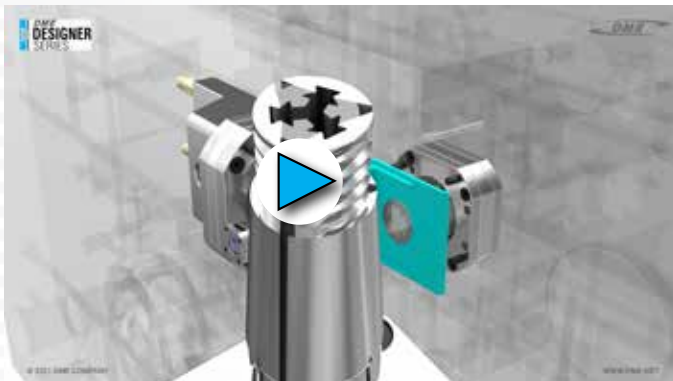

SEE IT IN ACTION: dme.net/s-core

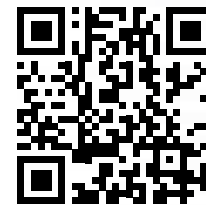

MULTIPLE S-CORES PIGGY-BACK SEQUENCING

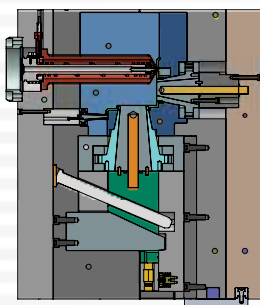

SECTION A-A
Mold Closed

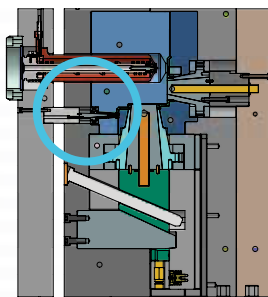

SECTION B-B
Top Clamp Plate Moves 17.5mm
Top DME S-Core Retracts

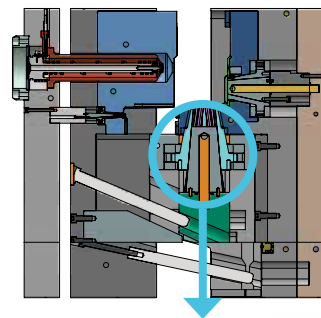

SECTION C-C
Inner DME S-Core Retracts

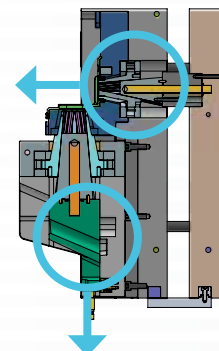

SECTION E-E
Mold Fully Opens Both Slides Retract 10mm
B-Side + Ejector Plates Move Forward
Allowing The Core Side DME S-Core To Retract

EZ-LATCH COMPLETE YOUR MOLD DESIGN WITH EZ-LATCH LOCK SYSTEM

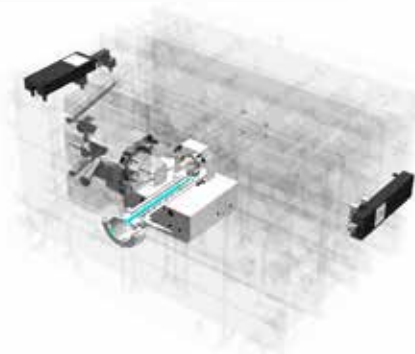

The **DME EZ-LATCH** Lock is the easy solution for all plate control application including three plate molds, two-stage ejection and early plate return.

The DME EZ-LATCH is the ideal solution to pair with the DME S-Core making your mold simple and reliable in multiple applications.

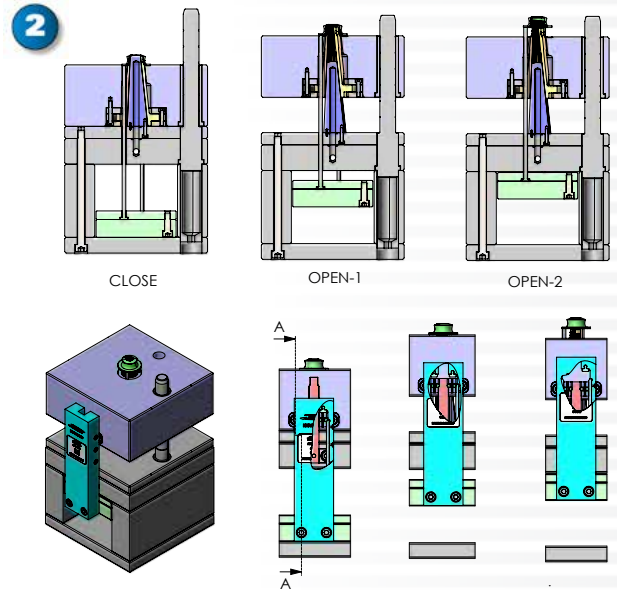
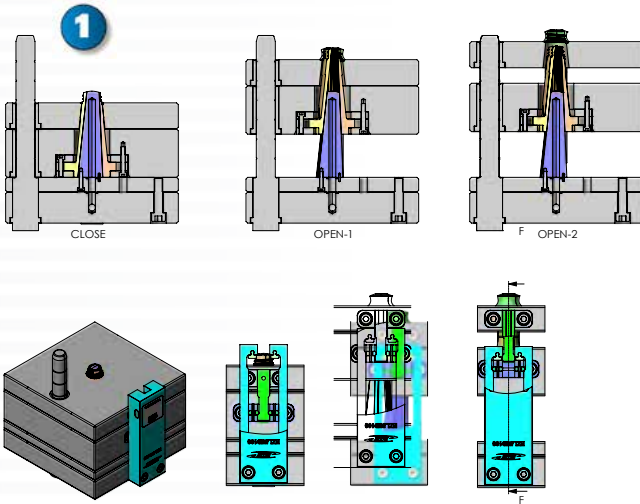

Application Example:

- 1** Example one allows for no rails/ejector box. All action is controlled by EZ-LATCH. As the mold opens, the center guide withdraws collapsing the core the stripper plate ejects the part.
- 2** Example two is a traditional stripper plate with ejection. As the mold opens the EZ-LATCH allows the B-plate and ejector plate to move simultaneously forward to open position. When the B plate reaches the stop position, which the latch locks control, the ejector plate continues forward to evacuate the part out of the mold.
- 3** Example three is also two stage ejection, the mold is opened retracting the core's center guide, EZ-LATCH keeps the stripper plate together with the "B" plate, the ejector plate is then pushed forward and actions the stripper plate.

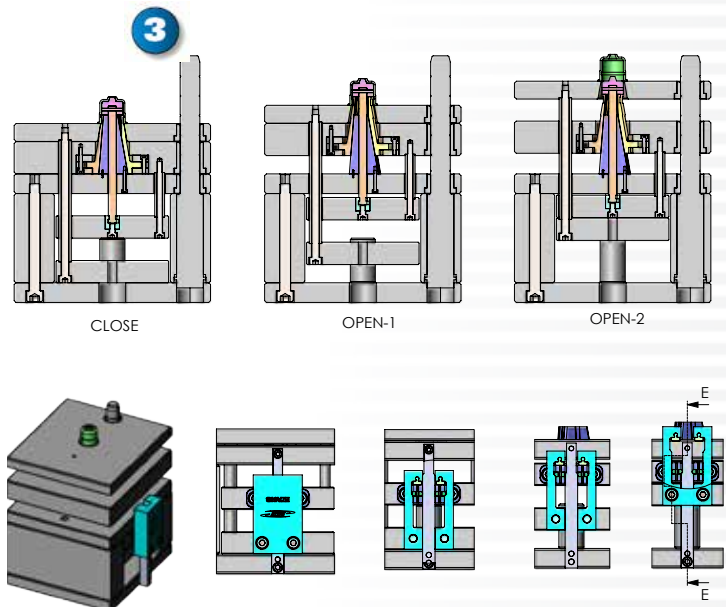

DME S-CORE INSTALLATION EXAMPLES

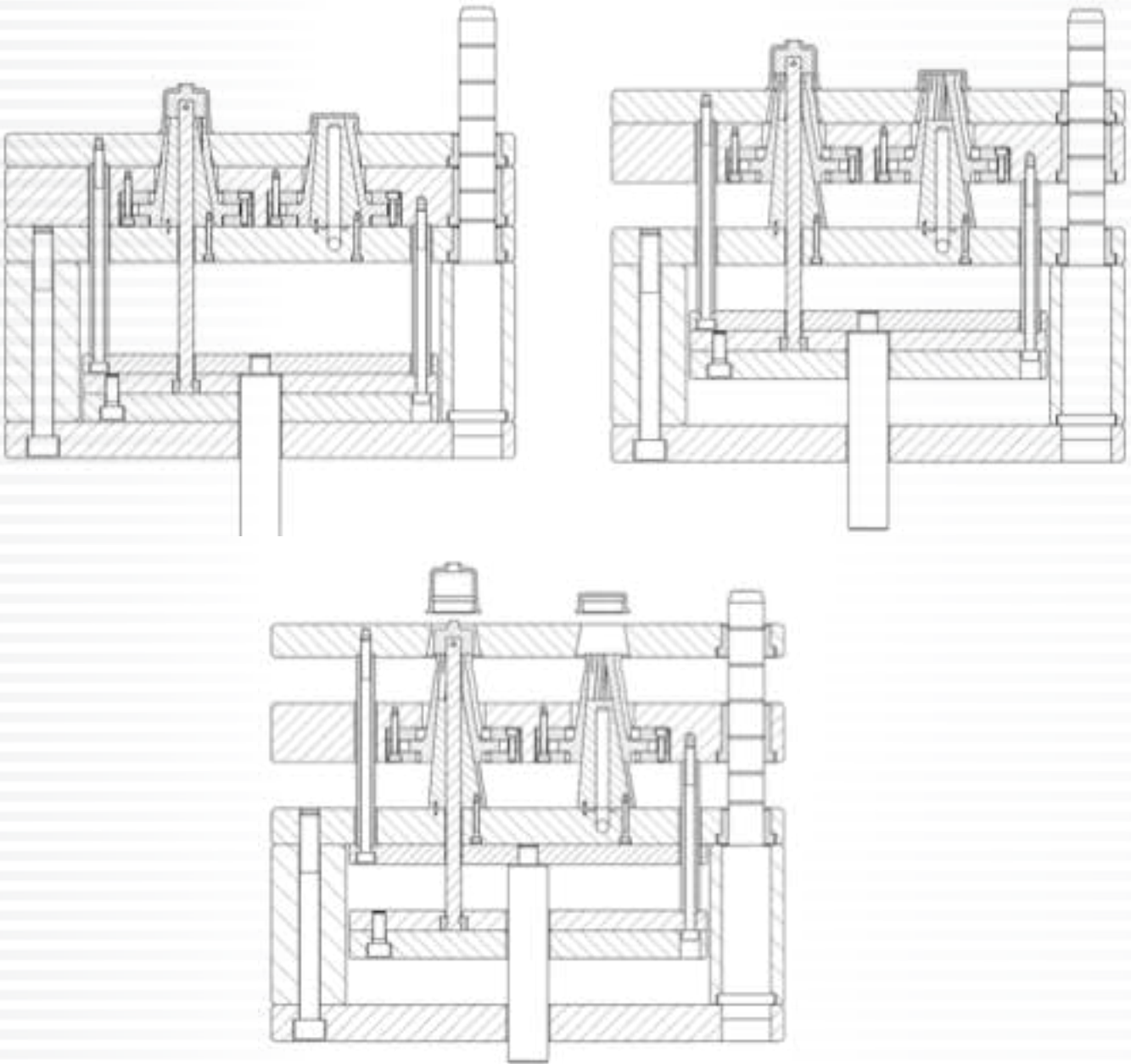

DME EZ-Latch System recommended, and designed for, proper sequencing of plates when using DME S-Cores.

DME S-CORE

ASSEMBLY (EXAMPLE 1 OF 2)

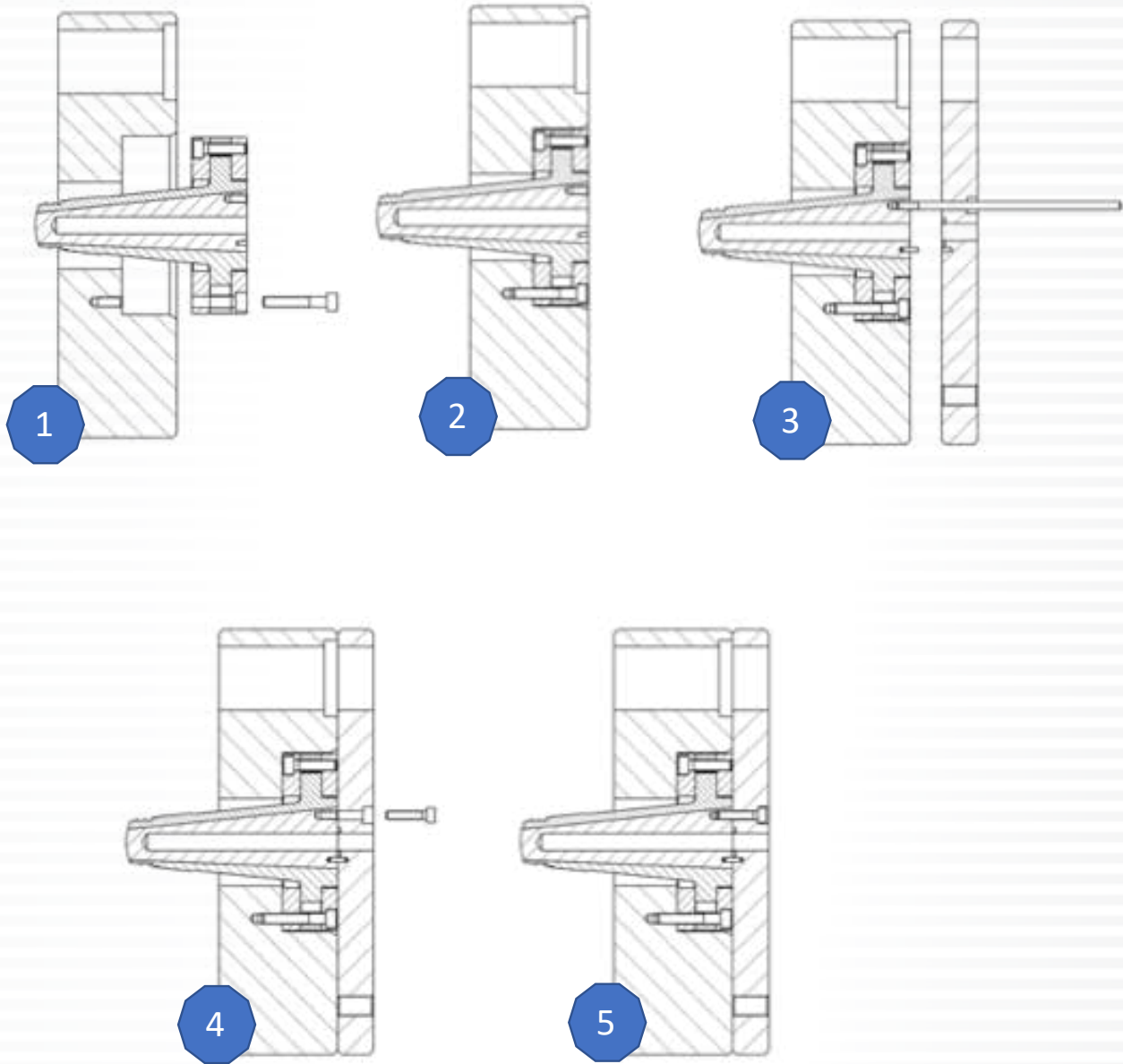

DME S-CORE

ASSEMBLY (EXAMPLE 2 OF 2)

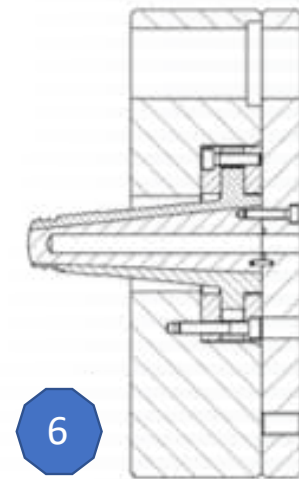
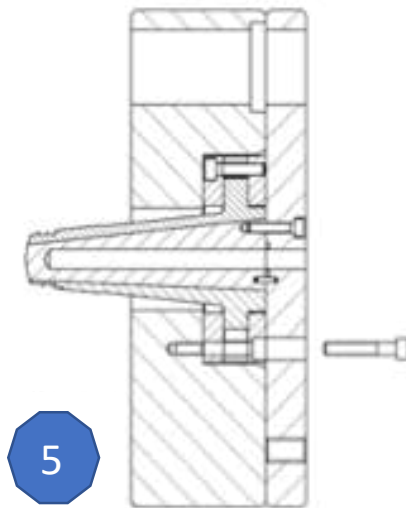
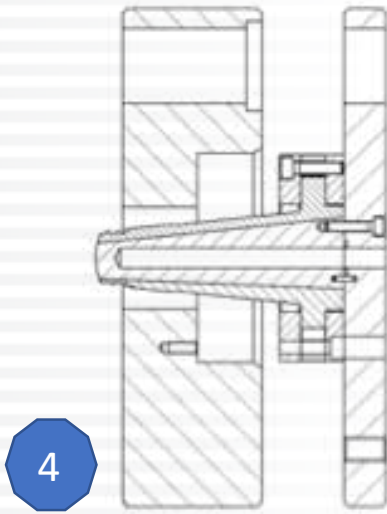
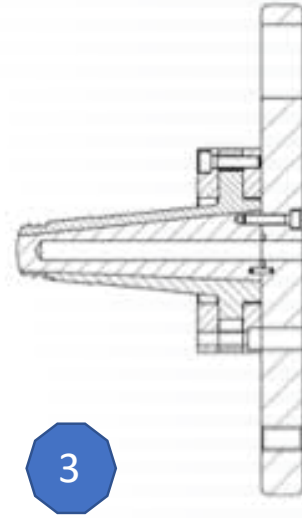
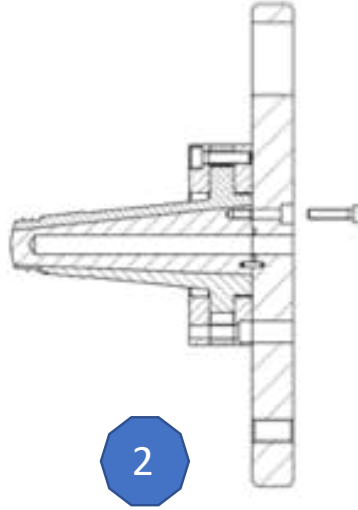
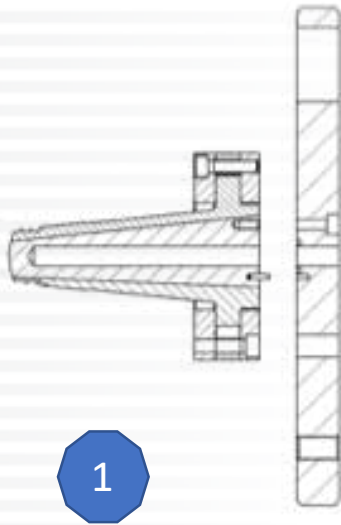

DME S-CORE

ADDITIONAL INFORMATION

- Collapsible cores have a maximum speed of 100mm / sec. during movement.
- Collapsible cores should be dismantled and cleaned as part of the PM of the mold.
- Before assembly, all guide surfaces should be greased with a high-quality grease such as DME's Krytox™ or Super Grease
- Preventive maintenance of the Collapsible cores must be carried out repeatedly during their lifetime.



WARRANTY

- Collapsible cores without a coating have a service life of approx. 500,000 cycles*.
 - Collapsible cores with DLC coating have a service life of approx. 1,000,000 cycles*.
- *Depends on the plastic material used

With tens of thousands of products to choose from, DME is your one-stop shop for everything molding. From complex undercuts solutions and plate control to standard pins, bushings and interlocks, the DME line of mold components will help you build or rebuild your mold base inside out, top to bottom. Industrial Supplies, Mold Bases, MUD Quick-Change, Control Systems, and Hot Runner solutions round out our extensive offering to truly be your one-stop shop.



World Headquarters

DME Company LLC

29111 Stephenson Highway
Madison Heights, MI 48071

800-626-6653 toll-free tel

248-398-6000 tel

888-808-4363 toll-free fax

www.dme.net web

dme@dme.net e-mail

DME of Canada Ltd.

A-99 Gulf Blvd.
Brampton, Ontario
Canada L4V 1J6

800-387-6600 toll-free tel

905-677-6370 tel

800-461-9965 toll-free fax

dme_canada@dme.net e-mail

DME Mexico / South America

Circuito el Marques Notre, No.55
Parque Industrial El Marqués
El Marqués, Querétaro, CP 76246

52.442.713.5666 tel

dme_mexico@dme.net

