

# P.E.T.S.® Valve Gate Hot Runner Solutions From DME

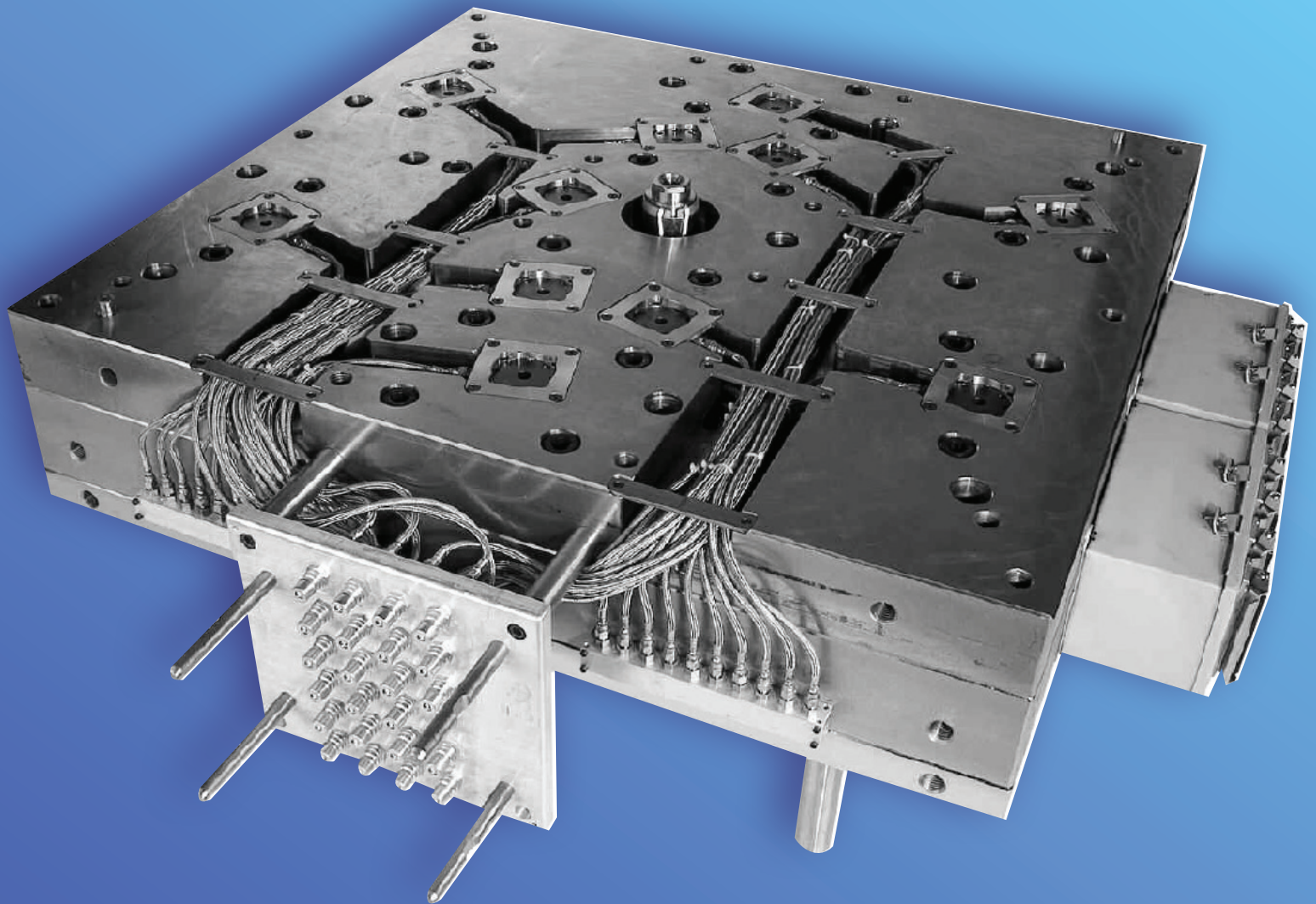

**Valve gate system solutions  
for every market**



# DME P.E.T.S. Valve Gate Hot Runner Solutions

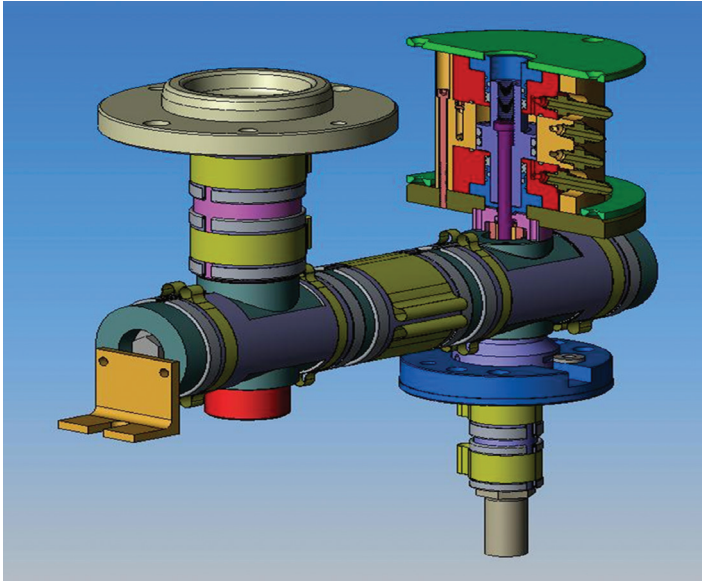

## System Features:

- Low shear melt channels for improved processing and part quality
- Hydraulic, pneumatic or electric pin actuation options
- Round or rectangular manifold construction
- Full "hot half" system or unitized options
- Short cycle times
- No material waste
- Inch and metric nozzle tips available
- Bodies and tips designed to fit your molding application
- Standard, replaceable components

## Benefits:

- Dual-seal P-20 radius plug
- Improves engineering precision
- Round or rectangular manifold construction
- Heavy gauge cover plates
- Multiple zoning
- Internal water-cooled cylinders
- Pre-wired

## Results:

- Eliminates "dead spots" that can trap and degrade material
- Achieves precise drop placement
- Retains reliability
- Solution meets your application needs
- Improves heat transfer
- Increases heat control
- Better part quality
- Reduces cycle time

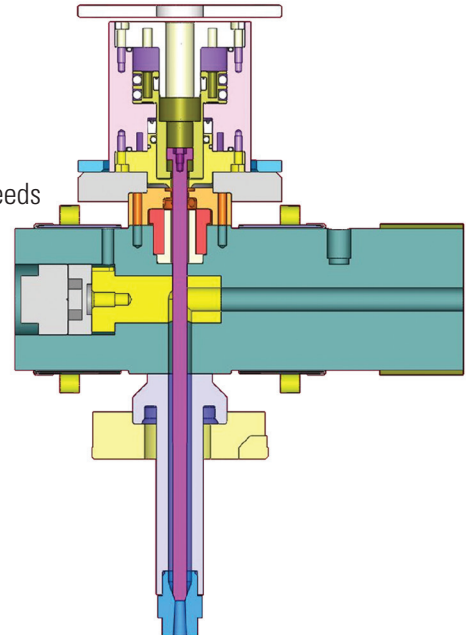

For Valve Gate Hot Runner System quote inquiries, please call DME and ask to speak to a Hot Runner Representative, or email us at [appl\\_eng@dme.net](mailto:appl_eng@dme.net). For technical inquiries, please email us at [hrstech@dme.net](mailto:hrstech@dme.net).



## World Headquarters

### DME Company LLC

29111 Stephenson Highway  
Madison Heights, MI 48071

800-626-6653 toll-free tel

248-398-6000 tel

888-808-4363 toll-free fax

[www.dme.net](http://www.dme.net) web

[sales@dme.net](mailto:sales@dme.net) e-mail

## DME of Canada Ltd.

6210 Northwest Drive  
Mississauga, Ontario  
Canada L4V 1J6

800-387-6600 toll-free tel

905-677-6370 tel

800-461-9965 toll-free fax

[dme\\_canada@dme.net](mailto:dme_canada@dme.net) e-mail

## DME Europe

DME Belgium C.V.B.A.  
Industriepark Noord  
B-2800 Mechelen  
Belgium

32-15-215011 tel

32-15-218235 fax

[sales@dmeeu.com](mailto:sales@dmeeu.com) e-mail