

D-M-E

CLOSED LOOP TEMPERATURE CONTROL SYSTEMS (G-Series)

SAIB

Technical Data Sheet TCMA-1

**ANALOG SETPOINT
TEMPERATURE MODULES**
FC10AG: 10 AMPS, 2400 WATTS
FC15AG: 15 AMPS, 3600 WATTS

ANALOG SETPOINT TEMPERATURE CONTROL MODULES

D-M-E high performance temperature control modules are fully time proportioning closed loop feedback units capable of precise control over a wide range of operating conditions. They incorporate all of the superior temperature control and safety features that have been developed and proven by D-M-E through past practical experience.

Fully solid state, employing the latest state of the art integrated circuit technology and using no mechanical relays, these modules are completely self-contained units which can hold temperature to $\pm 5^\circ\text{F}/3^\circ\text{C}$ in a properly designed system. Zero crossover AC power switching, selection of automatic or manual control and automatic power shutdown in the event of thermocouple break are a few of the standard features.

Ease of operation with a minimum of operator controls, as well as greater control accuracy, reliability and safety are hallmarks of the new D-M-E G-Series temperature control modules.

FEATURES:

- Advanced circuitry for reliable and precise temperature control
- Zero crossing triac triggering for minimum RFI
- Automatic thermocouple break power shutdown
- Automatic or Manual control mode
- Automatic thermocouple cold junction compensation
- Plug in design for module interchangeability
- 100% solid state circuitry, no mechanical relays
- Complete self contained, no external power supplies, triac switches etc. required
- Fully fused and grounded
- Electrically isolated with grounded front panel for operator safety
- Simple operation
- Compatible with all G-Series Main Frames

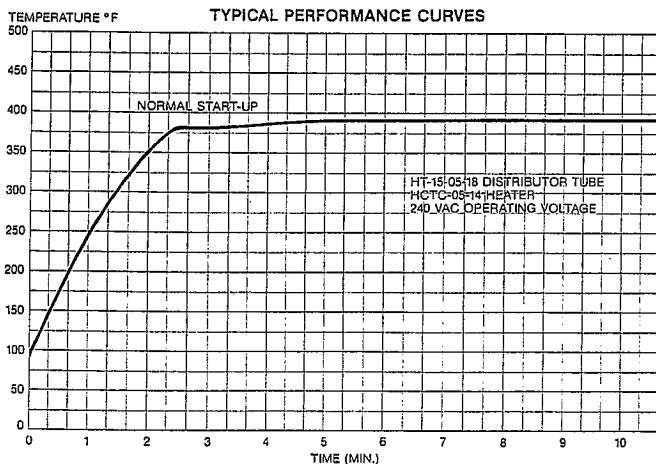
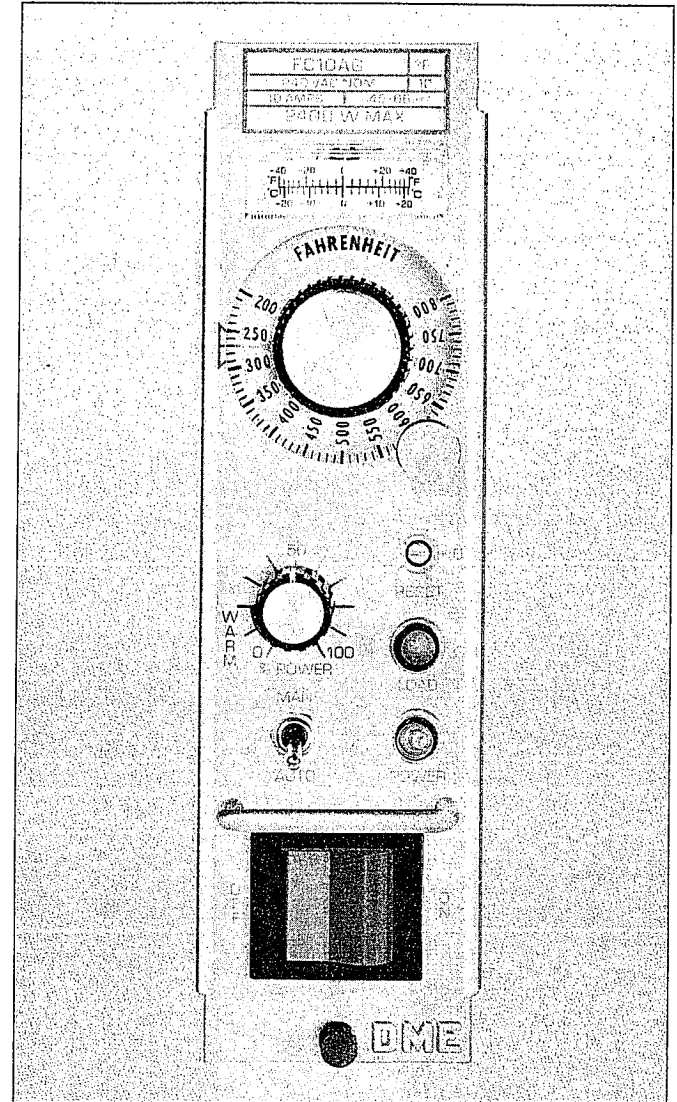

ADDITIONAL FEATURES:

- Thermocouples may be grounded or ungrounded
- Deviation meter operational in Manual mode as long as thermocouple is intact
- High impedance potentiometric input allows long thermocouple wiring
- Fast cycle time for rapid temperature correction
- Analog setpoint dial equipped with dial lock
- Power supplies and circuitry fully temperature compensated
- Pilot lights to define module functions
- 240/120 Volt operation, 240 Volts is standard
- Oversize heat sink for cool, reliable operation
- Transient and dv/dt suppression included
- Type "J" thermocouple is standard
- Calibrated "0" center deviation meter
- Fahrenheit or Celsius module available

TECHNICAL SPECIFICATIONS LISTED ON REVERSE SIDE

PERFORMANCE SPECIFICATIONS:

Control Mode, Auto. and Manual Variable time proportioning
 Temperature Range °F/°C Calibrated 200 to 800°F/100 to 425°C
 Control Accuracy ±.5°F/.3°C dependent on the total thermal system
 Temperature Stability ±1.5% of full scale over the ambient range of 32 to 140°F/0°C to 60°C
 Calibration Accuracy Better than 0.5% of full scale
 Proportional Bandwidth Fixed at ±20°F/11°C
 Cycle Time Fixed at 0.3 second

INPUT SPECIFICATIONS:

Thermocouple Sensor Type "J", grounded or floating
 External Thermocouple Resistance Up to 1000 Ohms
 Thermocouple Isolation Isolated from ground and supply voltages
 Cold Junction Compensation Automatic, better than 0.02°F/°F, 0.01°C/°C
 Thermocouple Break Protection Upscale, automatically removes power
 Input Type Potentiometric
 Input Impedance 22 Megohms
 Input Protection Diode clamp, RC filter
 Input Amplifier Stability Better than 0.02°F/°F, 0.01°C/°C
 Input Dynamic Range Greater than 1000°F/550°C
 Common Mode Rejection Ratio Greater than 100 dB
 Power Supply Rejection Ratio Greater than 90 dB

OUTPUT SPECIFICATIONS:

Voltage 240 VAC nominal, single phase, 120 VAC available
 Power Capability 10 amperes, 2400 watts @ 240 VAC, 1200 watts @ 120 VAC
 15 amperes, 3600 watts @ 240 VAC, 1800 watts @ 120 VAC
 Power Switch Internal solid state triac, triggered by zero AC crossing pulses
 Overload Protection Triac and load use high speed fuses. Both sides of AC line are fused
 Transient Protection dv/dt and transient pulse suppression included
 Power Line Isolation Optical coupler and transformer isolation

CONTROLS AND INDICATORS:

Setpoint Control Precision single turn potentiometer with calibrated dial and dial lock
 Range 200 to 800°F/100 to 499°C
 Resolution 2°F/1.1°C
 Accuracy Better than 5°F/3°C
 Manual Power Control Single turn potentiometer, calibrated scale
 Range 0 to 100%
 Linearity 10%
 Reset Adjustment Recessed trimpot
 Range ±40°F/22°C
 Power ON-OFF Rocker switch, UL, CSA, VDE approved
 Automatic/Manual Miniature toggle switch
 Temperature Deviation Meter Analog, D'Arsonval jeweled movement
 Range ±40°F/22°C
 Power "ON" Indicator Amber neon light
 Power to Load Indicator Red neon light

ELECTRICAL POWER SPECIFICATIONS:

Input Voltage 240/120 VAC, ±20%
 Frequency 48 to 62 Hz
 DC Power Supplies Internally generated, regulated and temperature compensated
 Module Power Usage Less than 1 watt
 Dimensions 2"W x 7"H x 7½"D
 5.08 x 17.78 x 19.05 cm

ORDERING INFORMATION:

CATALOG NUMBERS RATING
 For 240 VAC (Standard)
 FC10AG 10 amperes, 2400 watts
 FC15AG 15 amperes, 3600 watts
 For 120 VAC (Special Order)
 FC10AG1 10 amperes, 1200 watts
 FC15AG1 15 amperes, 1800 watts

CELSIUS, ADD X AFTER FC IN CATALOG NUMBER.

FUSE REQUIREMENTS

For 10 ampere module (1) ABC-10 and (1) 13X-10 fuse
 For 15 ampere module (1) ABC-15 and (1) 13X-15 fuse

MODULE/FRAME USE CHART:

MODEL FC10AG/FC15AG (G-Series Only)

	G-Series Main Frame				
	MF2	MFF2	MF	MFN	MFC
Full Operation	✓	✓	✓		✓
Manual Only				✓	
Compatible with Accessory Modules					

Note: G-Series modules will fit into all G-Series frames. The above chart indicates what module operations can be utilized in any particular frame.

FOR ADDITIONAL INFORMATION, CALL YOUR NEAREST D-M-E SERVICE CENTER



D-M-E COMPANY

A Fairchild Industries Company

D-M-E SERVICE CENTERS UNITED STATES and CANADA

2376 John Glenn Drive, N.E.
ATLANTA, GA 30341
(404) 451-2674

558 Leo Street
DAYTON, OH 45404
(513) 461-3980

83 Keystone Dr.
LEOMINSTER, MA 01453
(617) 537-4716

6116 Wayzata Blvd.
MINNEAPOLIS, MN 55416
(612) 546-5581

11839 Westline Industrial Dr.
ST. LOUIS, MO 63141
(314) 432-2233

502 Brookpark Road
CLEVELAND, OH 44109
(216) 741-9202

1551 N. W. 69th Street
FORT LAUDERDALE, FL 33309
(305) 974-4220

29111 Stephenson Highway
MADISON HEIGHTS (WORLD HEADQUARTERS)
(DETROIT), MI 48071
(313) 398-6000

6210 Northwest Drive
MISSISSAUGA (TORONTO), ON L4V 1J6
(416) 677-6370

4263 Clyde Park
WYOMING (GRAND RAPIDS), MI 49509
(616) 531-9790

2143 Joe Field Road,
Suite 200
DALLAS, TX 75229
(214) 620-1400

1217 Central Avenue
HILLSIDE (NEWARK), NJ 07205
(201) 355-3500

1975 N. 17th Avenue
MELROSE PARK (CHICAGO), IL 60160
(312) 626-2900

1101 Monterey Pass Road
MONTEREY PARK (LOS ANGELES), CA 91754
(213) 263-9261

* D-M-E MINI BRANCHES

D-M-E

OPEN LOOP POWER CONTROL SYSTEMS (G-Series)

7/11/76
Technical Data Sheet PCM-1**POWER CONTROL MODULES
WITH REGULATED OUTPUT**
PMR10G: 10 AMPS, 2400 WATTS
PMR15G: 15 AMPS, 3600 WATTS

POWER CONTROL MODULES WITH REGULATED OUTPUT

These D-M-E power control modules have been designed for use with systems that do not require closed loop control. Incorporated are all the superior control and safety features that have been developed and proven by D-M-E through past practical experience.

They are simple to use, require no thermocouple and, due to the special electronic circuits involved, provide constant power to the load, even with wide power line variations.

Fully solid state, employing the latest state of the art integrated circuit technology and using no mechanical relays, these modules are completely self-contained units which provide excellent power regulation. Zero AC power switching, time proportioning operation, including a standby/warmup heat function are a few of the standard features.

FEATURES:

- Automatic power compensation for AC line voltage variations
- Maintains constant heater power
- Open loop operation requires no thermocouple
- Standby heat mode for constant low output power
- 100% output power mode if required, instant return to setpoint
- Linear percent power control
- Calibrated percent power meter for 208, 220, 240 VAC
- Completely self contained, no external power supplies, triac switches etc. required
- Plug in design for module interchangeability
- Fully fused and grounded
- Electrically isolated with grounded front panel for operator safety
- Simple operation
- Compatible with all G-Series Main Frames

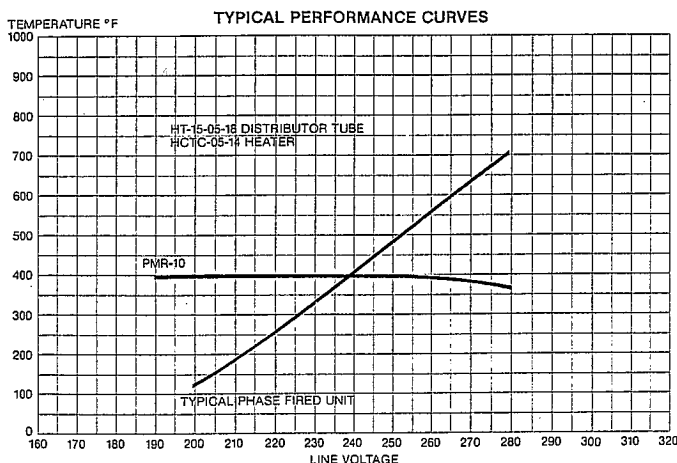
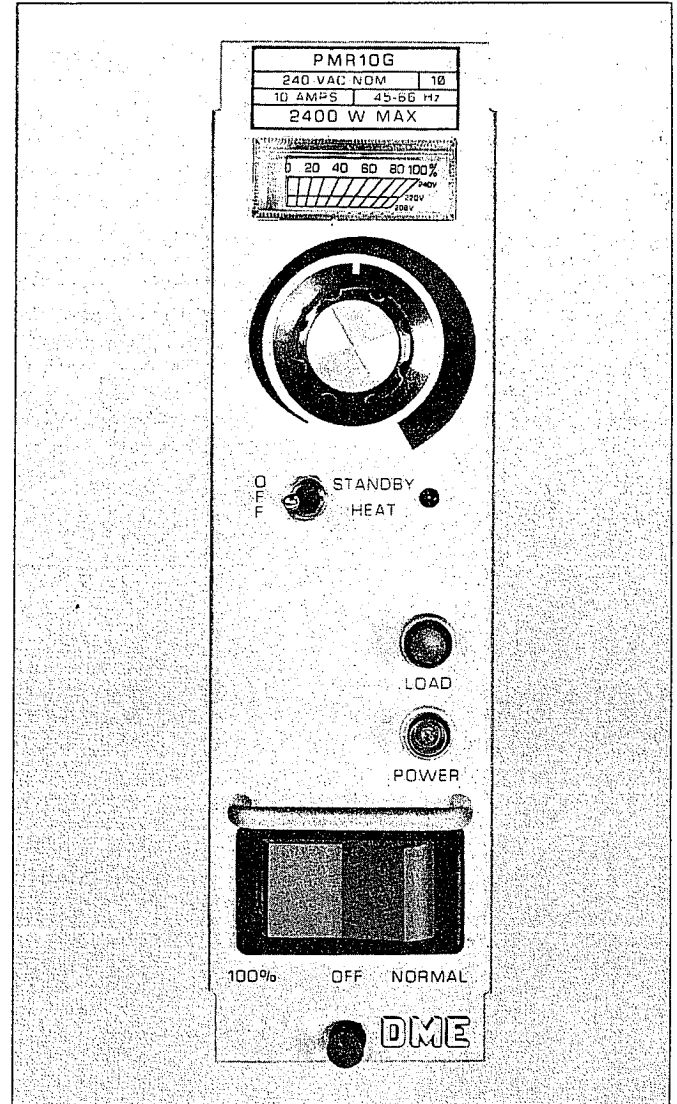

ADDITIONAL FEATURES:

- 100% solid state circuitry, no mechanical relays
- Power supplies and circuitry fully temperature compensated
- Pilot lights to define module functions
- 240/120 volt operation, 240 volts is standard
- Oversize heat sink for cool, reliable operation
- Transient and dv/dt suppression included
- Zero crossing triac triggering for minimum RFI
- D'Arsonval type meter with jeweled bearings
- Both sides of the AC line are high speed fused

TECHNICAL SPECIFICATIONS LISTED ON REVERSE SIDE

PERFORMANCE SPECIFICATIONS:

Power Regulation	±3% of the set output power for line voltage variation of 190 to 280 VAC (±20% of 240 VAC)
Power Setpoint Resolution	5% of maximum power
Control Mode	Variable time proportioning
Cycle Time	Fixed at .3 second
Temperature Stability	±1.5% of full scale over the ambient range of 32 to 140° F/0 to 60°C
Calibration Accuracy	Better than 5% of full scale
Standby Heat Output Power	10-15% of maximum power

OUTPUT SPECIFICATIONS:

Voltage	240 VAC nominal, single phase. 120 VAC available
Power Capability	10 amperes, 2400 watts @ 240 VAC, 1200 watts @ 120 VAC 15 amperes, 3600 watts @ 240 VAC, 1800 watts @ 120 VAC
Power Control Range	0 to 100% of maximum output power
Power Switch	Internal solid state triac, triggered by zero AC crossing pulses
Overload Protection	Triac and load use high speed fuses. Both sides of AC line are fused
Transient Protection	dv/dt and transient pulse suppression included

CONTROLS AND INDICATORS:

Percentage Power Control	Linear single turn potentiometer Range 0-100% Linearity 10%
Power ON-OFF	Three position rocker switch. 100%-OFF-ON
Normal/Standby Heat	Miniature toggle switch
Percent Power Meter	Analog, D'Arsonval jeweled movement Calibrated 0-100% for 208, 220, 240 VAC
Power "ON" Indicator	Amber neon light
Power to Load Indicator	Red neon light
Standby Heat Indicator	Red LED

ELECTRICAL POWER SPECIFICATIONS:

Input Voltage	240 VAC ±20% 120 VAC available
Frequency	48 to 62 Hz
DC Power Supplies	Internally generated, regulated and temperature compensated
Module Power Usage	Less than 5 watts
Dimensions	2"W x 7"H x 7½"D 5.08 x 17.78 x 19.05 cm

ORDERING INFORMATION:

CATALOG NUMBERS	RATING
<i>For 240 VAC (Standard)</i>	
PMR10G	10 amperes, 2400 watts
PMR15G	15 amperes, 3600 watts
<i>For 120 VAC (Special Order)</i>	
PMR10G1	10 amperes, 1200 watts
PMR15G1	15 amperes, 1800 watts
FUSE REQUIREMENTS	
<i>For 10 ampere module</i>	(1) ABC-10 and (1) 13X-10 fuse
<i>For 15 ampere module</i>	(1) ABC-15 and (1) 13X-15 fuse

MODULE/FRAME USE CHART:

MODEL PMR10G/PMR15G (G-Series Only)

	G-Series Main Frame				
	MF 2	MFF 2	MF	MFN	MFC
Full Operation	✓	✓	✓	✓	✓
Manual Only					
Compatible with Accessory Modules					

Note: G-Series modules will fit into all G-Series frames. The above chart indicates what module operations can be utilized in any particular frame.

FOR ADDITIONAL INFORMATION, CALL YOUR NEAREST D-M-E SERVICE CENTER



D-M-E SERVICE CENTERS UNITED STATES and CANADA

2376 John Glenn Drive, N.E.
ATLANTA, GA 30341
(404) 451-2674

558 Leo Street
DAYTON, OH 45404
(513) 461-3980

83 Keystone Dr.
LEOMINSTER, MA 01453
(617) 537-4716

6116 Wayzata Blvd.
MINNEAPOLIS, MN 55416
(612) 546-5581

11839 Westline Industrial Dr.
ST. LOUIS, MO 63141
(314) 432-2233

502 Brookpark Road
CLEVELAND, OH 44109
(216) 741-9202

1551 N. W. 69th Street
FORT LAUDERDALE, FL 33309
(305) 974-4220

29111 Stephenson Highway
MADISON HEIGHTS (WORLD HEADQUARTERS)
(DETROIT), MI 48071
(313) 398-6000

6210 Northwest Drive
MISSISSAUGA (TORONTO), ON L4V 1J6
(416) 677-6370

4263 Clyde Park
WYOMING (GRAND RAPIDS), MI 49509
(616) 531-9790

2143 Joe Field Road,
Suite 200
DALLAS, TX 75229
(214) 620-1400

1217 Central Avenue
HILLSIDE (NEWARK), NJ 07205
(201) 355-3500

1975 N. 17th Avenue
MELROSE PARK (CHICAGO), IL 60160
(312) 626-2900

1101 Monterey Pass Road
MONTEREY PARK (LOS ANGELES), CA 91754
(213) 263-9261

* D-M-E MINI BRANCHES

TECHNICAL SERVICE MANUAL

FC-10G/FC-15G SERIES

TEMPERATURE CONTROLLERS

D-M-E Company
29111 Stephenson Highway
Madison Heights, Michigan 48071

GENERAL DESCRIPTION

The FC10G/FC15G series is a family of modular closed-loop temperature controllers designed for plug-in installation in a group of standard main frames. These controllers are available with either 10 or 15 ampere capability and with a variety of optional operating features. These controllers are supplied calibrated in degrees Fahrenheit unless an "X" appears in the model number which denotes degrees Celsius calibration (e.g. FCX10AG).

The basic models that are available are:

FC10AG/FC15AG	Analog setpoint controller
FC10ASG/FC15ASG	Analog setpoint controller with SloStart option
FC10DG/FC15DG	Digital setpoint controller
FC10DSG/FC15DSG	Digital setpoint controller with SloStart option

ELECTRICAL SPECIFICATIONS

INPUT: 120/240 VAC $\pm 20\%$, 48 to 62 Hz (240 VAC normal)

OUTPUT: FC10G-10 amperes, 2400 watts, single phase
FC15G-15 amperes, 3600 watts, single phase

TEMPERATURE RANGE: 200° to 800°F (Fahrenheit units)
100° to 400°C (Celsius units)

TEMPERATURE SENSOR: Type J thermocouple

TEMPERATURE SET CONTROL: Analog units - Single turn potentiometer with calibrated dial
Digital units - 3-digit thumbwheel switch

RESOLUTION: Analog units ± 2 degrees Fahrenheit
Digital units ± 1 degree Fahrenheit

ACCURACY: Better than 0.5 degrees Fahrenheit

MANUAL POWER CONTROL: Single turn with calibrated scale

MANUAL POWER RANGE: 0 to 100%

TEMPERATURE DEVIATION METER: Analog zero center type $\pm 40^\circ\text{F}$ and $\pm 20^\circ\text{C}$ scale

SloStart DURATION: 5.3 minutes $\pm 5\%$

SloStart MODE OUTPUT POWER: 50% of maximum power

CONTROL MODE: Time proportioning

OVERLOAD PROTECTION: Fused on both sides of AC line. Load and triac protected by high speed fuse.

INSTALLATION

The model FC10G/FC15G Series Temperature Controller is ready to use as shipped from the factory. No special unpacking procedures are required prior to installation into a main frame.

CAUTION: Never insert or remove a controller from a main frame with the AC power on. Disconnect AC power before servicing system to avoid damaging the controller and main frame.

HAZARDOUS POTENTIALS EXIST ON COMPONENTS INSIDE OF CONTROLLER. NEVER SERVICE EQUIPMENT WITH POWER APPLIED.

To install a controller into a main frame, release the locking device on the lower edge of the module's front panel by gently pulling the plunger away from the panel. Align the upper and lower edges of the printed circuit board on the controller with their respective card guides on the main frame and slide the unit all the way into the frame until the rear connector is completely engaged. Lock the controller into the frame by depressing the plunger on the locking device.

120V/240V OPERATION

Unless otherwise specified, temperature controllers are shipped from the factory wired for 240 VAC operation. To convert for 120 VAC operation, it is necessary to cut a copper land on the printed circuit board and insert two jumper wires. Refer to the schematic diagram for the location of these connections.

OPERATION

The following items refer to front panel controls and indicators on the FC10G/FC15G Temperature Controller. The purpose of this section is to familiarize you with the function of each of the indicators and adjustments provided.

1. MODULE ON-OFF SWITCH
Applies AC power to the module. This switch must be in the OFF position when removing or inserting module.
2. A.C. POWER ON LAMP
Amber neon lamp indicates that power is applied to the controller when the power switch is ON and the fuses are good.
3. TEMPERATURE SETPOINT DIAL
Analog or digital, is used to adjust the desired setpoint or operating temperature of the controller.

4. TEMPERATURE OFFSET METER
Zero center scale meter indicates the temperature differential between the thermocouple and the temperature setpoint dial.
5. POWER TO LOAD LAMP
Red neon lamp lights to indicate when the controller is supplying power to the load.
6. RESET ADJUSTMENT
Will move the proportional band so that the temperature deviation is reduced to zero. Adjust if necessary ONLY AFTER system has stabilized.
7. MANUAL/AUTOMATIC SWITCH
In "AUTO" position the module operates in closed-loop mode with thermocouple control.

"MAN" position allows operation of % power control, night or weekend heat. To return to automatic operation, restore switch to "AUTO" position.
8. % POWER CONTROL
This control is used for manually adjusting the power level when AUTO/MAN switch is in the MAN position. The WARM section of the calibrated dial is used for nighttime or weekend low power setting. MAN/AUTO switch must be in the MAN position.
9. SloStart SWITCH (optional)
Turns SloStart operation ON. The module will automatically switch to normal operation after SloStart period is complete. The SloStart cycle time is fixed at approximately five minutes. If the SloStart feature is not desired, turn switch to the OFF position.
10. SloStart LAMP (optional)
This lamp will blink to indicate that the module is in the SloStart mode of operation. The lamp will extinguish when the SloStart period is over.

THEORY OF OPERATION

A type J thermocouple is used to sense the temperature of the heater. Referring to the block diagram, the thermocouple voltage is applied to the input of U3, a precision operational amplifier. The output of U3 is a signal 101 times that of the thermocouple. Provisions added at the input of U3 generate a high temperature output when the thermocouple is broken.

CR4, U2D, and the associated circuitry generate a voltage to cancel or compensate for the voltage developed by the thermocouple cold junction at the input of U3. The amplified thermocouple signal and the cold junction compensating voltages are added and then compared with the set temperature, specified by R29 and U2C. The output of U2C is called the temperature error or deviation. An analog meter is provided for monitoring that temperature deviation continuously.

The temperature error is also applied to U2B where offset and manual control signals are introduced. Offset voltage is set by R36 and manual control signal is set by R35.

Q1, Q2 and the associated circuitry generate a linear sawtooth signal. U2A compares the sawtooth voltage level with the U2B output voltage level. If the sawtooth voltage is higher than the output of U2B, then the comparator output is low; otherwise it is high. A high comparator output indirectly turns on AC power to the heater load, while a low comparator output turns off AC power to the load.

A series of 120 Hz pulses is generated by the circuit of U1A and U1B. Each pulse generated coincides with the zero crossing of the AC line. This feature is essential for minimizing RFI generated when a triac is turned on. The 120 Hz pulses are gated by the signal at the output of U2A. If the output of U2A is high, the Triac Enable Circuit passes the 120 Hz pulses to the Triac Trigger Circuit, otherwise the 120 Hz pulses are blocked.

The Triac Trigger Circuit is an optically coupled thyristor. Such a device offers an exceptionally high isolation, more than 2500 volts between the AC mains and the control circuit ground. When the Triac Trigger output is activated, triac Q4 is turned on, connecting the heater load across the mains. Q4 turns itself off automatically at each zero-volt crossing of the mains.

The SloStart Circuit is an optional feature of the controller. If included the SloStart logic reduces the initial rate of temperature rise. Furthermore, the temperature will be held below 175°F during the SloStart active period.

When the controller AC power is first turned on and the SloStart function is selected, the Clock Oscillator Circuit starts generating a stable 26 Hz square wave. The SloStart logic also forces the controller to deliver 50% power to the heater load. When the 8192th square wave is received by U7, in approximately 5 minutes, the SloStart function terminates.

During the active SloStart period, the Temperature Limit Circuit, U10B, monitors the thermocouple temperature continuously. Should the temperature rise above 175°F, the SloStart Enable Circuit inhibits the heater power to prevent further temperature rise. The Temperature Limit Circuit also includes an override feature. This feature inhibits the SloStart function when the temperature is above 250°F prior to turning the power on.

MAINTENANCE

The appendix of this manual includes an electrical parts list, a schematic diagram and a parts location diagram to facilitate the servicing of the temperature control module.

All electrical and electronic parts are listed in the sequence of their circuit designation numbers as shown on the schematic diagram.

We recommend that all parts be ordered directly from the factory. The commercial equivalents of many parts have wide parameter tolerances and may not be suitable for direct replacement purposes. This is especially true with semiconductor devices, since manufacturers are continually modifying their products. Substituting "equivalent" devices may affect the performance of the temperature controller; since they may have different gains, operating voltage levels or frequency response. We can assure compliance with the original specifications if replacement parts are ordered directly from the factory.

When ordering replacement parts, please identify the temperature controller as thoroughly as possible giving the model number and serial number if available.

The replacement parts you receive may not have the same part number as that shown on the electrical parts list. This can be due to several factors:

- (A) The original vendor has discontinued manufacture of the item or can no longer manufacture it to the original specifications.
- (B) A better device for use in a particular circuit has been substituted.
- (C) Tighter controls for interchangeability have provided greater assurance of reliability with the replacement part.

CALIBRATION

All temperature controllers are factory calibrated and the adjustment trim pots sealed prior to shipment. Recalibration is not normally required unless critical components which may affect calibration accuracy are replaced.

Field calibration of temperature controllers is not recommended, since it requires the use of precision laboratory type test equipment. We suggest that controllers be returned to the factory for recalibration.

The following procedure should only be performed by qualified technical service personnel, since instrumentation accuracy and ambient temperature will affect the results.

- Equipment Required:
- 1) 4½ Digit Digital Voltmeter
 - 2) Accurate Adjustable Millivolt Source
 - 3) Digital Counter/Timer
 - 4) Card Extender or Extension Cable
 - 5) Thermometer
 - 6) Type "G" Main Frame and Load

PRELIMINARY

Connect temperature controller to main frame by means of a card extender or extension cable to allow access to internal controls with the power ON.

Connect a load to the zone under test on the main frame. Turn AC power switch ON.

A/D CONVERTER CALIBRATION (Digital Units Only)

1. Connect Digital Voltmeter so that the NEGATIVE lead goes to ground and the POSITIVE lead goes to pin 10 of U12.
2. Set thumbwheel setpoint switch to "000".
3. Adjust RG1 until DVM indicates zero.
4. Disconnect DVM from U12.

TEMPERATURE CALIBRATION

1. Place setpoint control at 200°F or 100°C. Set reset control on front panel fully clockwise to prevent cycling.
2. Connect millivolt source to thermocouple input of controller under test. Monitor the output of the millivolt source with DVM.
3. Adjust millivolt source to 3.83mv at ambient temperature of 70°F for 200°F calibration point. (For 100°C calibration point, adjust millivolt source to 4.19mv at 70°F ambient temperature.) Refer to calibration chart for millivolt settings at other ambient temperatures.
4. Adjust R21 until deviation meter on front panel indicates zero.
5. Place setpoint control to 800°F or 425°C.
6. Adjust millivolt source to 22.24mv at an ambient temperature of 70°F for 800°F calibration point. (For 425°C calibration point, adjust millivolt source to 22.15mv at 70°F ambient temperature.) Refer to calibration chart for millivolt settings at other ambient temperatures.
7. Adjust R27 until deviation meter on front panel indicates zero.
8. Repeat steps 1 through 7 until calibration accuracy is achieved at both ends of scale.

Setpoint	ROOM AMBIENT (°F)						
	68	69	70	71	72	73	74
200F	3.89	3.86	3.83	3.80	3.77	3.74	3.71
800F	22.30	22.27	22.24	22.21	22.18	22.15	22.13
100C	4.24	4.22	4.19	4.16	4.13	4.11	4.08
425C	22.21	22.18	22.15	22.12	22.09	22.06	22.03

Figure 1
Calibration Chart

CHECK SloStart OPERATION

1. Set millivolt source to zero.
2. Turn SloStart switch ON. Observe that SloStart lamp blinks and that Load Lamp cycles at approximately 50% duty cycle.
3. Increase millivolt source to point where LOAD cycle lamp turns OFF.
4. Set setpoint control to center Deviation Meter. The control should be between 149 - 185°F. (65 - 85°C).
5. Continue to increase output of millivolt source until the SloStart lamp turns OFF.
6. Set the setpoint control to zero the Deviation Meter. The control should be between 239 - 275°F. (115 - 135°C)
7. Turn the controller OFF and then back ON. Time the SloStart cycle using the counter/timer. The duration of the SloStart cycle should be 5 minutes \pm 20 seconds.

ELECTRICAL PARTS LIST

The FC10G and FC15G series of temperature controllers consist of a family of similar models, each having different operating features. The following electrical parts list is applicable to all types. Components may be deleted or values changed, as indicated, from model to model.

CIRCUIT NUMBER	DESCRIPTION	PART NUMBER
B1	Neon Lamp Ass'y, Amber	2910S20-AMB
B2	Neon Lamp Ass'y, Red	2910S20-RED
C8,C9	Capacitor, Electrolytic, 10uf/16VDC	PDA10M16
C10,C11	Capacitor, Electrolytic, 100uf/16VDC	KSET100-16
C6	Capacitor, Electrolytic, 1uf/50VDC	PDAL1M50E
C3,C4	Capacitor, Tantalum 10uf/16VDC	DP10M16
C5,C14,C16	Capacitor, Ceramic, .01uf/50VDC	DB207Z5P103K
C15,C19	Capacitor, Dipped, .47uf/50VDC	8131M050651474M
C1,C2	Capacitor, Film, .033uf/100V	EM330M1A
C13	Capacitor, Film, .1uf/630V	PMG1000-6A
C18	Capacitor, Ceramic, 100pf/50V	DT201GP101K
CR1,CR10	Diode, Silicon Signal	IN914
CR2-4,11,12	Diode, Silicon Rectifier	IN4002
CR6,CR8	Rectifier, Bridge	PF40
CR7	Diode, Zener, Programmable	TL431CLP
CR9	Diode, Light Emitting	5082-4480
M1	Meter, Deviation, Edgewise	IM36
Q1	Transistor, NPN	2N4401
Q2	Transistor, PNP	2N4403
Q3,Q5	Transistor, Unijunction	2N6028
*Q4	Triac, 25A	Q4025P
R64	Resistor, Carbon Film 470ohm, 5%, $\frac{1}{2}$ W	RAB.25J471
R30	Resistor, Carbon Film, 560ohm, 5%, $\frac{1}{2}$ W	RAB.25J561
R39	Resistor, Carbon Film, 680ohm, 5%, $\frac{1}{2}$ W	RAB.25J681
R48	Resistor, Carbon Film, 1kohm, 5%, $\frac{1}{2}$ W	RAB.25J102
R4,R7	Resistor, Carbon Film, 1.5kohm, 5%, $\frac{1}{2}$ W	RAB.25J152
R15,34,37,52	Resistor, Carbon Film, 2.2kohm, 5%, $\frac{1}{2}$ W	RAB.25J222
R56	Resistor, Carbon Film, 3.3kohm, 5%, $\frac{1}{2}$ W	RAB.25J332
R5,R55	Resistor, Carbon Film, 6.8kohm, 5%, $\frac{1}{2}$ W	RAB.25J682
R8,13,38	Resistor, Carbon Film, 10kohm, 5%, $\frac{1}{2}$ W	RAB.25J103
R57,62,63	Resistor, Carbon Film, 10kohm, 5%, $\frac{1}{2}$ W	RAB.25J103
R9,R54	Resistor, Carbon Film, 22kohm, 5%, $\frac{1}{2}$ W	RAB.25J223
R65-R76	Resistor, Carbon Film, 33kohm, 5%, $\frac{1}{2}$ W	RAB.25J333
R31,40,53	Resistor, Carbon Film, 47kohm, 5%, $\frac{1}{2}$ W	RAB.25J473
R1,32,33	Resistor, Carbon Film, 100kohm, 5%, $\frac{1}{2}$ W	RAB.25J104
R60	Resistor, Carbon Film, 120kohm, 5%, $\frac{1}{2}$ W	RAB.25J124
R3	Resistor, Carbon Film, 220kohm, 5%, $\frac{1}{2}$ W	RAB.25J224
R10,11,12	Resistor, Carbon Film, 1megohm, 5%, $\frac{1}{2}$ W	RAB.25J105
*For FC15G	Triac, 40A	Q4040P

R26,58,59	Resistor, Carbon Film, 1megohm, 5%, $\frac{1}{4}$ W	RAB.25J105
R2	Resistor, Carbon Film, 2.2megohm, 5%, $\frac{1}{4}$ W	RAB.25J225
R44,45,51	Resistor, Carbon Film, 470kohm, 5%, $\frac{1}{4}$ W	RAB.25J474
R14,R50	Resistor, Composition, 22megohm, 10% $\frac{1}{4}$ W	RAD.25K226
R41,R43	Resistor, Composition, 100ohm, 10% $\frac{1}{2}$ W	RAD.5K101
R16	Resistor, Precision, 2.21kohm, 1%, 1/8W	RAN.25F2211D
R22,46,47	Resistor, Precision, 10.0kohm, 1%, 1/8W	RAN.25F1002D
*R28	Resistor, Precision, 10.0kohm, 1%, 1/8W	RAN.25F1002D
R28	Resistor, Precision, 15.0kohm, 1%, 1/8W	RAN.25F1502D
R18	Resistor, Precision, 47.5kohm, 1%, 1/8W	RAN.25F4752D
R19,20,24,25	Resistor, Precision, 100kohm, 1%, 1/8W	RAN.25F1003D
R23	Resistor, Precision, 205kohm, 1%, 1/8W	RAN.25F2053D
R17	Resistor, Precision, 221kohm, 1%, 1/8W	RAN.25F2213D
**R29	Resistor, Variable, 5kohm, 2W	AW20498VC
R35	Resistor, Variable, 10kohm, 3/4W	BM5693
*R27	Resistor, Trimmer, 50kohm	3386X-1-503.
R27	Resistor, Trimmer, 100kohm	3386X-1-104
R21	Resistor, Trimmer, 100kohm	3386X-1-104
R36,R61	Resistor, Trimmer, 10kohm	3386X-1-103
S1	Switch, Rocker, DPDT	2600-13E
S2	Switch, Toggle, DPDT Miniature	ST2-1
*S3	Switch, Thumbwheel BCD	44011S
S4	Switch, Toggle, SPDT Miniature	ST1-1
T1	Transformer, Power	F24-07.5-F-N
U1	Integrated Ckt, Digital	CD4070BE
U2	Integrated Ckt, Linear	LM324N
U3	Integrated Ckt, Linear	OP-07DP
U4	Integrated Ckt, Opto-coupler	4N40
U5	Integrated Ckt, Linear	LM79L05AC
U6	Integrated Ckt, Digital	CD4093BE
U7	Integrated Ckt, Digital	CD4020BE
U8	Integrated Ckt, Digital	MC14001BCP
U9	Integrated Ckt, Digital	CD4016BE
U10	Integrated Ckt, Linear	LF353N
U11	Integrated Ckt, Digital	AD7525KN
U12	Integrated Ckt, Linear	LM747CN
VR1	Varistor, Metal Oxide	V250LA15A

NOTES: *indicates that item is used only on digital units
 **indicates that item is used only on Celsius units

All electrical parts do not appear on all units. Components may be added or deleted to provide specific operating features depending on the model number. Refer to the schematic diagram to identify the components related to each function.

ADDENDA TO PARTS LIST

The following items are replaceable mechanical parts for the model FC10/FC15G Series Temperature Controllers. Although it is unlikely that these parts will require replacement during the normal life of the unit, the following information is provided for servicing convenience.

DESCRIPTION	PART NUMBER
Knob, Setpoint, Fahrenheit	PS95TS-5124-2
Knob, Setpoint, Celsius	PS95TS-5124-3
Knob, % Power	PK50-B-1/8
Handle	A-1594-2
Nylatch Plunger	HN3P-33-4-1
Nylatch Grommet	HN3G-33-1
Analog Dial Lock Thumbscrew	2366
Dial Lock Nylon Flatwasher	5610-37-040
Dial Lock Shoulder Washer	5607-79
Meter Retaining Spring Clip	670-403A

FC SERIES 'G' PC BOARD LAYOUT WITH SLO-START

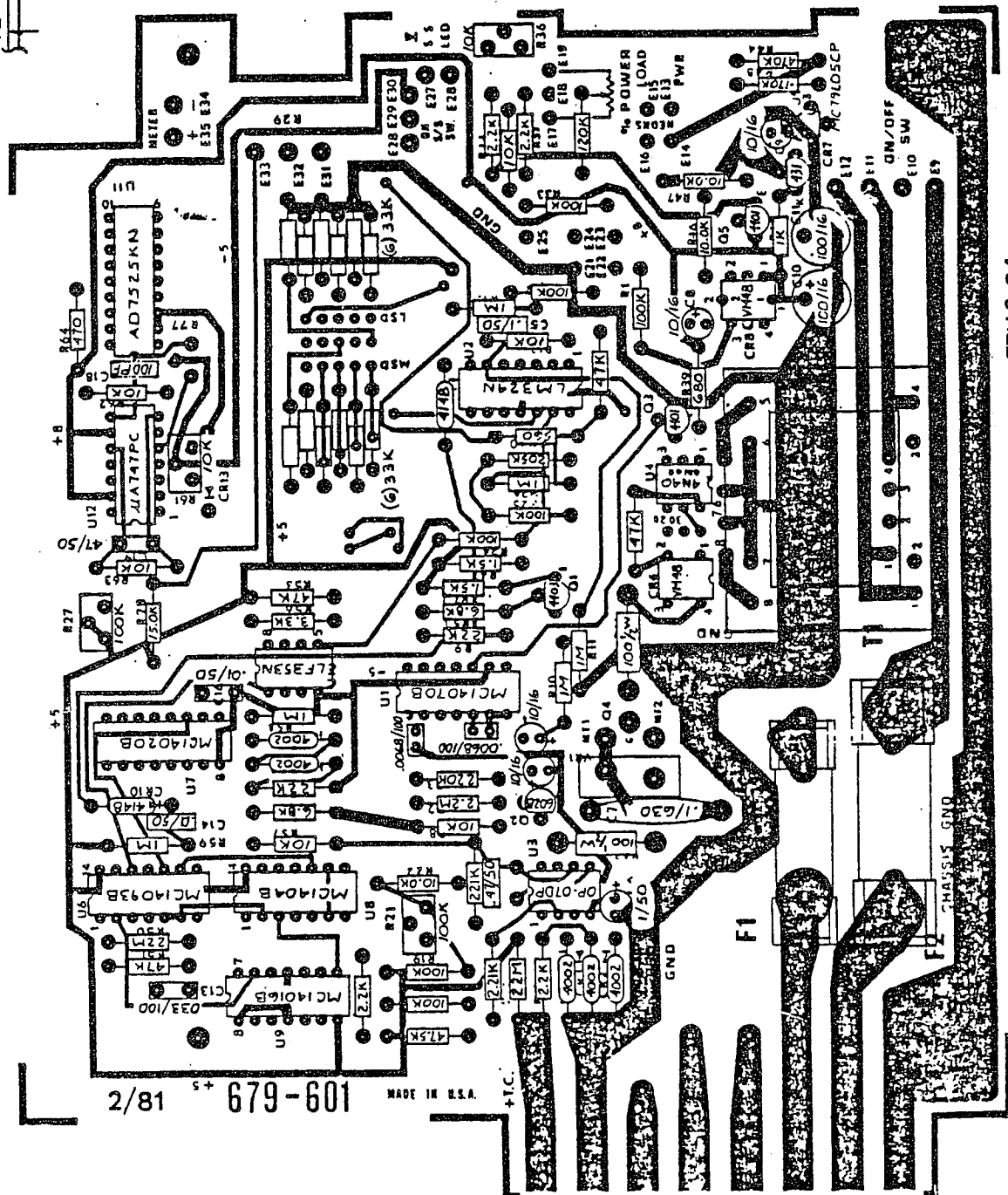
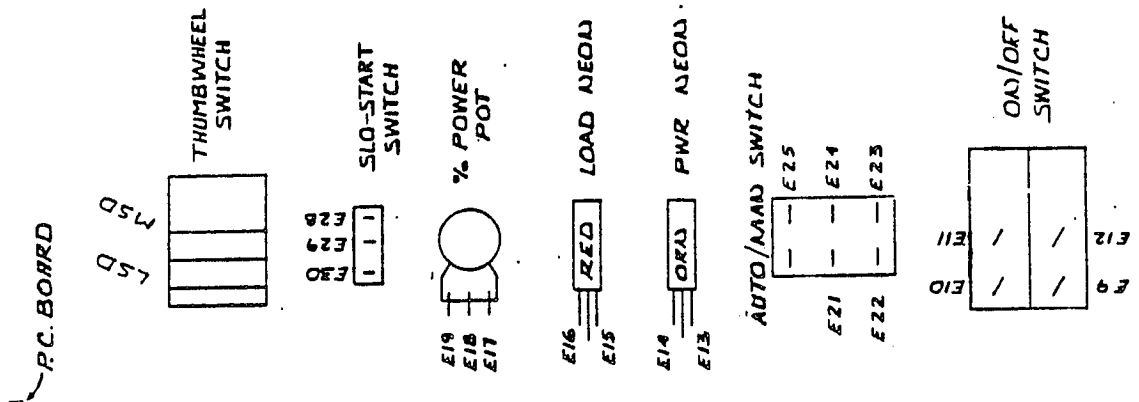
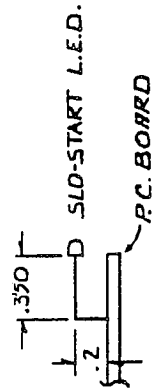

109-679-601 18/2

MADE IN U.S.A.

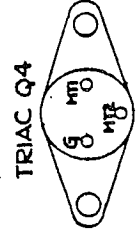

D-M-E COMPANY
NEW PRODUCT ENGINEERING DEPT.
MADISON HEIGHTS, MICHIGAN 48071

PART NAME
FC SERIES 'G'
PC BOARD LAYOUT
WITH SLO-START

DATE

5 4 3 2 1

REVISIONS		DATE	APPVD
ZONE	LTR	CODE	DESCRIPTION

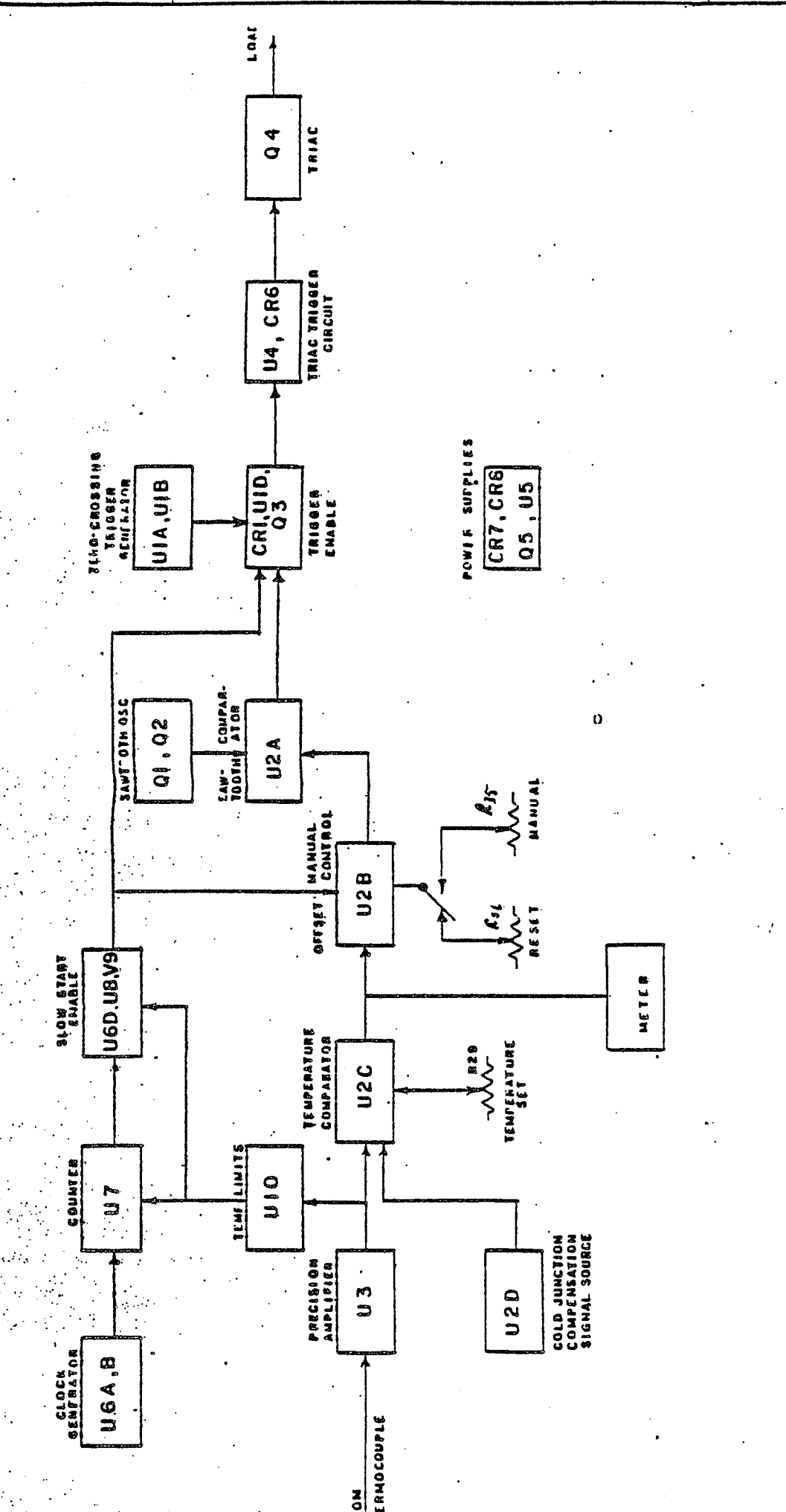

UNIT:	FC 10	DOWN: AP
TITLE:	BLOCK DIAGRAM	APPVD:
DWG NUMBER:		DATE: 6-23-81
		SCALE: —
		SHT: 7

REV. NO.	DATE	DESCRIPTION
1	7-17-67	INITIAL ISSUE
2	7-17-67	REVISED: R30 WAS R40N1; ADDED C20 ACROSS R50; TABLE III: U2 (A-S) WAS PIN#14; U2 (L-S) WAS PIN#7
3		DESIGNATED DIGITAL ONLY, II-5 ANALOG ONLY, SLO-START BI ONLY AREAS (CIRCLED)
4		71 PRIMARY CONNECTIONS SCHEMATIC
5		RMS WAVE, AC 240V, TERMINAL M19
6		RMS WAVE, AC 240V, TERMINAL M19
7		R35 J52 CHANGED TO SWITCH/POD, ASSY.
8		ADD CR17/R17E

- NOTES: 1. UNLESS OTHERWISE SPECIFIED, ALL RESISTORS ARE 1/8W, 5%.
2. EARTH (COMMON) GROUND
3. SIGNAL GROUND
4. PC BOARD ASSY. 879-60N
5. PAL-OPT IS THE SECOND SOURCE FOR U4. ALTERNATE ASSY. IS A LATCH WITH A J26P CAPACITOR ACROSS PINS 9 AND 8.
6. ALTERNATE VENDORS FOR U4 ARE: SIBINETICS NO. J4747C OR MOTOROLA NO. MC10102C
7. CR15 AND R77 FOR TEST PURPOSE ONLY.
8. RESISTOR VALUE MAY VARY FROM 2% OHMS TO 1% OHMS. 1% IN THE NET TO BE THE SAME VALUE.
9. ALTERNATE CIRCUIT IS INDICATED BY DOTTED LINES AND JUMPERS WHEN U4 IS REPLACED BY MOC3020.
10. * DESIGNATES PRECISION VALUES 1%.

REVISED PRINT

THIS PRINT SUPERSEDES ALL PREVIOUS ISSUES. PLEASE RETURN OR DESTROY ALL PRINTS WITH LOWER LOWER LETTER.

PREVIOUS REVISION: DATE:
 REVISION: DATE:
 LATEST REVISION: DATE:
 APPROV: DATE:
 JUL 20 1967

D-M-E COMPANY
 1000 UNIVERSITY AVENUE, SUITE 100
 BOSTON, MASSACHUSETTS 02116

PROJECT NAME: EC-G SERIES
 SCHEMATIC CONTROLLER

DATE: 7-17-67
 DRAWING NO.: 67P-501001

RELEASED FOR PRODUCTION JUL 20 1967

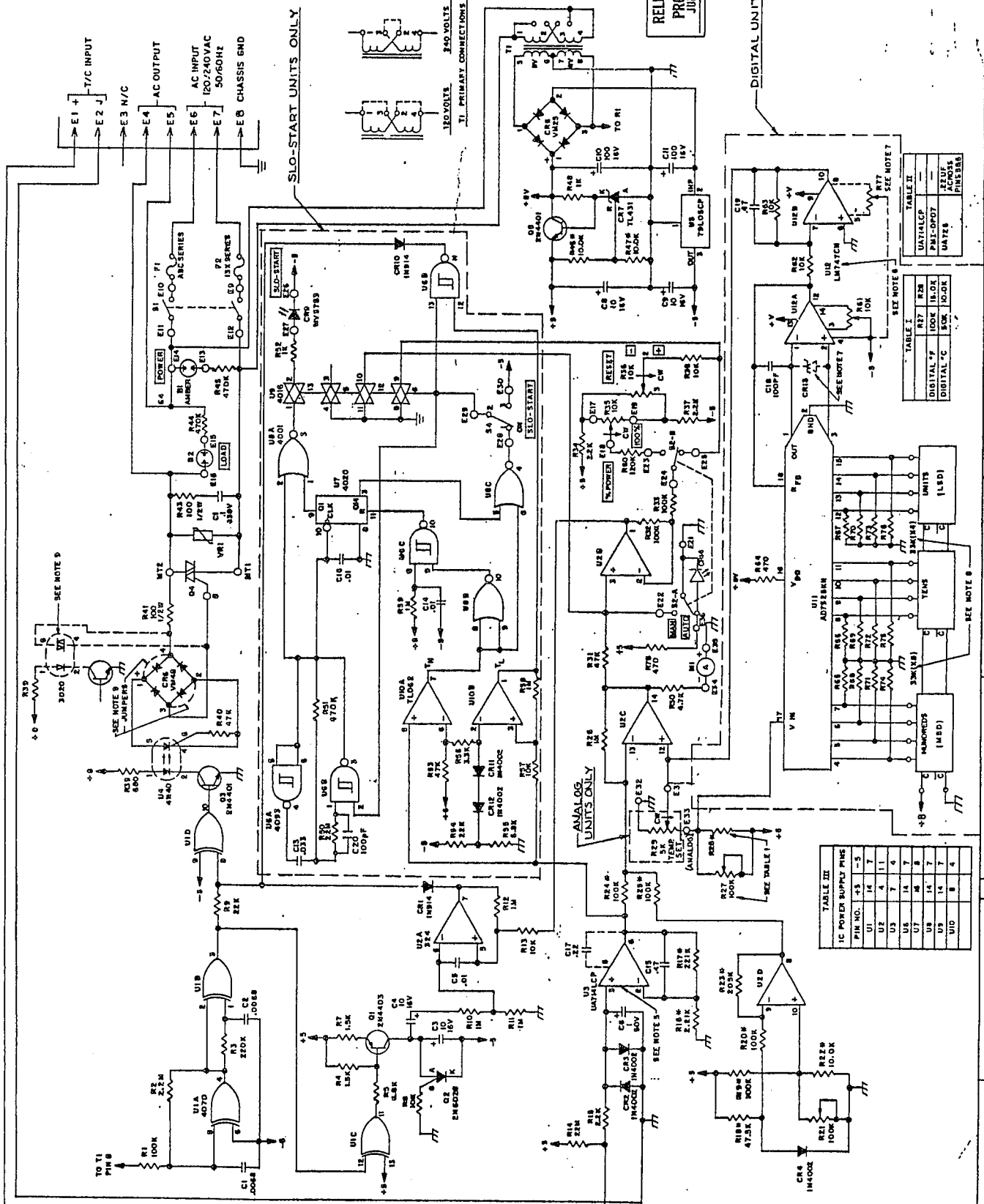

TABLE III
 IC POWER SUPPLY PINS

PN NO.	A-S	L-S
U1	14	7
U2	4	11
U3	7	9
U4	14	7
U5	14	7
U6	14	7
U7	14	7
U8	14	7
U9	14	7
U10	8	4

TABLE I
 DIGITAL *P
 DIGITAL *C

LOCK	18-0K	100K
R26	10K	100K
R27	10K	100K
R28	10K	100K

TABLE II
 ANALOG
 PAL-OPT
 LATCH

220K	100K	10K
R18	10K	10K
R19	10K	10K
R20	10K	10K
R21	10K	10K
R22	10K	10K
R23	10K	10K
R24	10K	10K
R25	10K	10K

FC-10A9 SERIES

TO CONVERT FROM 240V
TO 120V

- ① CUT TRACE (COPPER ETCHING)
WHERE INDICATED BY X
- ② SOLDER JUMPERS (2) WHERE
INDICATED BY A & B

