

MFP1G, MFP1G1, MFPR2G, MFFPR2G & MFHP1G D-M-E Smart Series[®] Mainframes

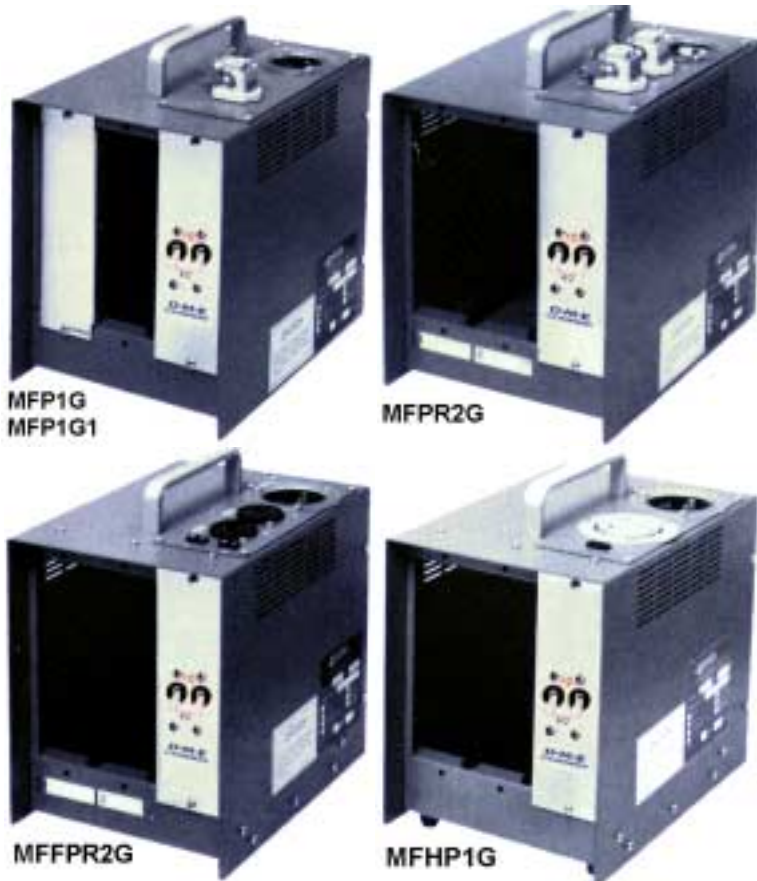

User's Manual D-M-E Company

Copyright © D-M-E Company 1999-2000. All rights reserved.

D-M-E Company products are covered by USA and foreign patents, issued and pending. Information in this publication supersedes that in all previously published material. Specifications and any changes are reserved.

Printed in the United States of America

D-M-E Company
29111 Stephenson Highway
Madison Heights, MI 48071

D-M-E Company and D-M-E are registered trademarks of D-M-E Company.

WARRANTY

D-M-E Company warrants that this product will be free from defects in materials and workmanship for a period of one (1) year from the date of shipment. If any such product proves defective during this warranty period, D-M-E Company, at its option, will either repair the defective product without charge for parts and labor, or will provide a replacement in exchange for the defective product.

This warranty shall not apply to any defect, failure or damage caused by improper use or improper or inadequate maintenance and care. D-M-E Company shall not be obligated to furnish service under this warranty a) to repair damage resulting from attempts by personnel other than D-M-E Company representatives to repair or service the product; b) to repair damage resulting from improper use or connection to incompatible equipment; or c) to service a product that has been modified or integrated with other products when the effect of such modification or integration increases the time or difficulty of servicing the product.

SAFETY

D-M-E Company products have been designed to be safe and simple to operate. As with any electronic equipment, you must observe standard safety procedures to protect both yourself and the equipment.

To Prevent Injuries:

- To avoid electrical shock or fire hazard, DO NOT apply voltage to a terminal that exceeds the range specified for that terminal.
- To avoid electrical shock, make sure product is properly earth grounded.
- To avoid mechanical injury, electrical shock or fire hazard, DO NOT operate this product with covers or panels removed.
- To avoid mechanical injury, electrical shock or fire hazard, turn off power (circuit breaker) before inserting or removing modules.
- To avoid electrical shock or fire hazard, DO NOT operate this product when wet.
- To avoid injury or fire hazard, DO NOT operate this product in an explosive atmosphere.

To Prevent Product Damage:

- DO NOT operate this product from a power source that applies more than the voltages specified.
- Replace 15 amp fuses in your modules with 10 amp or less fuses for use in 10 amp mainframes.

UNPACKING AND INSPECTION

1. After unpacking, inspect your mainframe and check for any damage that may have occurred during shipment.
2. Check the circuit breaker for damage.
3. Check for proper operation of circuit breaker by flipping breaker on and off with no voltage applied.
4. Check power output connector and thermocouple input connector for any physical damage.
5. Check AC input power wiring.

SAFETY

SERVICE AND INSTALLATION OF THIS EQUIPMENT SHOULD ONLY BE PERFORMED BY QUALIFIED SERVICE PERSONNEL FAMILIAR WITH HIGH VOLTAGE ELECTRICAL CIRCUITS.

NOTE: FOLLOW ALL NATIONAL AND LOCAL ELECTRICAL CODES WHEN CONNECTING THIS EQUIPMENT.

WARNING: Before removing the back panel of this unit, remove the AC power input cable. **DO NOT** apply power to this cable or the unit when the back panel is removed.

DANGER: **DO NOT** connect AC power input cord to your in-plant power distribution system until mainframe back panel is securely in place.

DANGER: **DO NOT** attempt to insert lower voltage modules into high voltage zones. Certain catastrophic failure of the module and possible injury to humans in the area may result.

DANGER: On models equipped with a module rejection system, **DO NOT** attempt to defeat the rejection scheme as certain catastrophic failure of the module and possible injury to humans in the area may result. **DO NOT** remove the rejection rod on any modules or mainframes. (See figures 4 & 5)

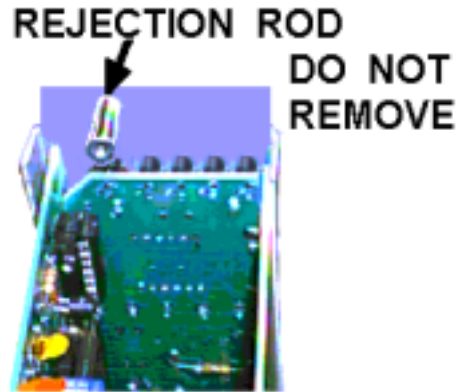

Figure 4 - Rejection Rod on Low Voltage Modules (DO NOT Remove)

High power mainframes are equipped with a safety rejection rod to prevent accidental insertion of non-compatible modules and to prevent short circuits. **DO NOT** remove the rejection rod, as certain catastrophic failure will occur. (See figure 5)

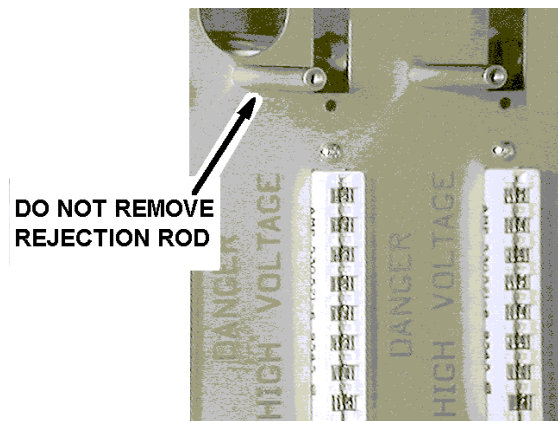

Figure 5 - Rejection Rod In MFHP1G High Power Mainframe (DO NOT Remove)

DANGER - HIGH VOLTAGE

If it becomes necessary to service this equipment after AC input connections are completed, make sure that your in-plant power disconnect is secured in the "OFF" position by means of a padlock or other mechanism provided by the manufacturer of the disconnect. A "**LOCK-OUT**" mechanism is recommended to prevent power from being accidentally turned-on.

INSTALLATION

1. You are installing a piece of electronic equipment that is delicate and should not be subjected to any physical or environmental abuse. Select a cool, dry, well-ventilated, environmentally clean location, away from heat, moisture and liquid carrying lines, i.e.: water cooling hoses, hydraulic hoses, etc.
2. Mainframes are shipped from the factory pre-wired 240 VAC. MFP1G1 units are wired for 120 VAC input.
3. Select the input supply line wire size according to national and your local electrical codes. Refer to mainframe serial number label for amperage rating of the circuit breaker in your mainframe.
 - a) Assemble your AC input power supply line to the input power connector supplied with your mainframe.
 - b) **WARNING:** Make sure that the chassis has been earth grounded before applying power.
4. Make sure mainframe back panel is securely in place before connecting power to mainframe.
5. Route AC input cable to a branch circuit (service) disconnect switch and attach leads to fused side of switch. Be sure ground lead is attached to a good earth ground.
6. Where required, insert appropriate fuses in fused disconnect box.
7. Connect power & thermocouple cables to mainframe and mold.
8. Refer to Module Specifications sheets supplied with module for front panel controls and module operation for the specific module being used.

WARNING: BEFORE APPLYING POWER, MAKE SURE ALL NATIONAL AND LOCAL

ELECTRICAL CODES HAVE BEEN FOLLOWED AND ALL SAFETY PRECAUTIONS ARE TAKEN.

IMPORTANT: For mold wiring and heater connection information, refer to mold connector-wiring diagram.

OUTPUT CURRENT LIMITATIONS

Each Smart Series mainframe is equipped with a two-pole, fast-acting magnetic circuit breaker, (see figure 6). This circuit breaker limits the current in the mainframe and protects the mainframe internal wiring. The output current limitation for each frame is determined by the size of the circuit breaker installed in the mainframe. DO NOT use a larger amperage breaker than what your mainframe was designed for. Serious damage can occur.

MODEL NUMBER	CIRCUIT BREAKER
MFP1G	10 AMP
MFP1G1	10 AMP
MFPR2G	20 AMP
MFFPR2G	30 AMP
MFHP1G	30 AMP

WARNING: BEFORE INSERTING OR REMOVING ANY MODULES FROM THE MAINFRAME, TURN THE POWER "OFF" BY FLIPPING THE CIRCUIT BREAKER HANDLE TO THE "OFF" POSITION.

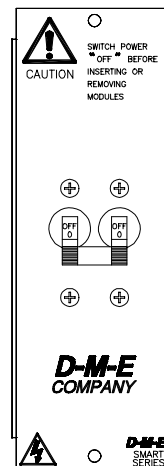

Figure 6 - Circuit Breaker Panel

MAINFRAME WIRING

Provided in this booklet, is a schematic of standard 1 & 2 zone mainframes & 1 zone high power mainframe (see figures 13 & 14). Refer to edge connector for printed circuit board connections (see figure 7). Note that the AC input power contact's #6 and #7 on the edge card connector are specifically designated for 240 VAC (120 VAC in MFP1G1 units).

The module output power is connected to the mainframe power output connector, located on the top of the mainframe, via contact's #4 and #5 of the edge card connector. (See figure 7)

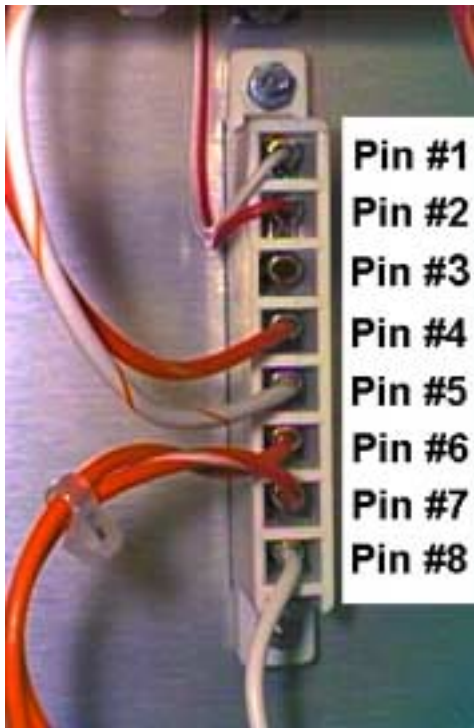

Figure 7 - Rear View of Edge Card Connector

Thermocouple (T/C) input is accomplished by connecting a thermocouple signal to the input connector located on the top of the mainframe, (see figure 1). The T/C signal is attached to the appropriate module via T/C extension wires connecting the T/C input connector to contacts #1 and #2 on the appropriate module edge card connector. Refer to figure 7, and note that thermocouples are connected to contact #1 which is positive (white wire), and contact #2 which is negative (red wire).

PIN ASSIGNMENTS OF THE EDGE CARD CONNECTOR:

Please refer to figure 7 for location of pins.

- Pin 1** From Thermocouple Positive (+)
- Pin 2** From Thermocouple Negative (-)
- Pin 3** (not used)
- Pin 4** To Heater Load
- Pin 5** To Heater Load
- Pin 6** From Applied Line Voltage
- Pin 7** From Applied Line Voltage
- Pin 8** From Earth Ground

TEMPERATURE CONTROL SYSTEM CONSIDERATIONS:

There are many factors to consider when employing a temperature control system. All power requirements should be examined to make sure that the control system is matched to the heaters that are used:

1. Are the heaters 240 VAC or 120 VAC?
2. What is the wattage of the heater? Is the module's output amperage capability adequate for the heater to be controlled?
3. Is the control system sized adequately for all heaters that need to be controlled?

TEMPERATURE CONTROL THEORY CONSIDERATIONS:

In any temperature control system, it is important to minimize the lag time between the heat source (heater) and the heat sensor (thermocouple). The lag time is the time it takes for the heat to travel from the heater to the thermocouple. It is very important to keep the physical distance between the heater and the thermocouple at a minimum. Best results are obtained when the heater and thermocouple are in an integral unit, such as D-M-E's "HCTC" series heaters. The greater the distance between the heater and thermocouple, the greater the control error.

Make sure that the heater to be used has adequate power (wattage) to elevate the

material to be heated to the desired temperature.

If you have any questions or require additional information, contact your local D-M-E representative.

CONNECTORS AND CABLES:

D-M-E inventories mold power cables and thermocouple cables that interface with 1 & 2 zone mainframes, and 1 zone high power mainframes. See Figure 12. They are also available in special lengths on request.

TERMINAL MOUNTING BOXES:

D-M-E also inventories terminal mounting boxes to provide an easy and economical method of mounting the power / thermocouple connectors on the mold.

ACCESSORIES TO COMPLETE YOUR MOLD DESIGN:

To complete your temperature control system, the following accessories are suggested:

- ◆ Mold power input & thermocouple output connector and panel mount base, (see figure 8).



Figure 8 - Mold Power Input Connector

- Mold power cables in 10-foot or 20-foot lengths (see figure 9).



Figure 9 - MPTC-10 Power & Thermocouple Cable

- ◆ Temperature control modules. **NOTE: TEMPERATURE CONTROL MODULES ARE NOT INCLUDED WITH THIS MAINFRAME; THEY MUST BE ORDERED SEPARATELY.** One module is required for each zone of temperature control. Any of D-M-E's standard 15 Amp temperature controllers will operate in the 10 or 15 Amp mainframes. 30 Amp modules are required for high power mainframes.
- ◆ For safety considerations, all unused zones must be covered with blank panels. Use one D-M-E #MFBP10G blank panel for every zone that is not used.

REPLACEMENT PARTS:

Replacement parts listed below:

CATALOG NUMBER	DESCRIPTION
ABC10	10 Amp fuse
ABC15	15 Amp fuse
AGC1	1 Amp fuse
CBD10M	10 Amp Circuit Breaker
CBD20M	20 Amp Circuit Breaker
CBD30M	30 Amp Circuit Breaker
CKF312G	Edge card connector kit (connector & 8 pins)
MFBP10G	Blank panel to cover unused zones
RPM0044	Card guide
RPM0046	Replacement pins for edge card connector
RPM0048	Extraction tool for edge card connector pins



Figure 10 - Edge Card Connector Kit, CKF312G (includes pins). Use RPM0046 to order pins separately.

TROUBLESHOOTING:

If the fuses in a module clear upon initial power up or the circuit breaker trips, the heater output is probably grounded or shorted.

FAN FUSES:

The MFFPR2G and the MFHP1G mainframes both have 2 additional fuses located on the backside of the rear connector panel. These fuses supply voltage to both wires of the fan. (1 fuse for each wire.) If the fan stops rotating, check these fuses. You can access the fuses by disconnecting the power and then removing the back panel. **DO NOT WIRE CONTROL ZONES TO THESE FUSES. USE EXACT REPLACEMENT FUSES.**

EUROPEAN CONFORMITY (CE) REQUIREMENTS:

Secure each DME module, at the top of the module, to the mainframe, with a green 3MM x 10MM screw that is supplied with each module. Modules are secured to the mainframe for grounding purposes and also satisfying CE requirements. When the modules are screwed down securely, they are CE compliant. **NEVER REMOVE OR INSERT MODULES WHEN MAINFRAME CIRCUIT BREAKER POWER IS ON.**

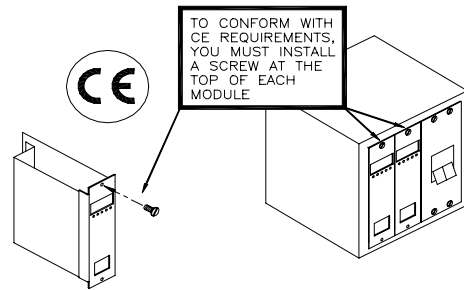

Figure 11 - European Communities Conformity Requirement

CAUTION! FOR USERS OF THE MFP1G, MFP1G1, & MFPR2G MAINFRAMES

If you ordered an MFP1G, MFP1G1, or an MFPR2G mainframe, you must replace the standard ABC15, 15 Amp fuses, supplied with your DME modules, with ABC10, 10 Amp fuses. The connectors and wiring in these mainframes are only rated for 10-Amp usage. If you use 15 Amp fuses in your modules, you risk damage to the mainframe, the modules, and perhaps to persons who work near this unit while it is in operation. Be safe by replacing the fuses with ABC10 fuses.

RETURN POLICY:

The D-M-E® 1 & 2 zone mainframes are warranted for 1 year parts and labor, excluding fuses.

Contact D-M-E Customer Service for return authorization for repairs or warranties. Replacement parts are also available through the Customer Service Department.















D-M-E Customer Service

In U.S., West Coast: 1(323) 263-9261
Elsewhere in U.S.: 1(800) 626-6653
In Canada: 1(905) 677-6370

SERVICE CENTER U.S.A.

D-M-E WORLD HEADQUARTERS
29111 STEPHENSON HIGHWAY
MADISON HEIGHTS, MICHIGAN 48071
PHONE: 1(800) 626-6653
TELEFAX: 1(248) 398-6174

G-Series®, Smart Series®, Smart Start®, Selective Cycle®, and D-M-E® are all registered trademarks of D-M-E Company.

MODEL #	Frame	AC Power Inlet	Power Output & T/C Input	Power Input & T/C Output	Power & T/C Cable
MFP1G1 1 Zone 10 Amp 120V					
MFP1G 1 Zone 10 Amp 240V					
MFPR2G 2 Zone 10 Amp/Z 240V					

	Frame	AC Power Inlet	Power Output	T/C Input	Power Input	T/C Output	Power Cable	T/C Cable
MFFPR2G 2 Zone 15 Amp/Z 240V								
MFHP1G 1 Zone 30 Amp 240V								

Figure 12 –Mainframes, Connectors & Cables for All Mainframes

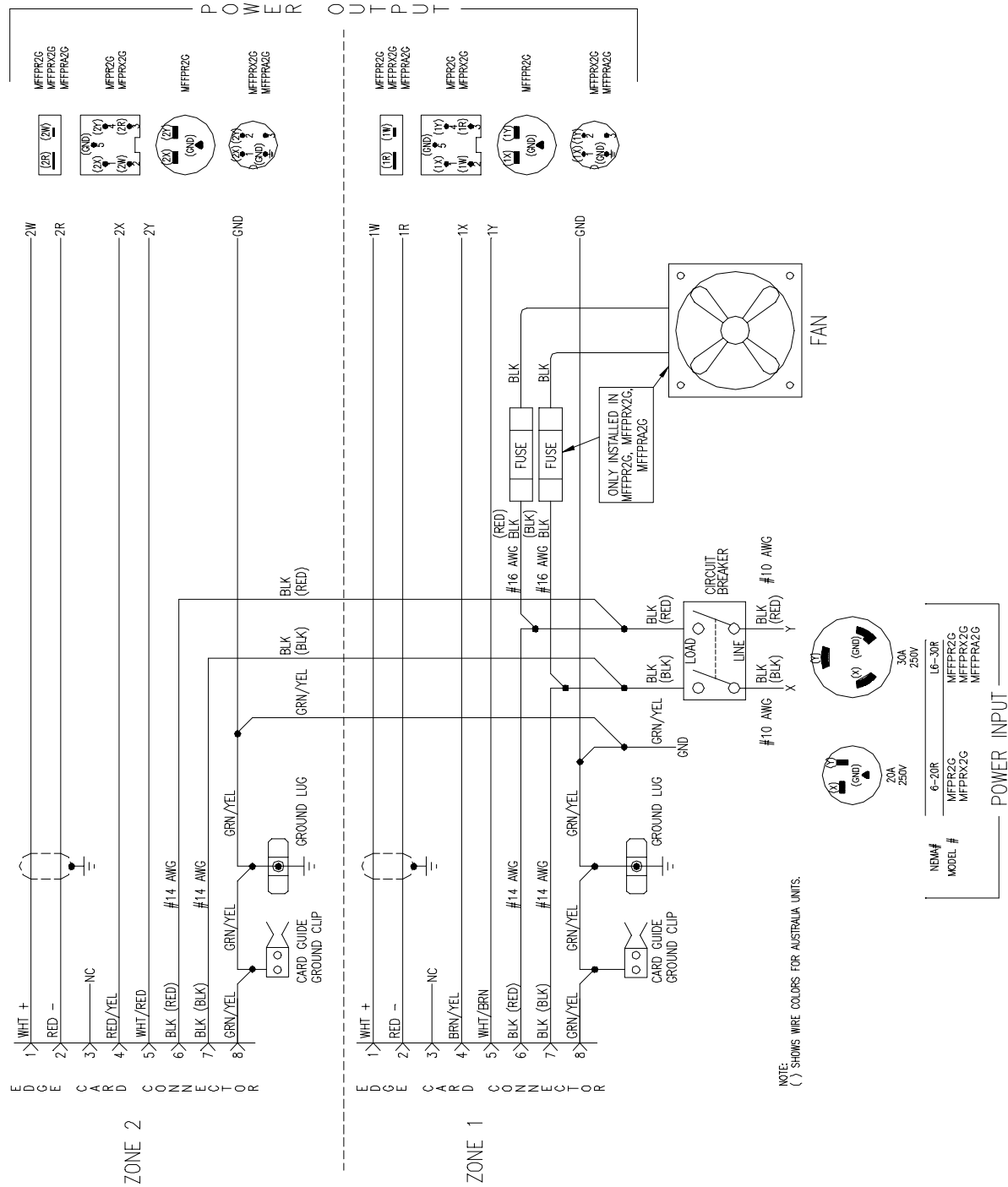

Figure 13 - 1 & 2 Zone Mainframes Wiring Schematic

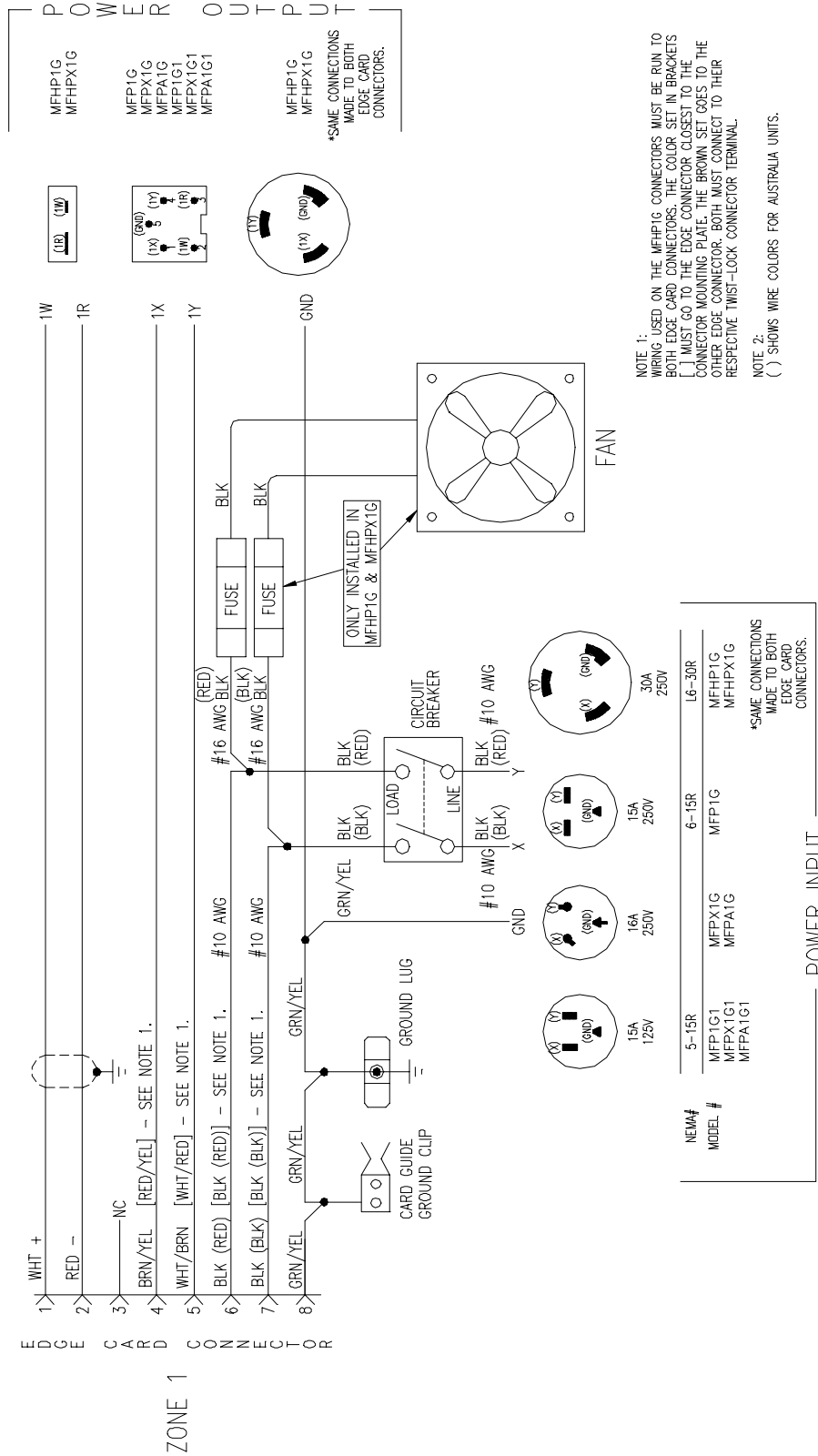

Figure 14 - 1 Zone High Power Mainframe Wiring Schematic

NOTES:

ECN'S:

ECN-0525 Feb 14, 2000
Correct figure 5 to show pin inserted for position 3
Correct figure 7 to show pin inserted for position 3
Correct figure 10 to show pin for position 3
Page 9, Table, change 7 pins to 8 pins
Update figures 13 & 14 to show correct Australian wire colors

APPROVAL:

SENIOR PRODUCT ENGINEER: _____ DATE: _____

MANAGER OF ELECTRONICS: _____ DATE: _____