

Quick Strip™ Ejection System

The New Standard
for Part Ejection

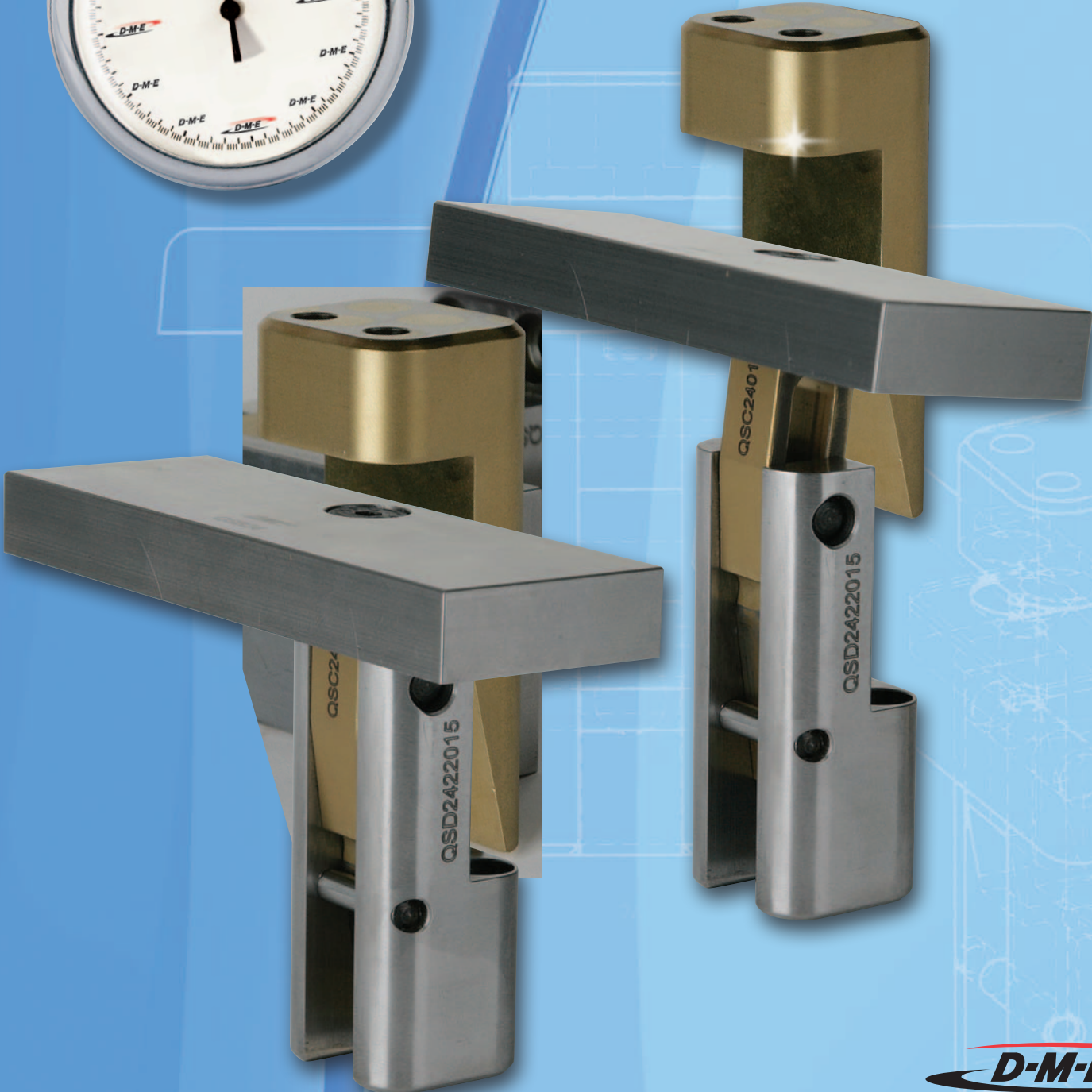

Quick Strip

MAXIMIZING UPTIME AND COST SAVINGS

Quick Strip is the new standard in part ejection

With its ability to cut up to half the time and cost required with traditional ejection, Quick Strip is the new standard for part ejection. Mold construction is simplified with Quick Strip because there is no need to focus on the design, machining and operation of ejector housings. No ejector retainer plate. No ejector plate. No ejector holes to be machined and reamed.

The elimination of ejector plate actuation results in faster mold cycle times. Elimination of the ejector plates and ejector risers significantly reduces material costs for the mold base and results in shorter mold heights, thus allowing molds to be run in smaller presses. Elimination of ejector pins allows for better placement of more cooling channels, resulting in improved cooling and dramatically shorter mold cycle times. Because Quick Strip uses fewer moving parts to achieve part ejection, mold maintenance requirements are reduced, resulting in maximized uptime of the mold. A highly innovative feature of Quick Strip is that the system is actuated by the opening of the mold. This provides the design freedom to install Quick Strip on the moving or stationary side of the mold.

Quick Strip's many benefits are further optimized when used in stack molds and tandem molds.

Advantages of the Quick Strip Ejection System

- Eliminates ejector plates, ejector pins and risers
- Reduces mold height
- Shortens cycle time
- Optimizes cooling process
- Minimizes ejector marks on molded parts
- Minimizes maintenance costs
- Simplifies mold design and construction
- Suitable for use on either the fixed or stationary half
- Each Quick Strip unit can serve multiple cavities
- Multi-purpose design makes Quick Strip suitable for virtually any type of process, including injection molding, die casting and rubber molding

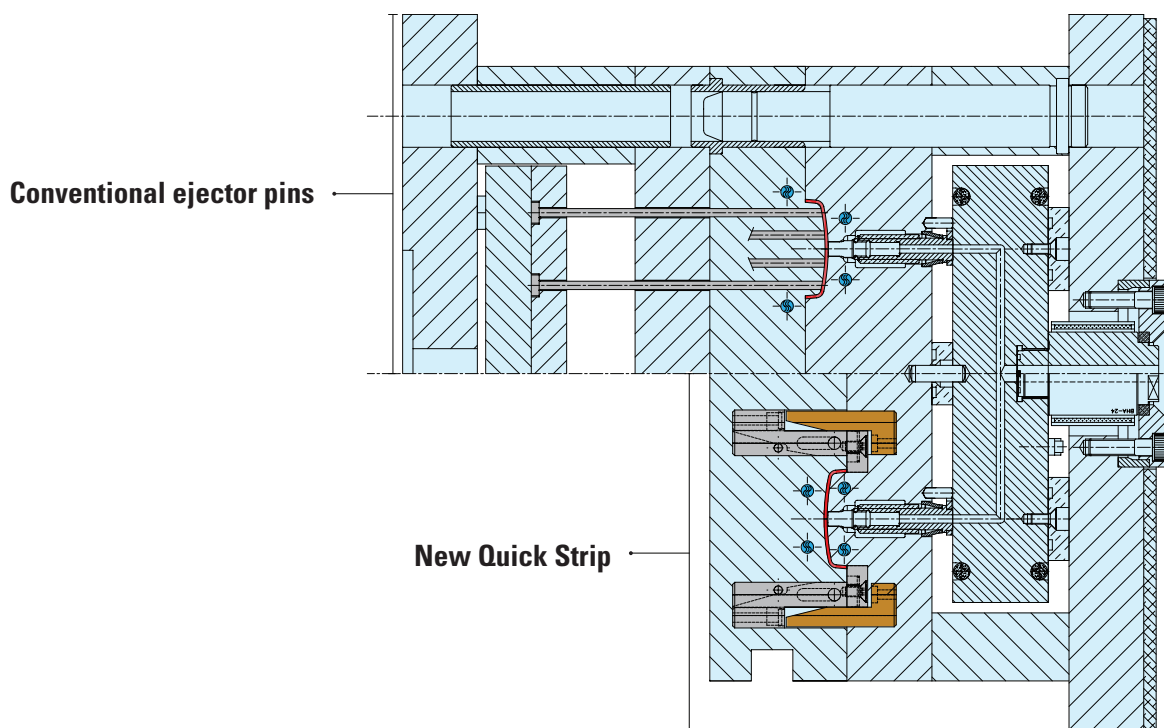

Quick Strip

HOW IT WORKS

The Quick Strip is activated entirely by the opening and closing of the mold and does not rely upon machine strokes, such as the ejector stroke, for its actuation. Below, a four-step sequence shows the Quick Strip during the mold open sequence. The upper images show Quick Strip in its entirety and the lower images show Quick Strip via section views.

- 1) The Quick Strip Assembly consists of a Body, Puller and Spoon that are mounted on the cavity side of the mold, plus a Finger which is mounted on the core side. With the mold closed, the Spoon fits into a machined pocket on the core side, underneath the part cavity. On the parting line side, the Spoon is machined to form a portion of the parting line and part cavity.

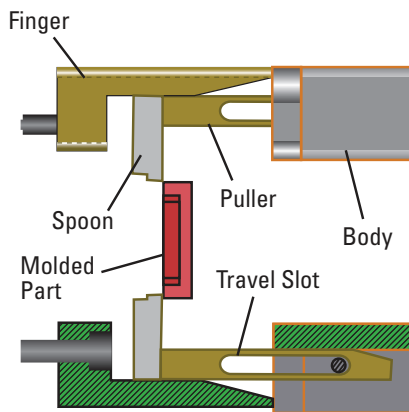

- 2) As the mold opens, the molded part is stuck to the core side of the mold. The Spoon, which is sandwiched between the core side and the molded part, remains in the core side of the mold during the initial mold opening movement.

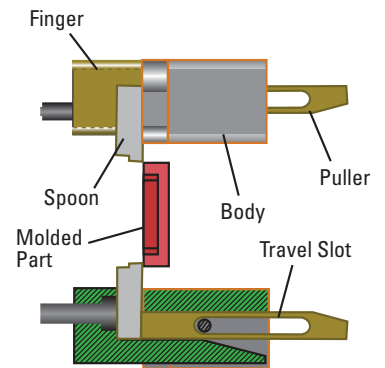

- 3) As the Puller reaches the end of its travel slot, it pulls the Spoon away from the core side. This action also pulls the molded part off the core side. Part ejection is achieved with a pulling motion along the perimeter of the molded part, rather than a pushing action at discrete points along the interior of the molded part. Furthermore, this pulling action occurs during the mold open sequence, rather than during a separate ejector stroke.

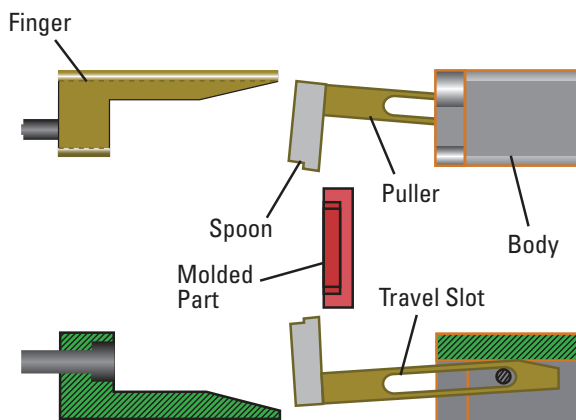
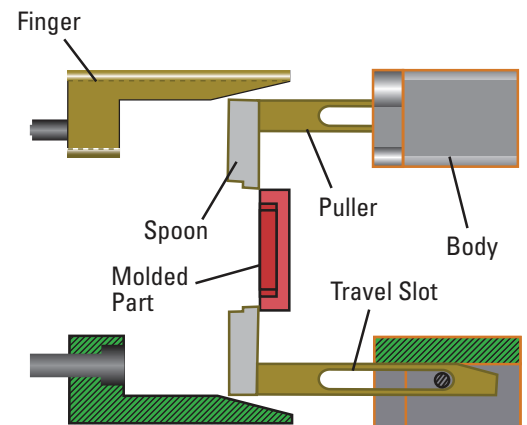

- 4) The final motion of the Spoon is a small rotation away from the part. This small rotation separates the Spoon from the molded part while ensuring that the Spoon is clear of any robotic action that may be necessary to grab the molded part. The rotating movement is defined by the cam angle at the base of the Puller.

- 5) During mold closing, the Finger ensures that the Spoon rotates back to its proper position and is reset into the machined pocket on the core side of the mold as the mold closes.

Since the motion of mold open and close actions are relative, the core side of the mold may be mounted on either the stationary or moving side of the platen.

Visit www.dme.net/quickstrip for a CAD animation

U.S. 800-626-6653 ■ Canada 800-387-6600 ■ www.dme.net

Quick Strip

Unit 24 x 22 mm, 24 x 30 mm - stroke = 15 mm

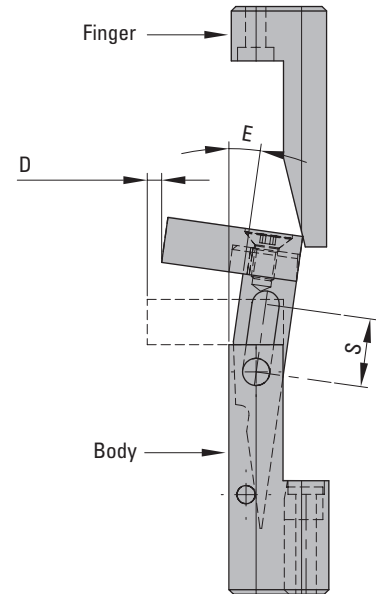
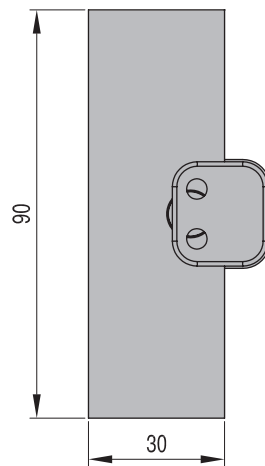
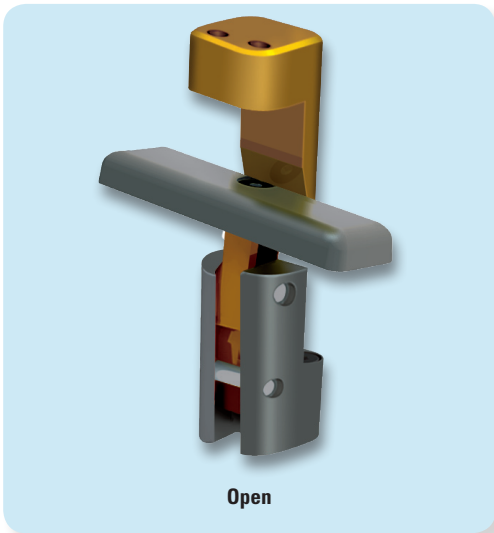
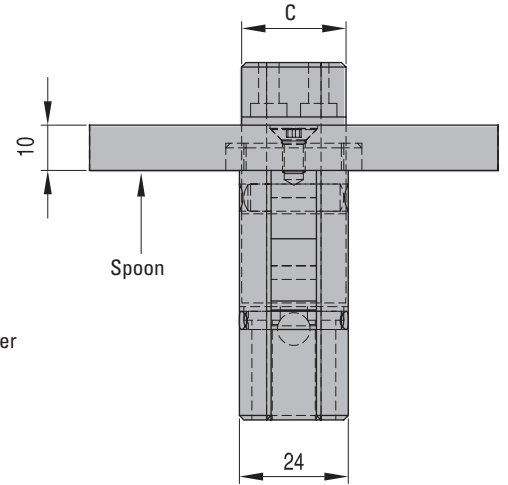
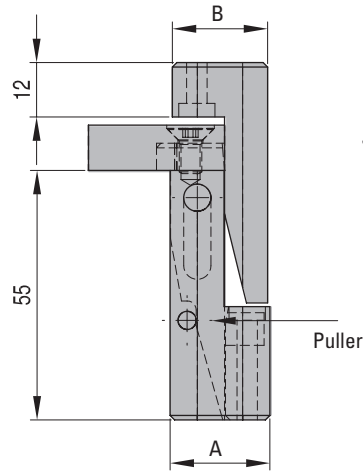
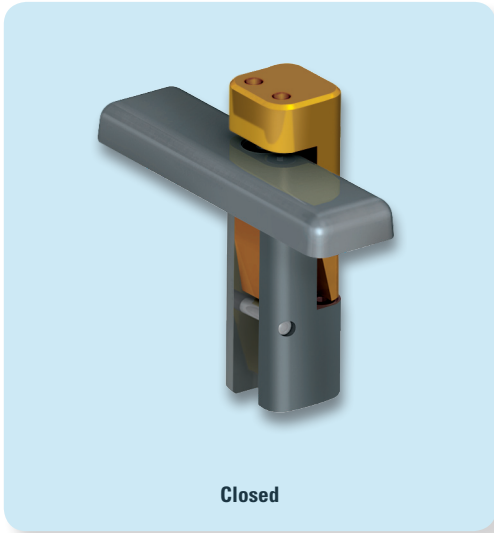

Quick Strip patent pending

Spoon to be adjusted by moldmaker to fit mold and product contour.
Standard material type 1.2312 (comparable to P-20-modified); other steel types available upon request.

Item Number	A	B	C	D	E	S
QS2422015	22	21	23	3.16	8°	15
QS2430015	30	28	22	6.25	15°	15

Quick Strip

Unit 28 x 31 mm - stroke 40-100 mm

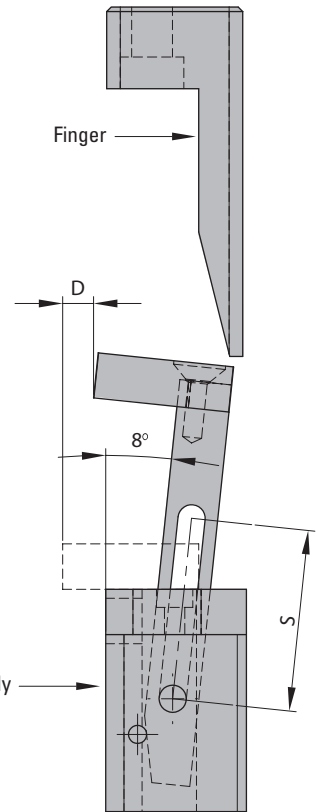
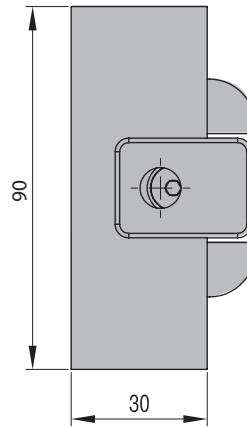
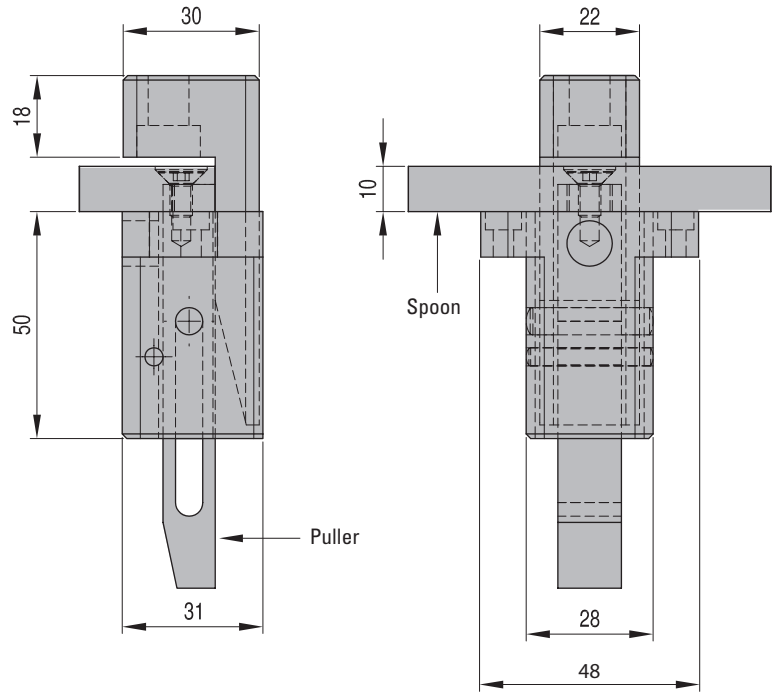
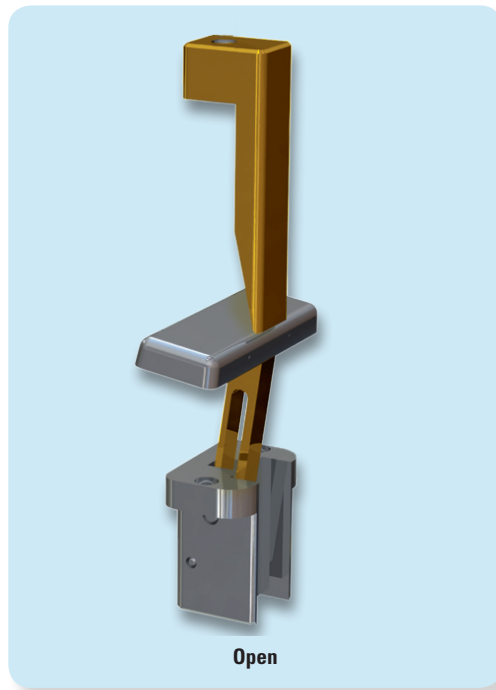
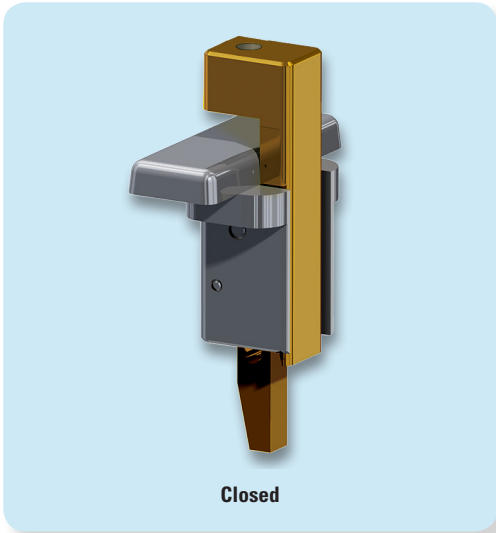

Spoon to be adjusted by moldmaker to fit mold and product contour.
Standard material type 1.2312 (comparable to P-20 modified), other steel types available upon request.

REF	D	S
QS 28 31 040	6.84	40
QS 28 31 060	5.93	60
QS 28 31 080	5.48	80
QS 28 31 100	4.35	100

Quick Strip patent pending

Quick Strip/Traditional Ejection Cost Comparison

Save up to 50% in time and cost with Quick Strip!

Traditional Ejection



Traditional ejector stroke increases cycle time.

Quick Strip Ejection System



Quick Strip is actuated by the opening of the mold; reset by the closing of the mold.

MOLD WITH QUICK STRIP EJECTION SYSTEM						
MACHINING (Milling/Drilling)						
Make electrodes (rough/finish machining)	\$7,005.60					
Mold (fixed half)	\$3,113.60			QUANTITY: Quick Strip	8	
Mold (moving half)	\$3,113.60					
Machining Quick Strip "spoon"	\$1,868.16	QTY	8	Cost of machining "spoon"	\$233.52	per piece
Assembly	\$3,113.60					
Purchase cost of Quick Strip	\$9,340.80	QTY	8	Purchase cost	\$1,167.60	per unit
Plates (fixed half)	\$3,113.60					
Plates (moving half)	\$3,113.60					
TOTAL	\$33,782.56					

MOLD WITH TRADITIONAL EJECTION						
Moving half with ejector plates						
MACHINING (Milling/Drilling)						
Make electrodes (rough/finish machining)	\$7,005.60					
Mold (fixed half)	\$3,113.60			QUANTITY: Ejector Pins	40	
Mold (moving half, not including ejector plates)	\$9,340.80					
Ejector plates	\$2,335.20					
Purchase ejector pins	\$498.00	QTY	40	Purchase cost	\$12.45	per piece
Machining ejector pins:						
3D to match product contour and anti-rotation	\$4,981.60	QTY	40	Machining to match contour	\$124.54	per piece
Plates (fixed half)	\$3,113.60					
Plates (moving half)	\$3,113.60					
Ejector base plate	\$1,401.12					
Ejector retainer plate	\$1,401.12					
Assembly	\$6,227.20					
TOTAL	\$42,531.44					

Quick Strip/Traditional Ejection Overview

Quick Strip Cost Advantages

Quick Strip application cost = \$33,782.56
 Traditional Ejection application cost = \$42,531.44 } Quick Strip is 21% less expensive than Traditional Ejection in this representative application comparison.

Quick Strip machining time: Quick Strip requires 46% less machining time than Traditional Ejection in this representative comparison. In addition to the cost and machining time reductions that Quick Strip enables vs. Traditional Ejection, Quick Strip, on average requires almost 50% less maintenance because it uses fewer moving parts in the part ejection process.

Quick Strip

COST SAVINGS REALIZED WITH THE QUICK STRIP EJECTION SYSTEM

Material Cost Savings - *Quick Strip eliminates the entire Ejector Housing!*

- Eliminates the need for:
 - Ejector Housing Rails
 - Ejector Plate and Ejector Retainer Plate
 - Limit Switch
 - Guided Ejection Guide Pins and Bushings
 - Ejector Plate Knock-Out Rod and Quick Disconnect Coupling
 - Support Pillars and Support Plate
 - Ejector Pins, Ejector Sleeves, Ejector Blades

Mold Design Cost Savings - *simplified mold design equals big savings!*

- Ejector System can be on either the "A" side or "B" side
- Simplified Ejector System design improves part removal
- Optimized cooling channel design means shorter mold cycle times
- Quick Strip Systems are highly effective in multi-cavity molds
- Quick Strip can be used in a variety of processes including:
 - Multi-shot molding
 - Compression molding
 - Rubber molding
 - Die casting
- Quick Strip is ideally suited for multi-parting line molds including:
 - Stack molds
 - Spin stacks, cube stacks, etc.
 - Tandem molds

Machining Cost Savings - *fewer or no Ejector Components means less machining!*

- Eliminates machining for:
 - Ejector Plate and Ejector Retainer Plate drilling, boring, or counter-boring
 - Ejector Pin and Ejector Sleeve drilling and reaming
 - Ejector Blade wire EDM
 - Ejector Pin, Sleeve, and Blade part geometry contouring
 - Guided Ejection drilling, boring, or counter-boring
- Simplifies boring for Optimized Cooling Channels on "B" side

Mold Cycle Time Savings - *cycle times are reduced!*

- Ejector Stroke is eliminated
- Mold Open Stroke can be shortened
- Part solidification time is reduced as ejector force is spread out
- Cooling is improved through optimized cooling channel design on "B" side

Injection Machine Cost Savings!

- Mold height is reduced, possibly permitting the use of a smaller press

Mold Maintenance Cost Savings!

- No Ejector Pins, Sleeves and Blades, and no Guided Ejection means no cleaning and no replacement of worn components

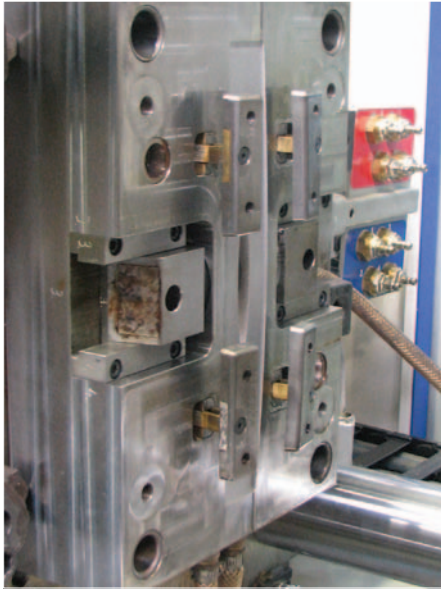

Customers Enjoy Quick Strip's Cost Savings and Part Quality Improvements

*"When **D-M-E** presented the new concept to **Deva**, we were immediately interested. Although the **Quick Strip** was still on the design table for standardization, we immediately saw the enormous advantages and hence wanted to participate in the pilot project as well. The mold was intended for the Airbus and obviously had to meet all quality requirements. Concerning the aesthetic aspect, for instance, ejector marks couldn't be visible. We managed to achieve this requirement through the use of **Quick Strip**, without using ejector pins. Moreover, the shortening of the mold construction and production time were decisive factors.*

*During the trials the injection was not optimal, yet the product stayed in the mold. Where possible damage (and repair costs) from ejector pins could occur, the solid construction of the **Quick Strips** rendered an excellent service. Above all, thanks to **D-M-E** we have managed to make considerable savings on mold construction with **Quick Strip** compared to our previous construction with an ejector package.*

*Therefore, **Deva** is particularly happy about the collaboration with **D-M-E**. We are also happy that we were able to participate in this revolutionary product right from the start. Whenever possible, **Deva** will certainly use **Quick Strip** in the future as well."*

Dirk Schmeling
General Manager

Deva Kunststoff-Technik GmbH
Lemgo, Germany

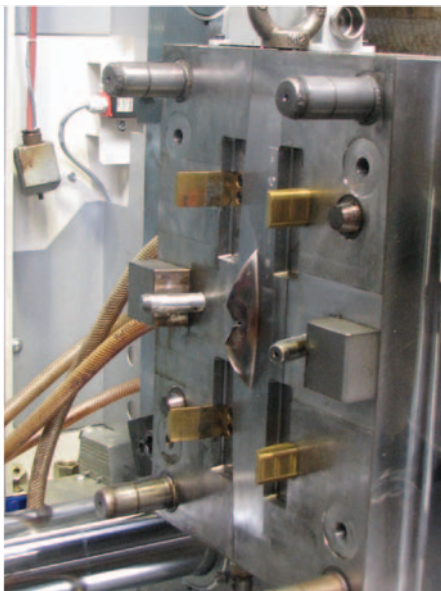

*"**Hans Kroner Formenbau**, together with **Deva** and **D-M-E**, has used the newly developed **Quick Strip**. The aesthetically high-quality component for the Airbus A380 fits this purpose perfectly. Both the application in the mold construction and the actual use of the mold went off problem-free. This new ejector system can be used in many cases, especially when ejector marks can't be visible. **Hans Kroner Formenbau** will support this new ejector system and hopes for a successful introduction in the market."*

Hans Kroner Formenbau
Schloss Holte-Stukenbrock, Germany



World Headquarters

D-M-E Company
29111 Stephenson Highway
Madison Heights, MI 48071
800-626-6653 toll-free tel
248-398-6000 tel
888-808-4363 toll-free fax
www.dme.net web
appl_eng@dme.net e-mail

D-M-E of Canada, Ltd.

6210 Northwest Drive
Mississauga, Ontario
Canada L4V 1J6
800-387-6600 toll-free tel
905-677-6370 tel
800-461-9965 toll-free fax
dme_canada@dme.net e-mail

D-M-E Europe C.V.B.A.

Industriepark Noord
B-2800 Mechelen Belgium
32-15-215011 tel
32-15-218235 fax
sales@dmeeu.com e-mail