

D-M-E

INSTALLATION DATA
 AIR POPPET VALVES - METRIC
 Please read carefully before installing components

STEP #1 - DIMENSIONS FOR MACHINING POCKET FOR AIR POPPET VALVES

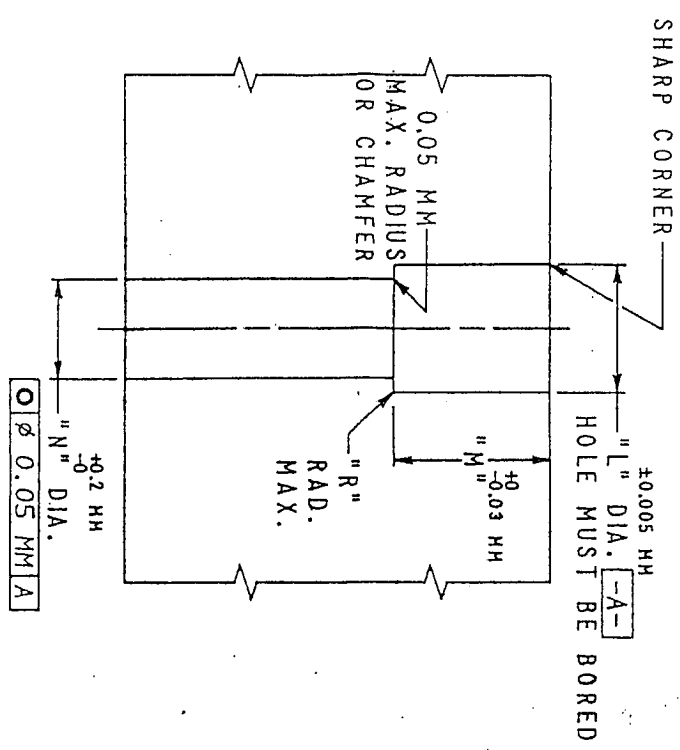

CATALOG NUMBER	"L" DIA.	"M" DEPTH	"N" DIA.	"R" RAD. MAX.
VA-01	8	11	6.75	0.1
VA-02	12	18	9	0.2
VA-03	18	22	14	0.3

ALL DIMENSIONS ARE IN MILLIMETERS

STEP #2 - PRESS AIR POPPET VALVE INTO POCKET

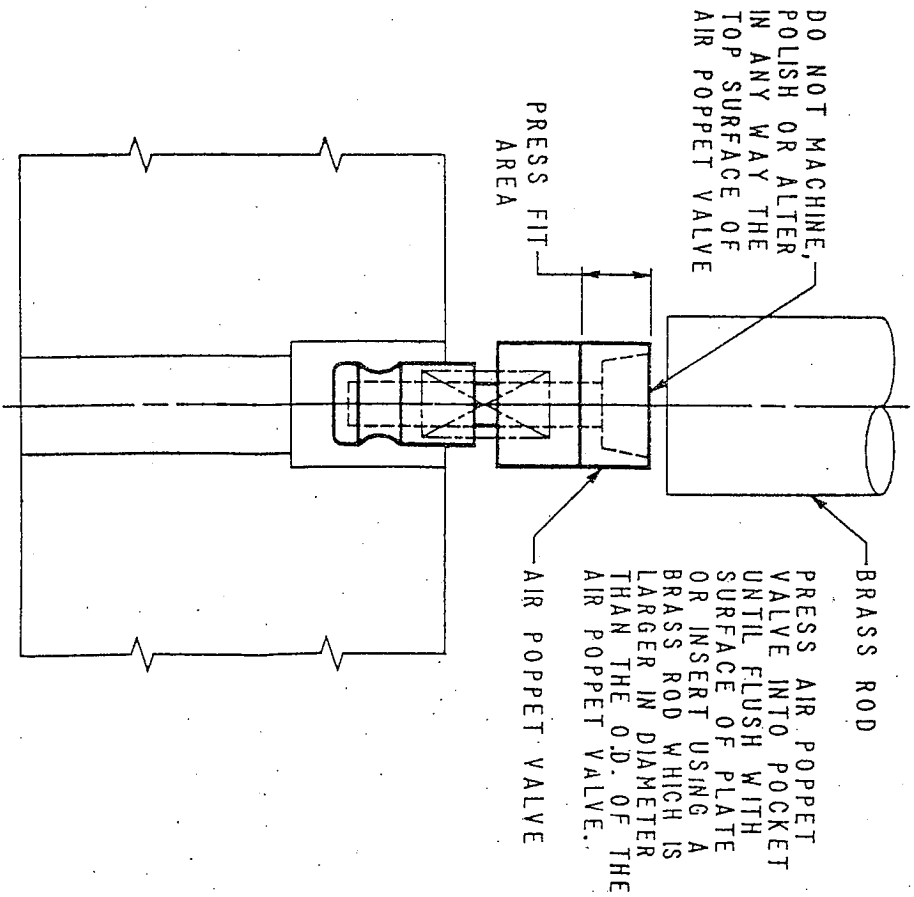

NOTE:
 TYPICALLY, THE PRESS FIT SPECIFIED IS SUFFICIENT TO HOLD THE AIR POPPET VALVE IN THE POCKET. HOWEVER, FOR SOME APPLICATIONS OR WHEN THE HOLE HAS BEEN BORED TOO LARGE OR THE AIR POPPET VALVE POCKET, IT MAY BE NECESSARY TO USE A LOCKING TYPE COMPOUND TO SECURE THE AIR POPPET VALVE IN THE POCKET OF THE PLATE OR INSERT. CARE MUST BE TAKEN TO MAKE SURE THAT LOCKING COMPOUND ONLY MAKES CONTACT WITH THE O.D. OF THE ASSEMBLY.

AIR POPPET VALVES - METRIC

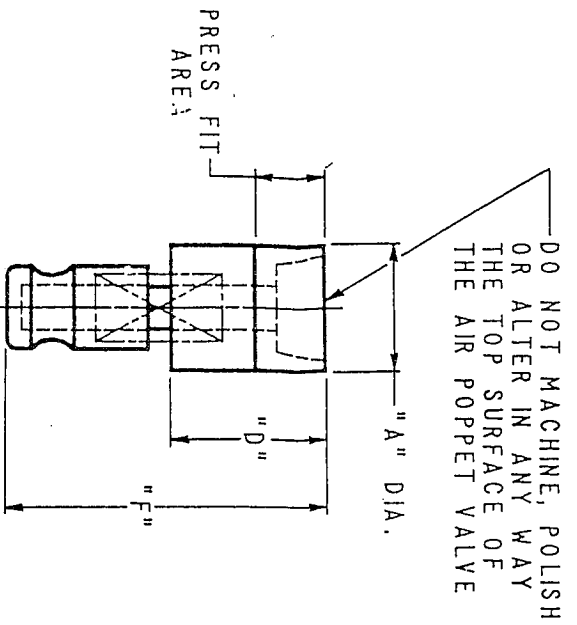

CATALOG NUMBER	"A" DIA.	"D" LENGTH	"F" O.A.L.
VA-01	8	11	24
VA-02	12	18	34
VA-03	18	22	45.5

ALL DIMENSIONS ARE IN MILLIMETERS

NOTE:
AIR POPPET VALVES ARE SUPPLIED ONLY AS COMPLETE ASSEMBLIES. THE SPRING HOUSING HAS BEEN SECURELY CRIMPED TO THE STEM OF THE VALVE TO PREVENT THE COMPONENTS FROM SEPARATING. NO ATTEMPT SHOULD BE MADE TO TAKE THE COMPONENTS APART OR THE UNIT WOULD BE DAMAGED BEYOND REPAIR.



29111 STEPHENSON HIGHWAY
HADISON HEIGHTS, MICHIGAN
48071 U.S.A.
1-800-626-6653

TYPICAL AIR POPPET VALVE INSTALLATIONS IN MOLDS

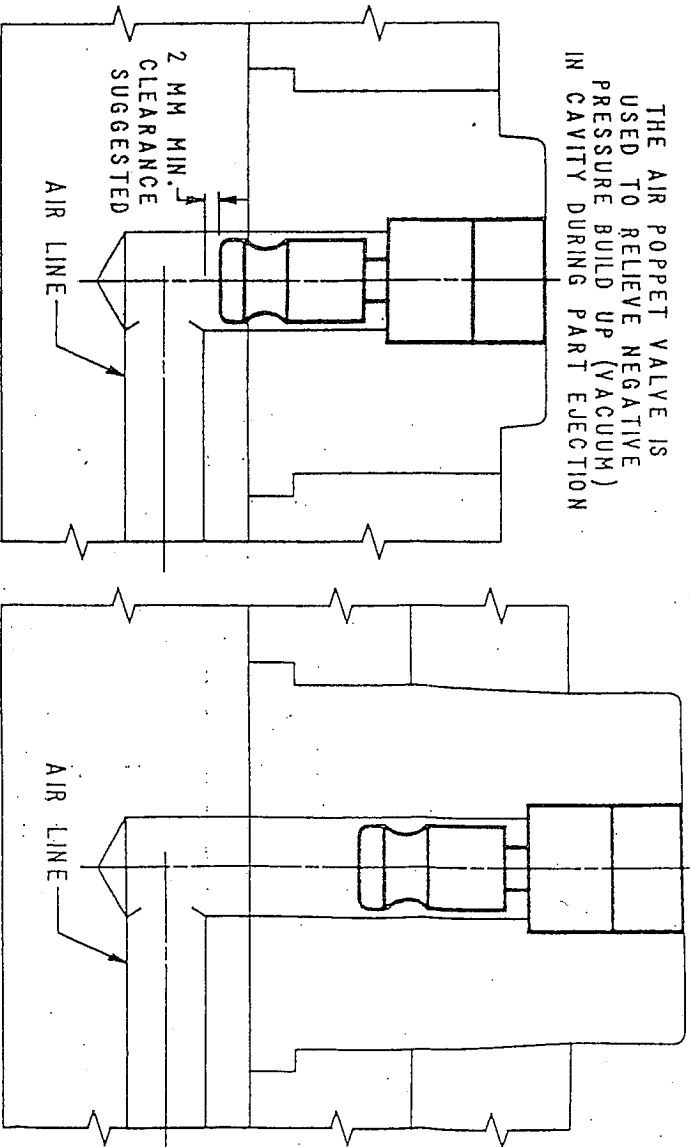

STANDARD "A" SERIES
MOLD BASE INSTALLATION
(EJECTOR PINS REQUIRED
FOR PART EJECTION)

"X" SERIES STRIPPER PLATE
MOLD BASE INSTALLATION
(STRIPPER PLATE REQUIRED
FOR PART EJECTION)

OPERATION AND INSTALLATION NOTES:

1. ACTIVATE PRESSURE TO AIR LINE OF AIR POPPET VALVE AND MACHINE EJECTION AT THE SAME TIME. THIS WILL ALLOW AIR POPPET VALVE TO RELIEVE THE NEGATIVE PRESSURE BUILD UP (VACUUM) IN THE CAVITY DURING EJECTION OF THE PART FROM THE MOLD.
2. THE CONTROL VALVE USED TO CONTROL THE FLOW OF AIR TO THE POPPET VALVE MUST FULLY RELEASE ALL AIR TO THE ATMOSPHERE AT THE END OF EACH CYCLE SO THAT THE AIR POPPET VALVE CLOSES FULLY. THE AIR POPPET VALVE MUST NEVER BE HELD OPEN EVEN SLIGHTLY WHILE PLASTICS MATERIAL IS BEING INJECTED INTO THE MOLD OR DAMAGE COULD OCCUR TO BOTH THE AIR POPPET VALVE AND THE MOLD. MOLDER OR MOLDMAKER TO SUPPLY CONTROL VALVES AND LIMIT SWITCHES TO SUIT.
3. THE AIR POPPET VALVE IS NOT INTENDED TO BE USED AS THE SOLE EJECTION MEANS OF REMOVING PARTS FROM THE MOLD. MATERIAL SHRINKAGE AND OTHER ASPECTS CAN PREVENT IT FROM WORKING IN THIS MANNER.