

ME-0741-PS-991-D

08-08

RG6/IS

**SERIES 625  
RING GATE NOZZLE  
MACHINING &  
INSTALLATION DATA**



NOTE: Dimensions are shown in Inches.

NOTE: Before installing a Ring Gate Nozzle, it is important to take the nozzle's expansion factor into consideration. For best results, please follow the information below

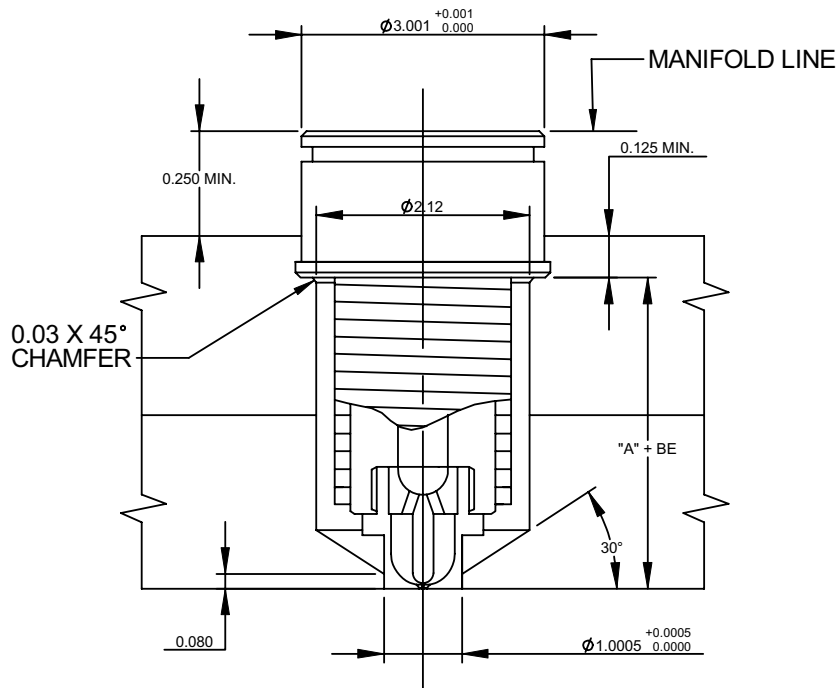

To compensate for the nozzle's growth when heat is applied, the linear expansion of the nozzle (BE) at a given temperature must be added to the nominal "A" dimension. The formula below shows how to figure boring depth (dimension "A" + BE). The tip of the nozzle will now be flush with cavity line.

Formula for determining this expansion factor is as follows:  
 $BE = \text{"A" dimension} \times 0.00000633 \times (\text{Nozzle set point temperature} - 68 \text{ } ^\circ\text{F})$ .

EXAMPLE: Given a 3 inch "A" dimension, with a nozzle set point temperature of 500 °F:  
 $BE = 3 \times 0.00000633 \times (500 - 68) = 0.008$   
 Thus "A" + BE will be 3.008

Note: The above information is only given as an example. variations may occur based on mold configurations and cooling factor. In some instances it may be necessary to obtain an empirical factor.

NOZZLE SUB-ASSEMBLY CATALOG NUMBER	"A" DIMENSION FOR NOZZLE ASSEMBLY
EHA 0016	4.000
EHA 0017	5.000
EHA 0018	6.000
EHA 0019	7.000
EHA 0020	8.000
EHA 0021	9.000
EHA 0022	10.000

**RING GATE TIP SUB-ASSEMBLY**

CATALOG NUMBER	EHT 0040
----------------	----------

NOTE: Nozzle Assembly requires Nozzle Sub-assembly and Tip-assembly.

**SERIES 625  
RING GATE NOZZLE  
MACHINING &  
INSTALLATION DATA**

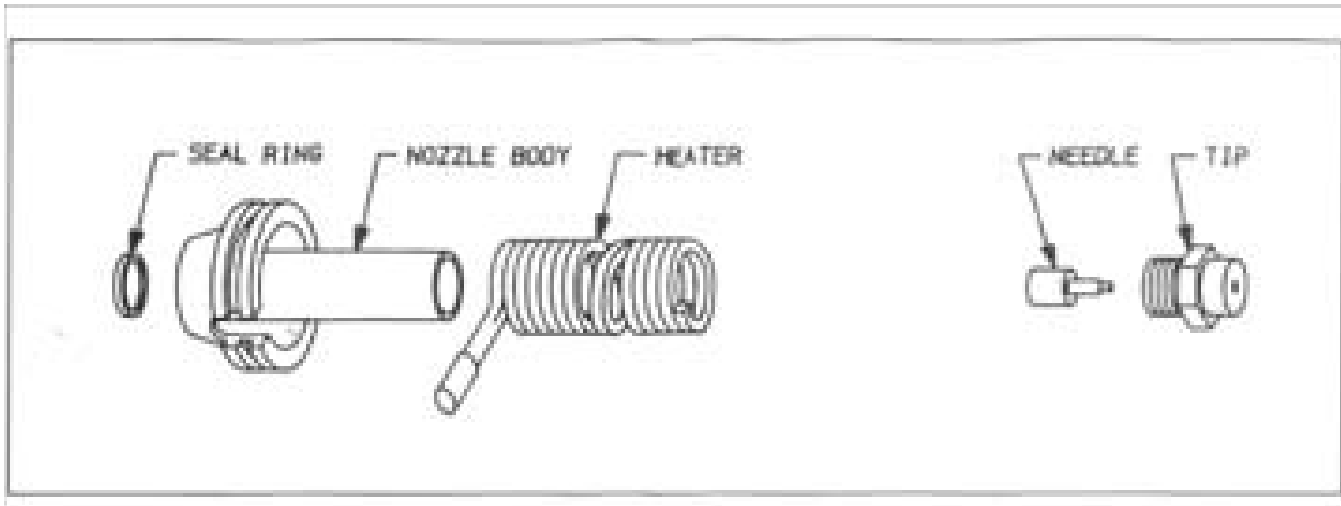

### OPERATING & SERVICING INSTRUCTIONS FOR NOZZLE SERIES 250, 375, & 625

All interchangeable nozzles are similar, and differ only in size and material flow capacity. The information found below applies to the nozzle series 250, 375 & 625.

#### OPERATING PROCEDURE

The nozzles are supplied with a Square (Flat) Coil equipped with a Type J Thermocouple. It is recommended to use a D-M-E closed loop Temperature Controller for optimum Temperature Control. When starting the nozzle, set the temperature to 10% voltage if using in open loop manual type or to 200 °F if using closed loop automatic type. In either case this procedure will allow the heater to dissipate any moisture. Make sure you maintain this start-up setting for 15 minutes. Controller equipped with Step Smart ®, Smart Step ® or other heater warm-up circuitry will change automatically. It is essential to use controllers with the proper voltage and wattage capabilities. The voltage and wattage of each heater is clearly marked on the heater tag.

Step Smart ®, Smart Start ® and DME ® are all registered trademarks of DME Company.

#### ASSEMBLY PROCEDURE - "ALL PARTS MUST BE CLEAN"

1. Apply an anti-seize compound on both the heater cover and tip threads.
2. Install the heater using a Square Coil Heater wrench (Wrench included with replacement heater). After the heater is installed, it should cover the entire length of the nozzle body - stretch the heater by hand if necessary.
3. Firmly screw the tip sub-assembly into the shank of the nozzle body. Tighten and untighten two or three times making sure there is a good contact between the tip and the shank. Torque to approximately 30 ft-lbs.

#### DISASSEMBLY PROCEDURE

1. Place the nozzle in a vice using "V" Block, then secure it firmly at the nozzle head.
2. For removal of tip from nozzle, a six point deep well socket is recommended. The nozzle must be at processing temperature and the heater should be turned off when removing tip counter-clockwise from the nozzle. If nozzle is still in the mold, the nozzle must be "keyed" to prevent wire damages.
3. Tip must be cleaned of any material before reassembling.
4. Remove the heater using a Square Coil Heater wrench (Wrench is included with replacement heater).
5. Cast-in heater may be removed if failure occurs and replaced with a Square Coil Heater. Follow assembly procedures for Square Coil Heater.

#### IMPORTANT SAFETY INFORMATION

A hot-runner system includes electrical elements and may contain molten plastic at elevated temperature and pressure. To avoid injury, exercise caution by reading these instructions before servicing or operating the system.

These instructions must be passed on to the end user where they should be read before using this product. Failure to do so can result in serious injury or death.



Failure to comply will result in serious injury or death:

#### ELECTRICAL HAZARDS

Improper voltages or grounding can result in electrical shock. Use only with proper voltage and a proper earth ground. To avoid electrical shock, do not operate product when wet. Do not operate this equipment with covers or panels removed. To avoid electrical shock, turn off main power disconnect and lockout / tag out before servicing this device. Do not connect temperature sensors to electrical power. It will damage the product and it could cause fire, severe injuries or even death. If green ground wire present wire must be connected to the ground. Do not rebend rigid leads. Rebending leads might result in damage to circuit. Product might absorb moisture when cool. Use low Voltage or power to drive out residual moisture before applying full power. Failure to do so may cause damage to this product.



Failure to comply can result in serious injury or death:  
**STORED ENERGY AND HIGH TEMPERATURE HAZARDS**  
This product maintains molten plastic at high pressure. Use caution when operating and servicing the system. Physical contact with molten plastic may result in severe burns. Proper protective equipment, including eye protection, must be worn. This product has heated surfaces. Use caution when operating and servicing the system to avoid severe burns. Proper protective equipment should be worn.

#### WIRING INFORMATION

Square Coil Heaters are supplied with 2" prestripped 36" long leads. Heaters are 240 VAC.  
2 power leads are Multi Color.  
1 ground lead is GREEN.  
Thermocouple is "J" Type.  
Thermocouple is supplied with 36" leads.  
1 T/C lead is WHITE and negative (-)  
constantan (non-magnetic).  
1 T/C lead is BLACK and positive (+)  
iron (magnetic).

### D-M-E COMPANY

29111 STEPHENSON HIGHWAY  
MADISON HEIGHTS  
MICHIGAN 48071 USA  
US 800-656-6653  
CANADA 800-387-6600  
www.dme.net