

ME-0741-PS-778-B 08-08 SCH9999

FRONT LOAD SQUARE COIL HEATER INSTALLATION DATA

Please read carefully before
installing and/or removing heater.

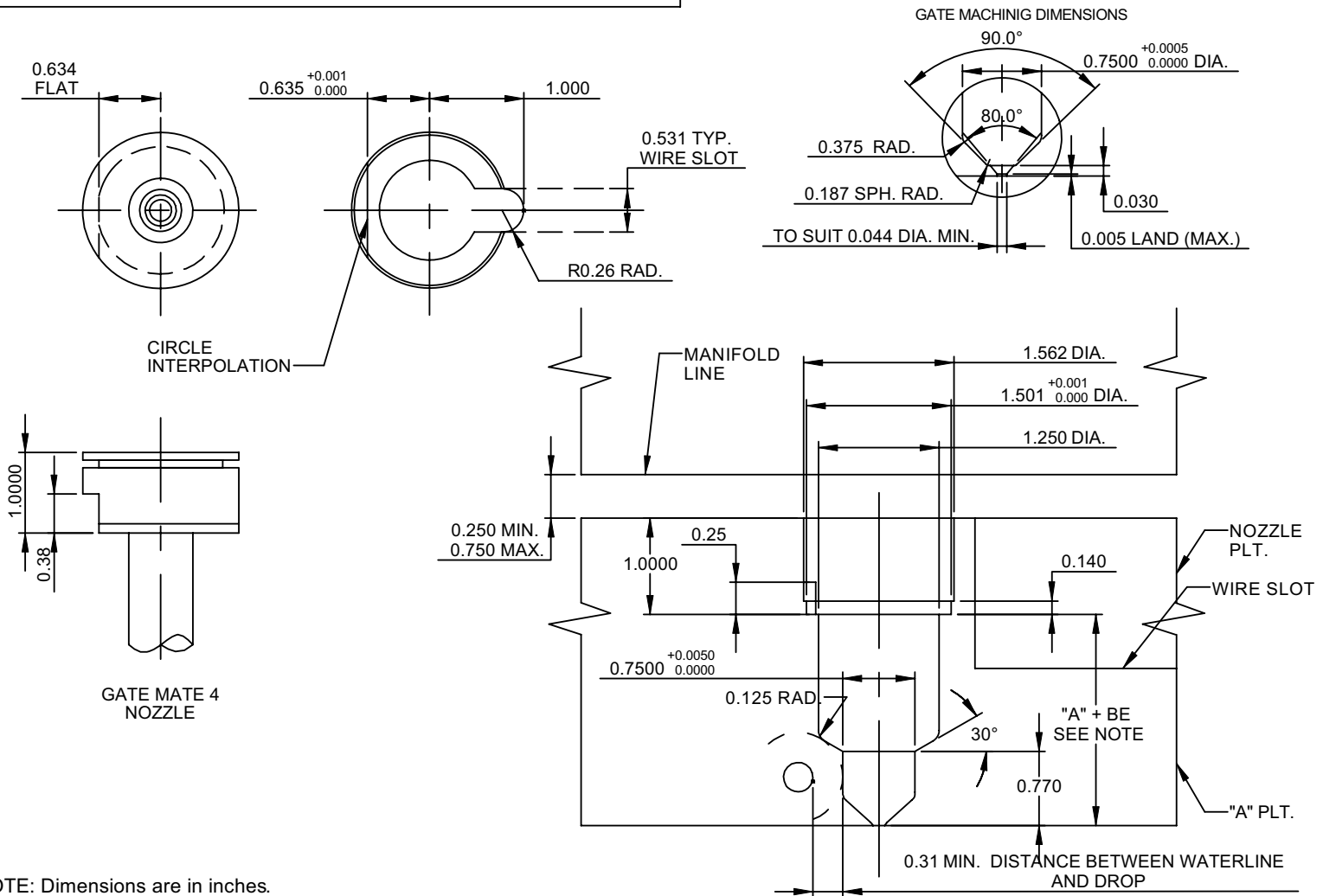

NOTE: Dimensions are in inches.

NOTE: The expansion factor must be taken into consideration prior to machining and installing nozzle. This factor (BE) must then be added to the nominal "A" dimension. Formula for determining this expansion factor is as follows:
 $BE = "A" \text{ dimension} \times 0.00000633 \times (\text{Nozzle set point temperature} - 68^{\circ}\text{F})$

EXAMPLE: Given a 2.5 inch "A" dimension, with a nozzle set point temperature of 500°F:
 $BE = 2.5 \times 0.00000633 \times (500 - 68) = 0.0068 \dots$ thus "A" + BE will be 2.5068.

Please note that the above information is only given as an example. variations may occur based on mold configurations and cooling factor. In some instances, it may be necessary to obtain an empirical factor.

CATALOG NUMBER	SUB-ASSY. NUMBER	"B" DIM.	"L" DIM.	WATTAGE	NOZZLE REF. NO.
SCH1060	GMB1050	0.875	1.594	250	GMB0060
SCH1061	GMB1051	0.875	2.094	300	GMB0061
SCH2061	GMB2051	1.375			
SCH1062	GMB1052	0.875	2.594	350	GMB0062
SCH2062	GMB2052	1.375			
SCH1063	GMB1053	0.875	3.094	400	GMB0063
SCH2063	GMB2053	1.375			
SCH1064	GMB1054	0.875	3.594	425	GMB0064
SCH2064	GMB2054	1.375			
SCH1065	GMB1055	0.875	4.594	500	GMB0065
SCH2065	GMB2055	1.375			
SCH1066	GMB1056	0.875	5.594	500	GMB0066
SCH2066	GMB2056	1.375			

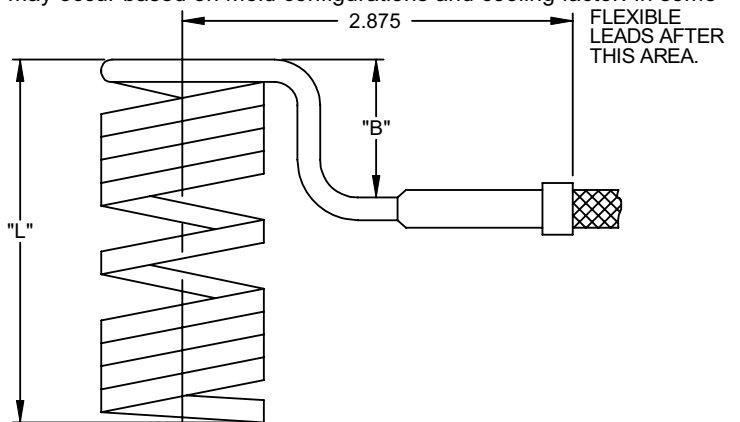

D-M-E SHALL NOT BE LIABLE FOR MISUSE OR FAILURE TO FOLLOW THE ENCLOSED INSTRUCTIONS AND SPECIFICATIONS. D-M-E HERBY TO DISCLAIMS ALL IMPLIED WARRANTIES, INCLUDING MERCHANTABILITY AND FITNESS FOR A PARTICULAR PURPOSE. IN NO EVENT SHALL D-M-E BE RESPONSIBLE FOR LOSS OF USE, REVENUE OR PROFIT, OR FOR INCIDENTAL OR CONSEQUENTIAL DAMAGED.

ME-0741-PS-778-B 08-08 SCH9999
FRONT LOAD SQUARE COIL HEATER
INSTALLATION DATA
 Please read carefully before
 installing and/or removing heater.



RECOMMENDATIONS AND GUIDELINES

1. Front Load Square Coil Heaters are designed to be used with Gate Mate 4 Nozzles only.
2. The nozzle head must be held in such a manner to keep it from rotating upon installation of the front load square coil heater. This may be done by making a key for the head to match the flat on the nozzle's head or by circle interpolation.
3. Nozzle plate must be designed so that the heads of the socket head cap screws are exposed when the mold is split on the parting line.
4. After the nozzle has been located and positioned in the nozzle plate with manifold secured in place and "A" plate removed. The heater can be installed on the nozzle body as follows:
 - a. Place heater within Tube "A" so that the bending exit lead lies within the slot of the tube.
 - b. Insert tube "B" with angle cut within Tube "A" so that the angle of the Tube mates with the last coil of the heater.
 - c. Rotate Tube "A" counterclockwise while at the same time rotating tube "B" clockwise. This action will spring open the coils enough to slide the heater onto the shaft of the nozzle body.
 - d. Slide the heater onto the nozzle body shaft aligning the heater exit lead within the relief slot in the nozzle's head.
 - e. Position heater so that the end of the last coil is above the relief of the seal-off area. (see figure above).
5. The power and thermocouple leads may be spliced in the wiring channel for ease of heater replacement.

* Leads may be spliced using Thomas & Betts nylon insulated disconnects.
 Male Cat. No. 18RA-251T
 Female Cat. No. 18RA-2577
6. Secure wires in wire channel with straps before assembling "A" plate to mold.

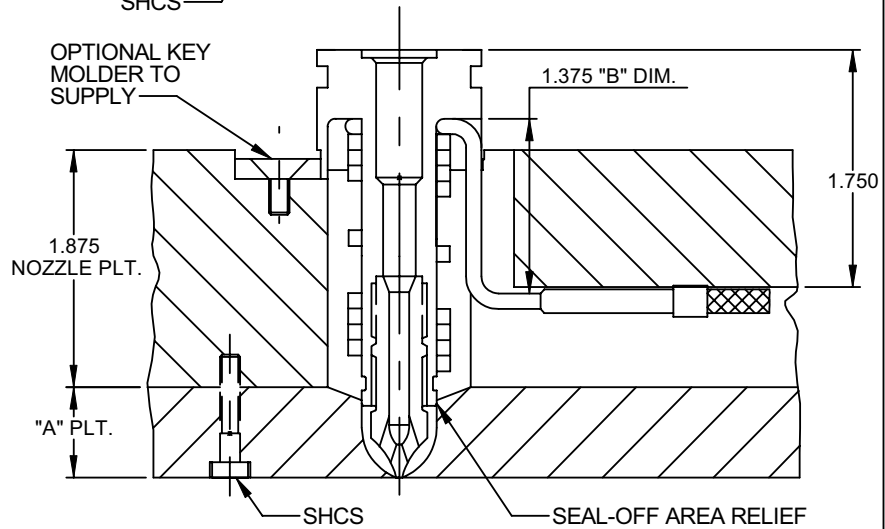
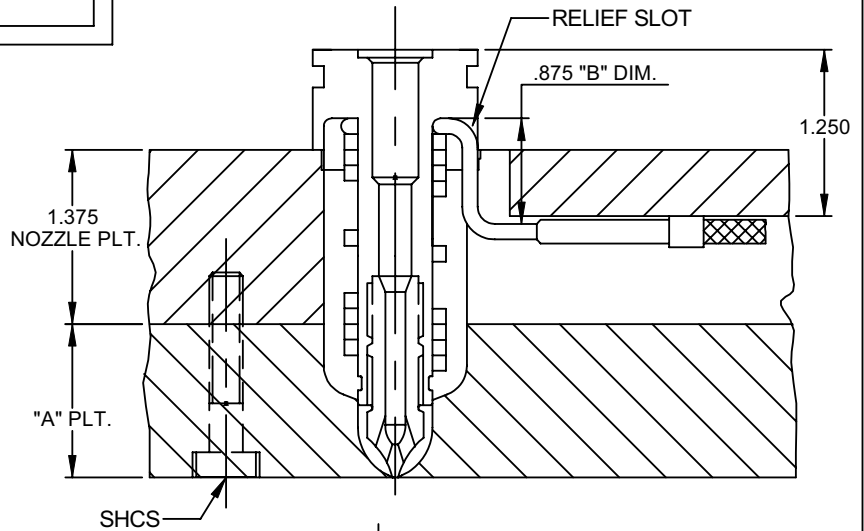

OPERATING PROCEDURE

The nozzles are supplied with a Square (Flat) Coil Heater. It is recommended to use a D-M-E closed loop Temperature Controller for optimum Temperature Control. When starting the nozzle, set the temperature to 10% voltage if using in open loop manual type or to 200°F if using closed loop automatic type. In either case this procedure will allow the heater to dissipate any moisture. Make sure you maintain this start-up setting for 15 minutes. Controller equipped with Step Smart ®, Smart Step ® or other heater warm-up circuitry will change automatically. It is essential to use controllers with the proper voltage and wattage capabilities. The voltage and wattage of each heater is clearly marked on the heater tag.

Step Smart ®, Smart Start ® and DME ® are all registered trademarks of DME Company.

WIRING INFORMATION

Square Coil Heaters are supplied with 2" prestripped 36" long leads. Heaters are 240 VAC. (120 VAC heaters are available on request).
 2 power leads are Multi Color.
 1 ground lead is GREEN.
 Thermocouple is "J" Type.
 Thermocouple is supplied with 36" leads.
 1 T/C lead is WHITE and negative (-) constantan (non-magnetic).
 1 T/C lead is BLACK and positive (+) iron (magnetic).

IMPORTANT SAFETY INFORMATION

A hot-runner system includes electrical elements and may contain molten plastic at elevated temperature and pressure. To avoid injury, exercise caution by reading these instructions before servicing or operating the system.

These instructions must be passed on to the end user where they should be read before using this product. Failure to do so can result in serious injury or death.



Failure to comply will result in serious injury or death:

ELECTRICAL HAZARDS

Improper voltages or grounding can result in electrical shock. Use only with proper voltage and a proper earth ground.
 To avoid electrical shock, do not operate product when wet.
 Do not operate this equipment with covers or panels removed.
 To avoid electrical shock, turn off main power disconnect and lockout / tag out before servicing this device. Do not connect temperature sensors to electrical power. It will damage the product and it can cause fire, severe injuries or even death.
 If green ground wire present wire must be connected to the ground.
 Do not rebend rigid leads. Rebending leads might result in damage to circuit.
 Product might absorb moisture when cool. Use low Voltage or power to drive out residual moisture before applying full power. Failure to do so may cause damage to this product.



Failure to comply can result in serious injury or death:

STORED ENERGY AND HIGH TEMPERATURE HAZARDS

This product maintains molten plastic at high pressure. Use caution when operating and servicing the system.
 Physical contact with molten plastic may result in severe burns. Proper protective equipment, including eye protection, must be worn. This product has heated surfaces. Use caution when operating and servicing the system to avoid severe burns. Proper protective equipment should be worn.

D-M-E COMPANY

29111 STEPHENSON HIGHWAY
 MADISON HEIGHTS
 MICHIGAN 48071 USA
 US 800-656-6653
 CANADA 800-387-6600
 www.dme.net