

Mold Curtains

Mold side curtains provide an effective means of confining molded parts on multi-cavity molds that have a tendency to fly out, thus reducing the risk of contamination, loss or damage.

- Sizes not shown custom made to your dimensions.
- Velcro fitting permits easy access to mold cavities.
- Clear vinyl aids visibility to mold.

Complete unit includes:

- (2) 1½" x 1½" aluminum angle mounting brackets attached with bolts to mold and velcro to curtain.
- (1) ¼" steel alignment rod to prevent curtain from collapsing into mold.

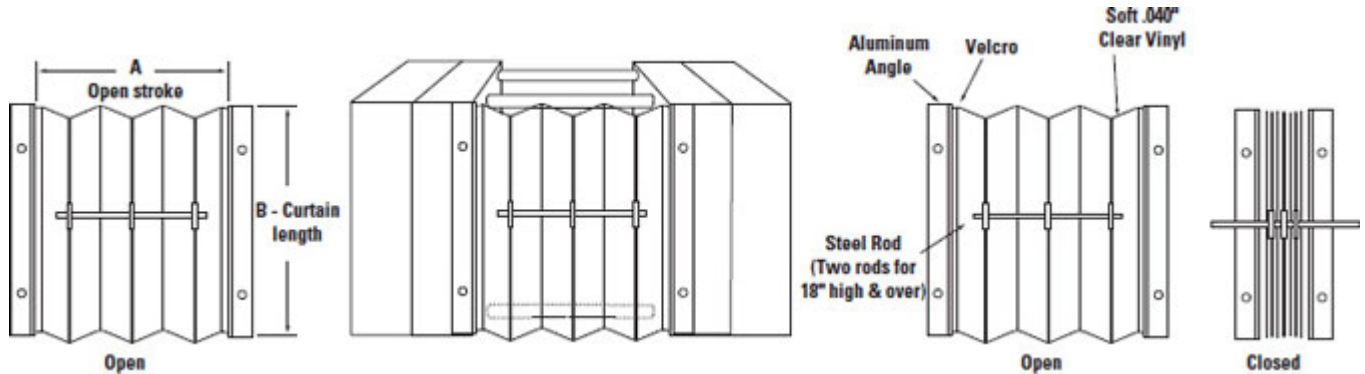

Width A	Length B	Part No.
4"	12"	SC01
6"	15"	SC02
8"	18"	SC03
10"	21"	SC04
12"	24"	SC05
14"	27"	SC06
16"	30"	SC07
18"	33"	SC08
20"	36"	SC09

Note: Side curtains require 3" gap between mold and tie bar. The curtain can only be as long as the tie bar spacing if adequate space does not exist.

Alternate vertical panels are clear vinyl to provide visibility to the mold. Aluminum angle mounting brackets are designed to attach directly to the mold, not to the platen.

Ensure adequate clearance between waterline fittings on the parting line, to allow the curtain to collapse in between when the mold is closed. Curtain open stroke and curtain length should not exceed 30".

- A: Mold open _____
- E: Width of opening _____
- C: Height of opening _____
- D: Length of opening _____
- F: Floor to opening _____
- I: End to opening _____
- L: Height of end opening _____
- H: Width of opening _____

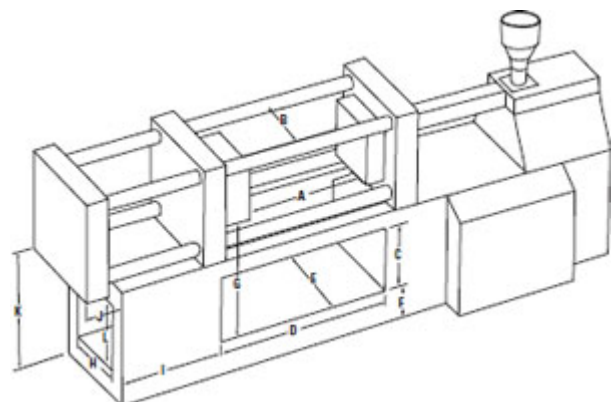

Company: _____
 Contact: _____
 Address: _____
 City: _____ State: _____
 Zip: _____
 Country: _____

Account Number: _____
 PO #: _____ Job #: _____
 Phone: _____
 Fax #: _____
 E-mail: _____

SUBMIT