

# Screen Pack Metal Filter

**Tramp Metal Filter For all makes and models of injection molding machines.**

Screens out harmful material that may clog orifice of hot runner molds.

2" diameter filter disc has 135 holes for maximum removal of contaminants and minimum drop in pressure. Use in place of your regular nozzle. We have the size for your machine.

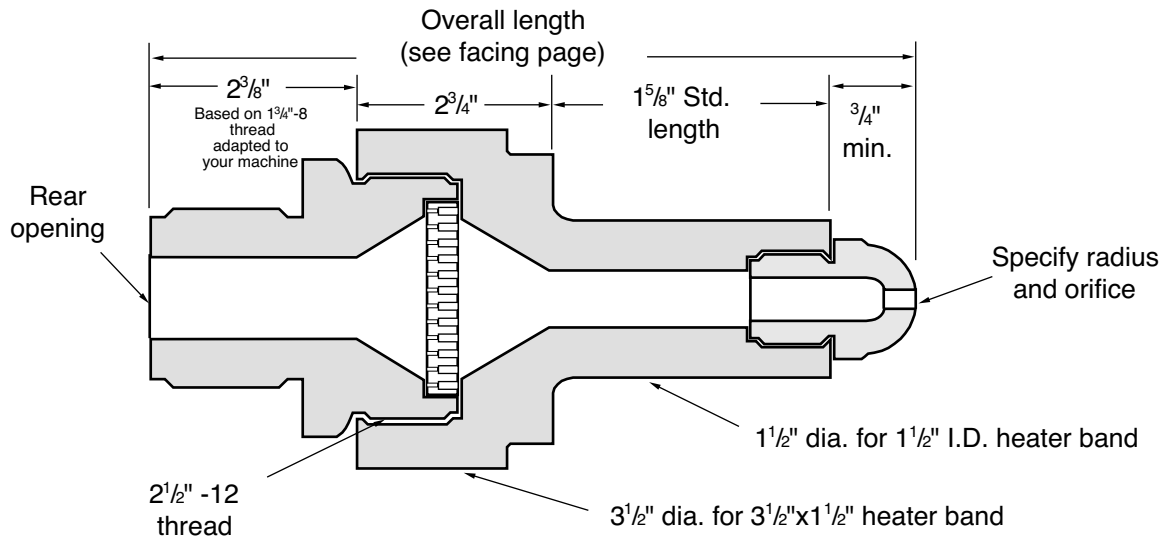

Complete assembly includes threaded end mount, 2" dia x 3/8" filter disc, removable nozzle and hardened tool steel removable nozzle tip to suit your application.

Assembly MTN1 or MTN2 consists of:  
 MTN1A.....Adapter to suit machine  
 MTN1.....Nozzle  
 SPFD1.....Filter  
 RT1, 2, 3 or 4.....Tip

Machines with Thread Size of 50mm(2") or less			Machines with Thread Size OVER 50mm(2")		
Type	Part#	Price	Type	Part#	Price
General Purpose or Nylon	<b>MTN1</b>	\$510	General Purpose or Nylon	<b>MTN2</b>	\$534
ABS Full Taper	<b>MTN1C</b>	\$522	ABS Full Taper	<b>MTN2C</b>	\$546

**Ordering: Specify thread size, radius, orifice, make & model of machine.**

For thermocouple hole ~Specify thread  
 (add \$9.60 to price to the left).

**For all makes and models of injection molding machines.**  
 Ordering information for Screen Pack Filters & Adapters.



New design nozzle filter for tramp metal-provides all the benefits of huge filtering capacity and from stock shipment, to get you running without delay. Uses standard Adaptors with thread to suit your machine, standard "VR" nozzles, with 1 3/4" thread and regular replacement tips.



**TMF40 Filter Disk**

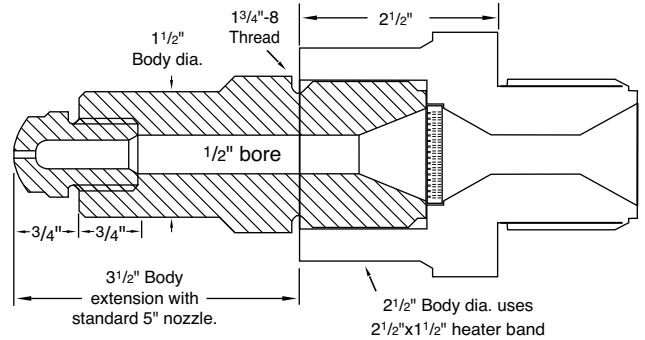

3/8" TMF40 filter disk

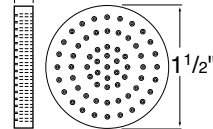

63 holes  
 Major diameter .093"  
 Minor diameter .035"

Item	Part No.	Price
Adapter	<b>TMPA</b>	\$210
Filter	<b>TMF40</b>	\$83
5" Nozzle (including Tip)	<b>VR5A</b>	\$78

If your nozzle thread specification is not shown on the following pages, please complete the dimensional data shown above and fax back to us.

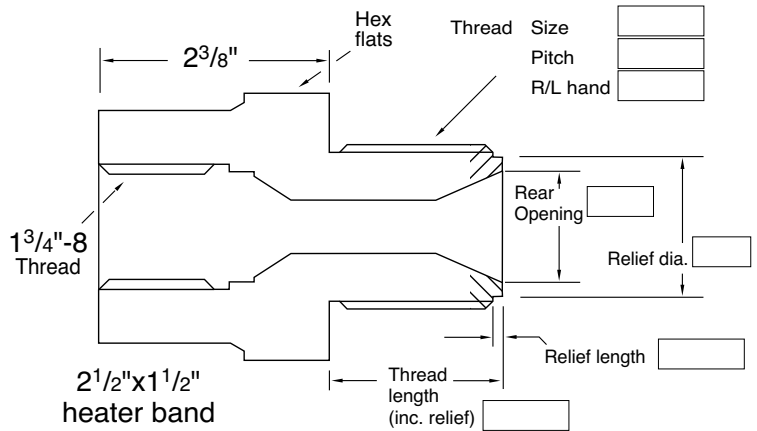

Simply send us the information requested in the 7 boxes above and other details below...

- (a) Radius (flat, 1/2", 3/4", etc.)..... \_\_\_\_\_
- (b) Orifice (from table)..... \_\_\_\_\_
- (b) Internal Design  
 (general purpose, nylon reverse taper or ABS full taper)..... \_\_\_\_\_

Machine Make \_\_\_\_\_ Model \_\_\_\_\_ Year \_\_\_\_\_

Your name \_\_\_\_\_ Company \_\_\_\_\_ Tel: \_\_\_\_\_

Address \_\_\_\_\_

# Metal Filter

**Simple behind-the-tip filter.  
Fitted in minutes**

Low cost effective device to aid in color dispersion with minimum pressure drop. Disk is located in front portion of nozzle, directly behind nozzle tip or in front portion of nozzle (requires recess in tip or nozzle). Removes fish eyes and unplastitized particles. Also provides general dispersion.

## Dispersion Disk Filter

### Nozzle Recess



**FD001 49x0.025" holes**  
**FD002 37x0.031" holes**  
**FD003 7x0.093" holes**



**DD1 9x.045" holes**

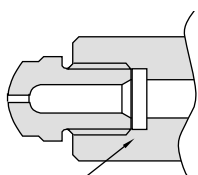

Filter Disk DD1 recessed into nozzle

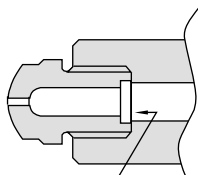

Filter Disk FD001-3 recessed into tip

### DD1 nozzle recess filter

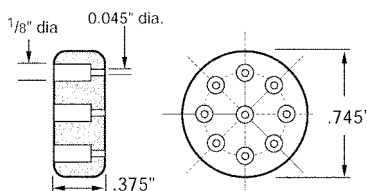

### FD001, FD002 & FD 003 Nozzle tip recess filter

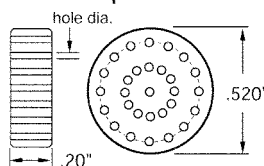

holes:	no	dia
FD001	49	.025"
FD002	37	.031"
FD003	7	.093"

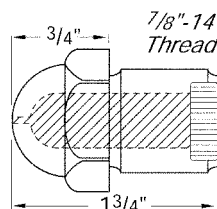

FD-type filter disk in machined recess in rear of regular tip

### Recess tips:

**General Purpose**

**RTR1 \$31.20**

**Nylon Taper**

**NTR1 \$31.20**

**ABS**

**ABR1 \$31.20**

Type	# of holes	Diameter of ea. hole	Total area of holes	Equiv. Orifice	Part#	Price Ea.	
						1-3	4+
Nozzle Recess	9	.045"	.0143 sq. in.	0.135"	<b>DD1</b>	\$42	\$40
Tip Recess	49	.025"	.024 sq. in.	0.175"	<b>FD001</b>	\$54	\$50
Tip Recess	37	.031"	.028 sq. in.	0.189"	<b>FD002</b>	\$50	\$48
Tip Recess	7	.093"	.048 sq. in.	0.250"	<b>FD003</b>	\$47	\$43

# Metal Filter Adaptor



- Use Standard 1 3/4 - 8 Van Dorn Style Nozzle
- Filter Pack made from 507 steel and hardened to 60 rockwell
- Filters foreign matter & mixes color
- Split design for easy cleaning
- Large filter capacity
- Specify thread size & make of press

**Adaptor**     \$222.00  
**Filter Pack** \$102.00  
**Assembly**    \$324.00

B

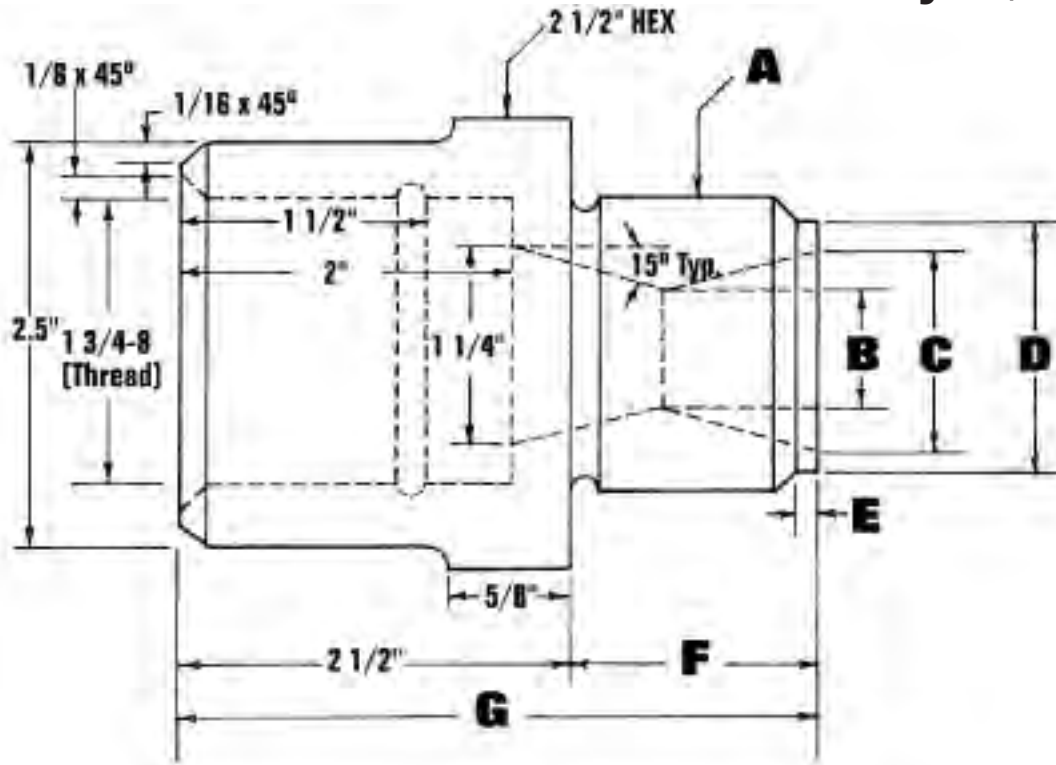

**Your Specs:**  
 please fill out and fax with order

A = \_\_\_\_\_  
 B = \_\_\_\_\_  
 C = \_\_\_\_\_  
 D = \_\_\_\_\_  
 E = \_\_\_\_\_  
 F = \_\_\_\_\_  
 G = \_\_\_\_\_

Company \_\_\_\_\_  
 Name \_\_\_\_\_  
 Address \_\_\_\_\_  
 \_\_\_\_\_  
 Phone Number \_\_\_\_\_  
 Fax Number \_\_\_\_\_

featuring the best of:

# Dispersion Discs

Dispersion Disc to fit behind a **STANDARD NOZZLE TIP**

You asked for it, We found it! Now you can purchase a dispersion disc to fit behind your standard 7/8 - 14 Replaceable Nozzle Tips!

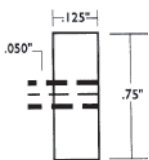
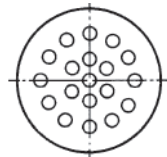

No leakage, seals tight  
More convenient  
Improves color mixing  
More effective for removing impurities  
Made in the U.S.A.

Part Number	Dia. Hole	Price Ea.	
		1-10	11+
<b>D34-050</b>	0.050"	\$16.20	\$15.60
<b>D34-025</b>	0.025"	\$18.00	\$17.40

**NOTE: ALL PRICES ARE IN CANADIAN DOLLARS!**

## 9/16 Diameter Dispersion Discs

### General Purpose Tip

Part No. RTGD  
**\$34.80**  
Nozzle Counter Bored for Dispersion Disc.

Order discs installed in a general purpose tip or separately. Available with either .025, .050 or .085 diameter holes. These tips provide quick access, improved color mixing and prevents foreign material passage.

### .085 Dispersion Disc

Part No. D085  
**\$14.40**  
Complete assembly ( Nozzle & Disc)  
RTGD085 \$49.20

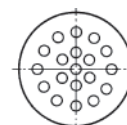

### .050 Dispersion Disc

Part No. D050  
**\$12.00**  
Complete assembly ( Nozzle & Disc)  
RTGD050 \$46.80

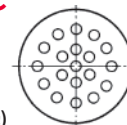

### .025 Dispersion Disc

Part No. D025  
**\$18.00**  
Complete assembly ( Nozzle & Disc)  
RTGD025 \$52.80

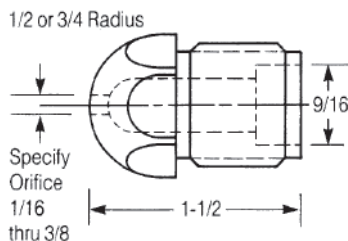
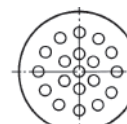

**NOTE: ALL PRICES ARE IN CANADIAN DOLLARS!**

## Shutoff Nozzle Tip

Minimize nozzle drool and sink patterns  
Installs instantly in all 7/8-14 nozzle bodies (Body not included)  
The spring loaded valve in the nozzle tip restricts movement of material until activated by pressure.  
Opens in the direction of the sprue bushing and closes until recycled

Part Number	Radius	Orifice	Min. Sprue Bushing	Price Each
<b>SHUTOFF12-116</b>	1/2"	1/16"	7/32"	<b>\$99.60</b>
<b>SHUTOFF12-18</b>		1/8"	9/32"	
<b>SHUTOFF12-316</b>		3/16"	5/16"	
<b>SHUTOFF34-116</b>	3/4"	1/16"	7/32"	
<b>SHUTOFF34-18</b>		1/8"	9/32"	
<b>SHUTOFF34-316</b>		3/16"	5/16"	

Assembled

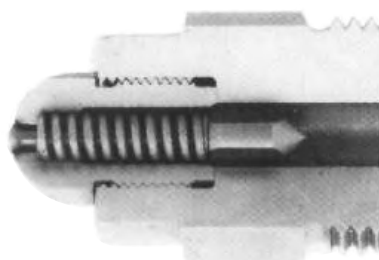

Radius: 1/2 or 3/4 Orifice 1/16, 1/8, 3/16

**NOTE: ALL PRICES ARE IN CANADIAN DOLLARS!**