

Resin Handling Bins

Ideal for Storage and Transfer of Material

From Grinders, Surge Bins, Bags, Drums or Gaylords

Resin Bins Features:

- Mobile
- Self-Emptying
- Durable
One piece reinforced lid suitable for mounting equipment
- Lightweight
*Easily view contents
Polyethylene construction*
- Stackable
RB90L, RB175L and RB400L Only
- Stainless Steel Slidegate
- Vacuum Wand Access Tube
*4" Diameter opening
(exception: RB90L has a 2.75" Dia. Opening)*
- Heavy-Duty Welded Steel Frame
- Forklift Channel
RB1200L and RB1200LC
- Locking Casters
Standard and included with RB90L, RB175L and RB400L



	Stackable			Non-Stackable			
Part Number	RB90L	RB175L	RB400L	RB800L	RB800LC	RB1200L	RB1200LC
Capacity	81lbs	158lbs	368lbs	800lbs	800lbs	1200lbs	1200lbs
Volume	2.3 CF	4.5 CF	10.5 CF	22.7 CF	22.7 CF	34.2 CF	34.2 CF
Size (L x W x H)	18" x 18" x 30.1"	23" x 23" x 37.6"	31" x 31" x 42.8"	37.5" x 37.5" x 52.4"	37.5" x 37.5" x 52.4"	43.5" x 43.5" x 54.7"	43.5" x 43.5" x 54.7"
Casters	(4) 4" Toe-Locking, Full Swivel Casters INCLUDED!			NONE	(4)5" Casters: (2) fixed+ (2) Swivel & Toe Locking	NONE	(4)5" Casters: (2) fixed+ (2) Swivel & Toe Locking
Holds	1+ Bags	3+ Bags	1+ Drum	2+ Drums	2+ Drums	1+ Gaylord	1+ Gaylord
Price							
1-9	\$230.00	\$320.00	\$425.00	\$685.00	\$765.00	\$740.00	\$840.00
10+	\$211.60	\$294.00	\$391.00	\$630.00	\$704.00	\$680.00	\$773.00

Tilters, Dumpers, Mixers & Bins



On the following pages are listed the finest tilters, mixers, dumpers and storage bins in the industry today. Don't fall for cheap imitations. Our equipment is constructed of high-grade steel and covered with a durable epoxy blue coating. The overall design stems from many years in the manufacturing field, with constant refinements along the way to incorporate the changing needs of the industry.

We steadfastly stand behind every one of our equipment with one of the most comprehensive warranties in the industry—a **FULL TWO YEAR WARRANTY**. We can also customize any of these items to suit whatever application you need.



Warranty

These products carry a **full two year warranty** covering defects in materials, manufacture and workmanship. Also, all STANDARD products are covered by a 30-day trial period guaranteeing customer satisfaction!

DME Molding Supplies features the best of:

Northern Supply (800-365-6565) • Nickerson Machinery (800-821-9534) • OHS (Ontario-888-809-7050/Quebec-888-475-9224)

Portable Storage Bins

The **Portable Storage Bin** is an inexpensive, versatile shop performer. Strongly built with full 14 gauge sidewalls and ¼" thick legs, these bins are constructed to withstand the abuse of a busy shop! Special flared pads help make stacking (up to three high!) simpler and safer. Durable abrasion-resistant epoxy painted blue inside and out. Units may be ordered with or without covers or vacuum entry ports for maximum economy tailored to your needs. The 4" discharge features an adjustable tension slide gate. Four way fork channels, pallet jack rails, casters, and product view windows are some of the available options. Standard 44 inch square design in capacities of 20, 30, 40, 50, or 60 cubic feet, or can be custom designed to fit your particular requirements! Watch these bins save your operation both time and space!



Options

- Pallet Jack Channels
- 4" Casters (2 rigid, 2 swivel)
- 4-way Fork Entry
- Foot Pads
- 3" x 5" Card Holders
- Vacuum Port Covers (set)

Other options available - or will custom design to fit your needs!

Warranty

These products carry a **full two year warranty** covering defects in materials, manufacture and workmanship. Also, all STANDARD products are covered by a 30-day trial period guaranteeing customer satisfaction!

Portable Storage Bins

Part Number	Description	Price
40-2000	PSB-20 cu. ft. base unit	\$695.00
40-2100	PSB-20 cu. ft. with four way vacuum ports	\$755.00
40-2010	PSB-20 cu. ft. with 2-piece cont. hinged covers	\$830.00
40-2110	PSB-20 cu. ft. With vacuum ports AND covers	\$890.00
40-3000	PSB-30 cu. ft. base unit	\$735.00
40-3100	PSB-30 cu. ft. with four way vacuum ports	\$795.00
40-3010	PSB-30 cu. ft. With 2-piece cont. hinged covers	\$870.00
40-3110	PSB-30 cu. ft. With vacuum ports AND covers	\$930.00
40-4000	PSB-40 cu. ft. base unit	\$880.00
40-4100	PSB-40 cu. ft. with four way vacuum ports	\$940.00
40-4010	PSB-40 cu. ft. with 2-piece cont. hinged covers	\$1,015.00
40-4110	PSB-40 cu. ft. with vacuum ports AND covers	\$1,075.00
40-5000	PSB-50 cu. ft. base unit	\$1,050.00
40-5100	PSB-50 cu. ft. with four way vacuum ports	\$1,110.00
40-5010	PSB-50 cu. ft. with 2-piece cont. hinged covers	\$1,185.00
40-5110	PSB-50 cu. ft. with vacuum ports AND covers	\$1,245.00
40-6000	PSB-60 cu. ft. base unit	\$1,165.00
40-6100	PSB-60 cu. ft. with four way vacuum Ports	\$1,225.00
40-6010	PSB-60 cu. ft. with 2-piece cont. hinged covers	\$1,300.00
40-6110	PSB-60 cu. ft. with vacuum ports AND covers	\$1,360.00

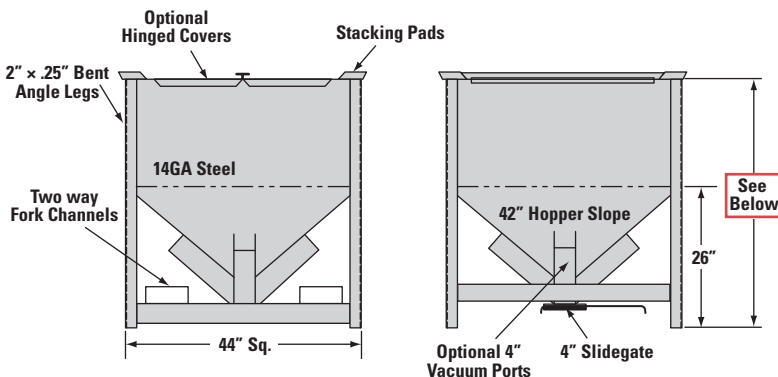

Overall Height (w/vacuum ports)	Overall Height (w/OUT vacuum ports)	Capacity (cu.ft.)
36"	32"	20
46"	42"	30
56"	52"	40
66"	62"	50
76"	72"	60