

ME-06-0005-0008(D) 11-2010 Catalog #: BGTIP  
 INSTALLATION DATA  
 FOR BLACK & GOLD TOP INTERCHANGEABLE INTERLOCKS  
 Please read carefully before installing components.

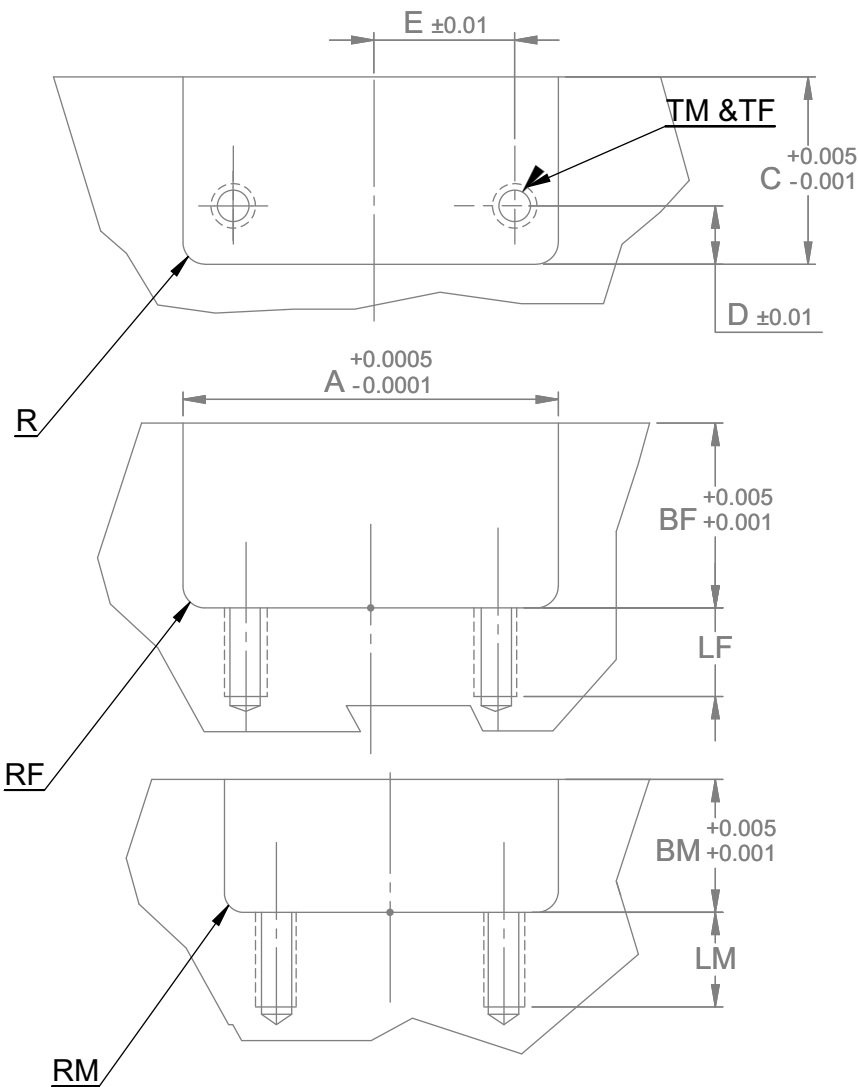
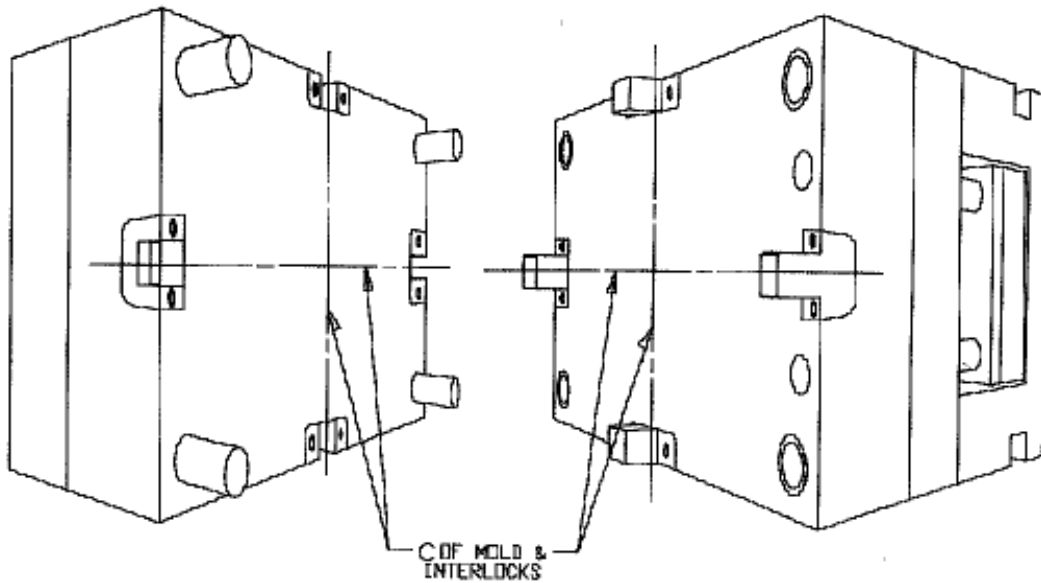

Dimensions Shown in Inches  
 Unless otherwise specified,  
 Tolerances are:

Fractions	+/- 0.015
0.00	+/- 0.01
0.000	+/- 0.005

RECOMMENDED POCKET  
 SURFACE FINISH IS 63 Ra

ME-06-0005-0008(D) 11-2010 Catalog #: BGTIP  
 INSTALLATION DATA  
 FOR BLACK & GOLD TOP INTERCHANGEABLE INTERLOCKS  
 Please read carefully before installing components.



**Installation Instructions:**

1. Four D-M-E Top Interlocks must be used in each mold application. When in operation, the interlocks contact the edges of the machined pocket to maintain parting line alignment. The cap screws are only utilized to retain the interlocks to the mold base.
2. To maintain alignment, it is recommended that the mold base assembly be clamped together and machined in assembly to insure proper parting line alignment.
3. Machine the interlock pockets accurately in assembly. Locate each interlock pocket on the centerline of the mold. The location is critical to avoid misalignment problems which could result from uneven thermal expansion of the separate mold halves.
4. Mount the female interlock on the half of which will have the highest operating temperature. Normally, this will be the "A" side of the mold. This procedure is critical to insure that the male interlock does not grow larger than the female interlock if uneven mold temperatures are present.
5. Torque the mounting SHCS to:
  - 30 in.lbs for #6-32 SHCS
  - 55 in.lbs for #8-32 SHCS
  - 90 in.lbs for #10-32 SHCS
  - 200 in.lbs for 1/4-20 SHCS
  - 415 in.lbs for 5/16-18 SHCS
  - 740 in.lbs for 3/8-16 SHCS
6. After installation, open and close the mold on the bench to insure proper alignment.

CAT #	CAT #	A	BM	BF	C	RF/RM	R	D	E	TM	TF	LM	LF
MALE	FEMALE		MALE	FEMALE						MALE	FEMALE	MALE	FEMALE
		POCKET WIDE	POCKET WIDTH	POCKET WIDTH	POCKET DEPTH	POCKET RADIUS	POCKET RADIUS	SCREWS LOCATIONS		SHCS SIZE	SHCS SIZE	THREAD LENGTH	
BGT1250M	BGT1250F	1.250	0.500	0.625	0.625	0.125	0.016	0.312	0.438	#6-32 x 5/8"	#6-32 x 3/4"	0.312	0.312
BGT1500M	BGT1500F	1.500	0.750	0.875	0.875	0.125	0.016	0.437	0.500	#8-32 x 7/8"	#8-32 x 1"	0.375	0.375
BGT2000M	BGT2000F	2.000	0.750	1.125	1.000	0.250	0.016	0.500	0.688	#10-32 x 1"	#10-32 x 1 1/4"	0.625	0.500
BGT3000M	BGT3000F	3.000	0.750	1.500	1.125	0.375	0.016	0.562	1.125	1/4-20 x 1"	1/4-20 x 1 3/4"	0.750	0.750
BGT3000SM	BGT3000SF	3.000	0.875	1.250	1.750	0.375	0.016	0.875	1.125	5/16-18 x 1 1/8"	5/16-18 x 1 5/8"	0.750	0.875
BGT3500M	BGT3500F	3.500	0.750	1.750	2.000	0.375	0.016	1.000	1.250	3/8-16 x 1"	3/8-16 x 2"	0.750	0.750

Dimensions Shown in Inches  
 Unless otherwise specified,  
 Tolerances are:  
 Fractions +/- 0.015  
 0.00 +/- 0.01  
 0.000 +/- 0.005



29111 STEPHENSON HIGHWAY  
 MADISON HEIGHTS  
 MICHIGAN 48071 USA  
 US 800-656-6656  
 CANADA 800-387-6600  
 www.dme.net