

P.E.T.S.® Valve Gate Hot Runner Solutions From DME

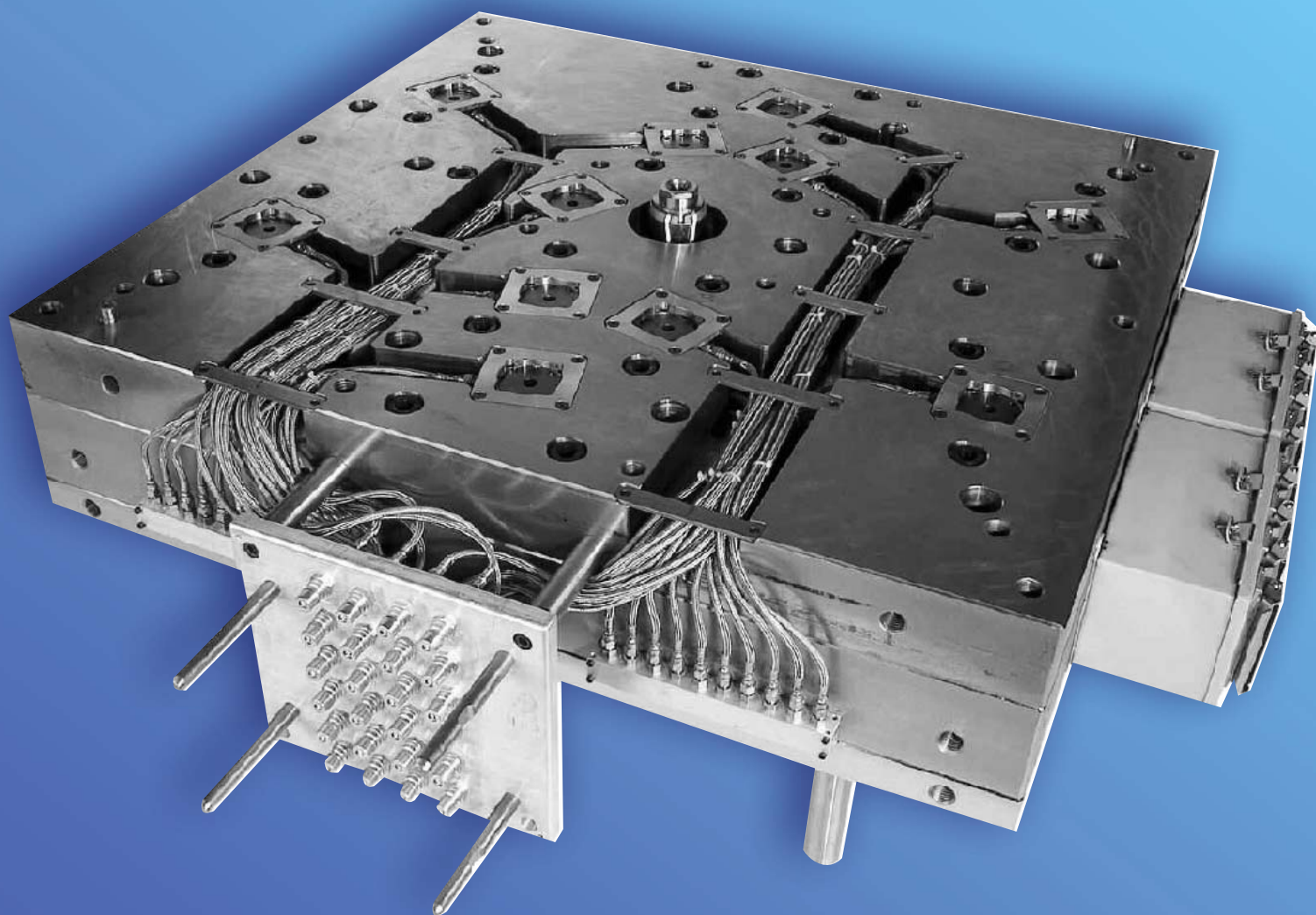

**Valve gate system solutions
for every market**



DME P.E.T.S. Valve Gate Hot Runner Solutions

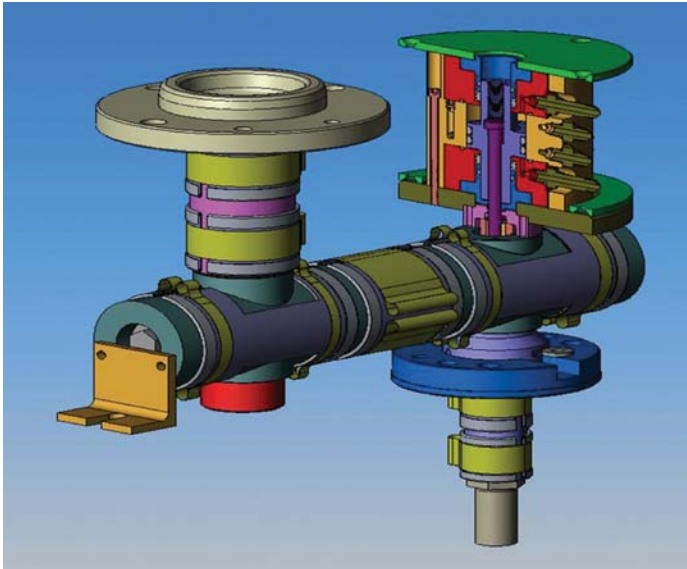

System Features:

- Low shear melt channels for improved processing and part quality
- Hydraulic, pneumatic or electric pin actuation options
- Round or rectangular manifold construction
- Full "hot half" system or unitized options
- Short cycle times
- No material waste
- Inch and metric nozzle tips available
- Bodies and tips designed to fit your molding application
- Standard, replaceable components

Benefits:

- Dual-seal P-20 radius plug
- Improves engineering precision
- Round or rectangular manifold construction
- Heavy gauge cover plates
- Multiple zoning
- Internal water-cooled cylinders
- Pre-wired

Results:

- Eliminates "dead spots" that can trap and degrade material
- Achieves precise drop placement
- Retains reliability
- Solution meets your application needs
- Improves heat transfer
- Increases heat control
- Better part quality
- Reduces cycle time

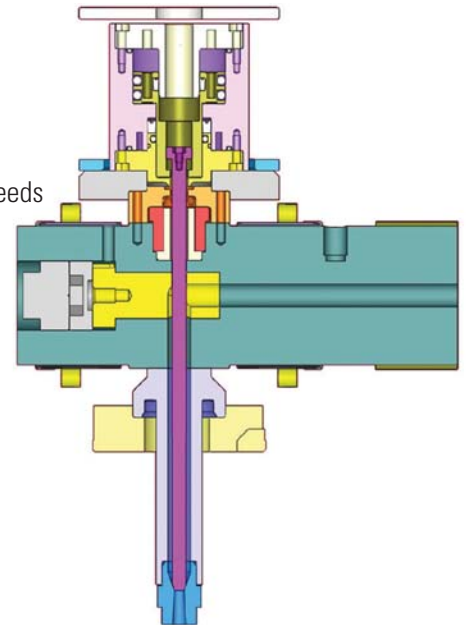

For Valve Gate Hot Runner System quote inquiries, please call DME and ask to speak to a Hot Runner Representative, or email us at appl_eng@dme.net. For technical inquiries, please email us at hrtech@dme.net.



World Headquarters DME Company LLC

29111 Stephenson Highway
Madison Heights, MI 48071
800-626-6653 toll-free tel
248-398-6000 tel
888-808-4363 toll-free fax
www.dme.net web
sales@dme.net e-mail

DME of Canada Ltd.

6210 Northwest Drive
Mississauga, Ontario
Canada L4V 1J6
800-387-6600 toll-free tel
905-677-6370 tel
800-461-9965 toll-free fax
dme_canada@dme.net e-mail

DME Europe

DME Belgium C.V.B.A.
Industriepark Noord
B-2800 Mechelen
Belgium
32-15-215011 tel
32-15-218235 fax
sales@dmeeu.com e-mail